



DVD PLAYER

DVD-739



SERVICE MANUAL

DVD-739

SERVICE *Manual*



DVD PLAYER

CONTENTS

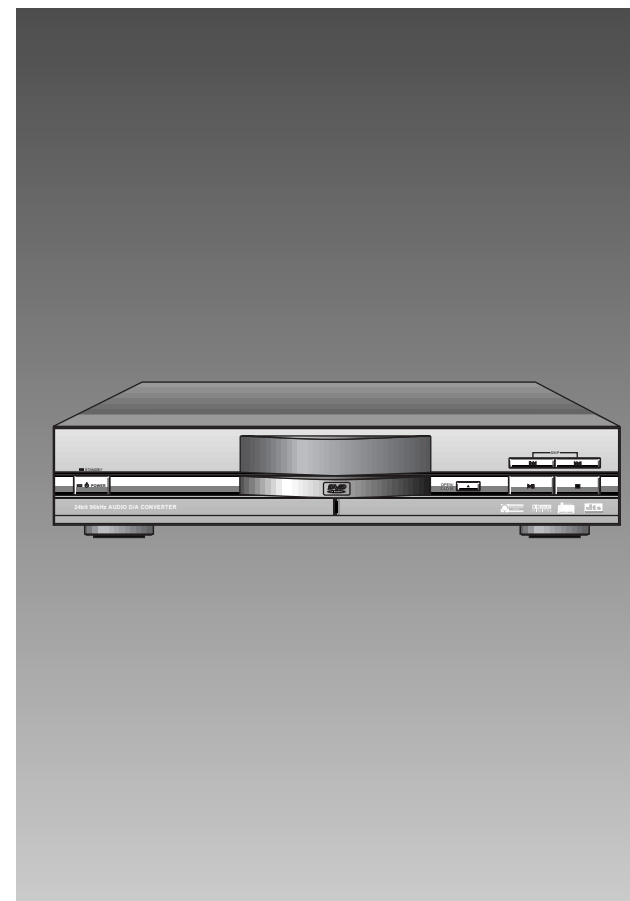

1. Precautions
2. Reference Information
3. Product Specification
4. Operating Instructions
5. Disassembly and Reassembly
6. Circuit Descriptions
7. Troubleshooting
8. Exploded Views and Parts List
9. Electrical Parts List
10. Block Diagram
11. PCB Diagrams
12. Wiring Diagram
13. Schematic Diagrams

1. Precautions

1-1 Safety Precautions

1) Before returning an instrument to the customer, always make a safety check of the entire instrument, including, but not limited to, the following items:

(1) Be sure that no built-in protective devices are defective or have been defeated during servicing. (1) Protective shields are provided to protect both the technician and the customer. Correctly replace all missing protective shields, including any remove for servicing convenience.

(2) When reinstalling the chassis and/or other assembly in the cabinet, be sure to put back in place all protective devices, including, but not limited to, nonmetallic control knobs, insulating fish papers, adjustment and compartment covers/shields, and isolation resistor/capacitor networks. Do not operate this instrument or permit it to be operated without all protective devices correctly installed and functioning.

(2) Be sure that there are no cabinet openings through which adults or children might be able to insert their fingers and contact a hazardous voltage. Such openings include, but are not limited to, excessively wide cabinet ventilation slots, and an improperly fitted and/or incorrectly secured cabinet back cover.

(3) Leakage Current Hot Check-With the instrument completely reassembled, plug the AC line cord directly into a 120V AC outlet. (Do not use a isolation transformer during this test.) Use a leakage current tester or a metering system that complies with American National Standards institute (ANSI) C101.1 Leakage Current for Appliances and Underwriters Laboratories (UL) 1270 (40.7). With the instrument's AC switch first in the ON position and then in the OFF position, measure from a known earth ground (metal water pipe, conduit, etc.) to all exposed metal parts of the instrument (antennas, handle brackets, metal cabinets, screw-heads, metallic overlays, control shafts, etc.), especially any exposed metal parts that offer an electrical return path to the chassis.

Any current measured must not exceed 0.5mA. Reverse the instrument power cord plug in the outlet and repeat the test. See Fig. 1-1.

Any measurements not within the limits specified herein indicate a potential shock hazard that must be eliminated before returning the instrument to the customer.

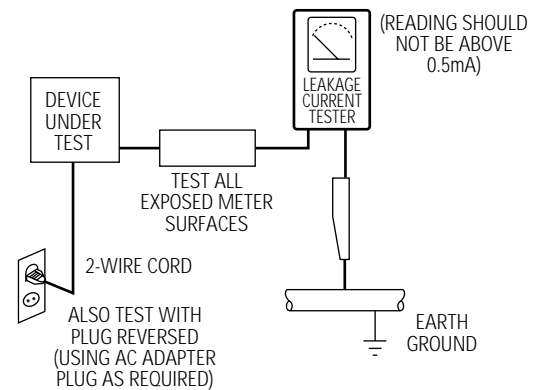

Fig. 1-1 AC Leakage Test

(4) Insulation Resistance Test Cold Check-(1) Unplug the power supply cord and connect a jumper wire between the two prongs of the plug. (2) Turn on the power switch of the instrument. (3) Measure the resistance with an ohmmeter between the jumpered AC plug and all exposed metallic cabinet parts on the instrument, such as screwheads, antenna, control shafts, handle brackets, etc. When an exposed metallic part has a return path to the chassis, the reading should be between 1 and 5.2 megohm. When there is no return path to the chassis, the reading must be infinite. If the reading is not within the limits specified, there is the possibility of a shock hazard, and the instrument must be re-pared and rechecked before it is returned to the customer. See Fig. 1-2.

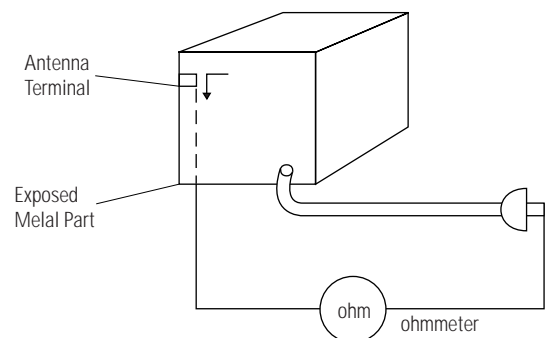



Fig. 1-2 Insulation Resistance Test

- 2) Read and comply with all caution and safety related notes non or inside the cabinet, or on the chassis.
- 3) Design Alteration Warning-Do not alter or add to the mechanical or electrical design of this instrument. Design alterations and additions, including but not limited to, circuit modifications and the addition of items such as auxiliary audio output connections, might alter the safety characteristics of this instrument and create a hazard to the user. Any design alterations or additions will make you, the service, responsible for personal injury or property damage resulting therefrom.
- 4) Observe original lead dress. Take extra care to assure correct lead dress in the following areas:
(1) near sharp edges, (2) near thermally hot parts (be sure that leads and components do not touch thermally hot parts), (3) the AC supply, (4) high voltage, and (5) antenna wiring. Always inspect in all areas for pinched, out-of-place, or frayed wiring. Do not change spacing between a component and the printed-circuit board. Check the AC power cord for damage.
- 5) Components, parts, and/or wiring that appear to have overheated or that are otherwise damaged should be replaced with components, parts and/ or wiring that meet original specifications. Additionally, determine the cause of overheating and/or damage and, if necessary, take corrective action to remove any potential safety hazard.
- 6) Product Safety Notice-Some electrical and mechanical parts have special safety-related characteristics which are often not evident from visual inspection, nor can the protection they give necessarily be obtained by replacing them with components rated for higher voltage, wattage, etc. Parts that have special safety characteristics are identified by shading, an () or a () on schematics and parts lists. Use of a substitute replacement that does not have the same safety characteristics as the recommended replacement part might create shock, fire and/or other hazards. Product safety is under review continuously and new instructions are issued whenever appropriate.

1-2 Servicing Precautions

CAUTION : Before servicing Instruments covered by this service manual and its supplements, read and follow the Safety Precautions section of this manual.

Note : If unforeseen circumstance create conflict between the following servicing precautions and any of the safety precautions, always follow the safety precautions. Remember: Safety First.

1-2-1 General Servicing Precautions

- (1) a. Always unplug the instrument's AC power cord from the AC power source before (1) re-moving or reinstalling any component, circuit board, module or any other instrument assembly, (2) disconnecting any instrument electrical plug or other electrical connection, (3) connecting a test substitute in parallel with an electrolytic capacitor in the instrument.
- b. Do not defeat any plug/socket B+ voltage interlocks with which instruments covered by this service manual might be equipped.
- c. Do not apply AC power to this instrument and /or any of its electrical assemblies unless all solid-state device heat sinks are correctly installed.
- d. Always connect a test instrument's ground lead to the instrument chassis ground before connecting the test instrument positive lead. Always remove the test instrument ground lead last.

Note : Refer to the Safety Precautions section ground lead last.

- (2) The service precautions are indicated or printed on the cabinet, chassis or components. When servicing, follow the printed or indicated service precautions and service materials.
- (3) The components used in the unit have a specified flame resistance and dielectric strength. When replacing components, use components which have the same ratings. Components identified by shading, by (⚡) or by (⚡) in the circuit diagram are important for safety or for the characteristics of the unit. Always replace them with the exact replacement components.

(4) An insulation tube or tape is sometimes used and some components are raised above the printed wiring board for safety. The internal wiring is sometimes clamped to prevent contact with heating components. Install such elements as they were.

(5) After servicing, always check that the removed screws, components, and wiring have been installed correctly and that the portion around the serviced part has not been damaged and so on. Further, check the insulation between the blades of the attachment plug and accessible conductive parts.

1-2-2 Insulation Checking Procedure

Disconnect the attachment plug from the AC outlet and turn the power ON. Connect the insulation resistance meter (500V) to the blades of the attachment plug. The insulation resistance between each blade of the attachment plug and accessible conductive parts(see note) should be more than 1 Megohm.

Note : Accessible conductive parts include metal panels, input terminals, earphone jacks, etc.

1-3 ESD Precautions

Electrostatically Sensitive Devices (ESD)

Some semiconductor (solid state) devices can be damaged easily by static electricity.

Such components commonly are called Electrostatically Sensitive Devices(ESD). Examples of typical ESD devices are integrated circuits and some field-effect transistors and semiconductor chip components. The following techniques should be used to help reduce the incidence of component damage caused by static electricity.

- (1) Immediately before handling any semiconductor component or semiconductor-equipped assembly, drain off any electrostatic charge on your body by touching a known earth ground. Alternatively, obtain and wear a commercially available discharging wrist strap device, which should be removed for potential shock reasons prior to applying power to the unit under test.
- (2) After removing an electrical assembly equipped with ESD devices, place the assembly on a conductive surface such as aluminum foil, to prevent electrostatic charge buildup or exposure of the assembly.
- (3) Use only a grounded-tip soldering iron to solder or unsolder ESD devices.
- (4) Use only an anti-static solder removal devices. Some solder removal devices not classified as "anti-static" can generate electrical charges sufficient to damage ESD devices.
- (5) Do not use freon-propelled chemicals. These can generate electrical charges sufficient to damage ESD devices.
- (6) Do not remove a replacement ESD device from its protective package until immediately before you are ready to install it.(Most replacement ESD devices are packaged with leads electrically shorted together by conductive foam, aluminum foil or comparable conductive materials).

- (7) Immediately before removing the protective materials from the leads of a replacement ESD device, touch the protective material to the chassis or circuit assembly into which the device will be installed.

CAUTION : Be sure no power is applied to the chassis or circuit, and observe all other safety precautions.

- (8) Minimize bodily motions when handling unpackaged replacement ESD devices. (Otherwise harmless motion such as the brushing together of your clothes fabric or the lifting of your foot from a carpeted floor can generate static electricity sufficient to damage an ESD device).

1-4 Handling the optical pick-up

The laser diode in the optical pick up may suffer electrostatic breakdown because of potential static electricity from clothing and your body.

The following method is recommended.

- (1) Place a conductive sheet on the work bench (The black sheet used for wrapping repair parts.)
- (2) Place the set on the conductive sheet so that the chassis is grounded to the sheet.
- (3) Place your hands on the conductive sheet (This gives them the same ground as the sheet.)
- (4) Remove the optical pick up block
- (5) Perform work on top of the conductive sheet. Be careful not to let your clothes or any other static sources to touch the unit.
 - ◆ Be sure to put on a wrist strap grounded to the sheet.
 - ◆ Be sure to lay a conductive sheet made of copper etc. Which is grounded to the table.

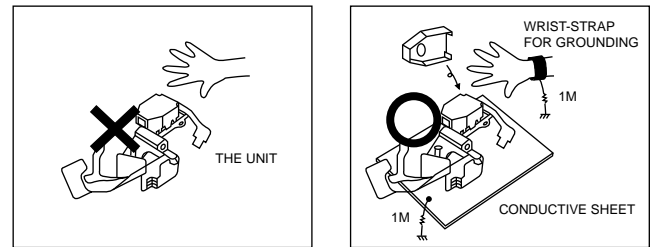

Fig.1-3

- (6) Short the short terminal on the PCB, which is inside the Pick-Up ASS'Y, before replacing the Pick-Up. (The short terminal is shorted when the Pick-Up Ass'y is being lifted or moved.)
- (7) After replacing the Pick-up, open the short terminal on the PCB.

1-5 Pick-up disassembly and reassembly

1-5-1 Disassembly

- 1) Remove the power cable.
- 2) Switch LD SW3 on deck PCB to "OFF" before removing the FPC
(Inserted into Main PCB CN6. See Fig. 1-4)
- 3) Disassemble the deck.
- 4) Disassemble the deck PCB.

1-5-2 Assembly

- 1) Replace the Pick-up.
- 2) Assemble the deck PCB.
- 3) Reassemble the deck.
- 4) Switch LD SW3 on Deck PCB to "ON" and insert FPC into Main PCB CN6 (See Fig 1-4).

Note : If the assembly and disassembly are not done in correct sequence, the Pick-up may be damaged.

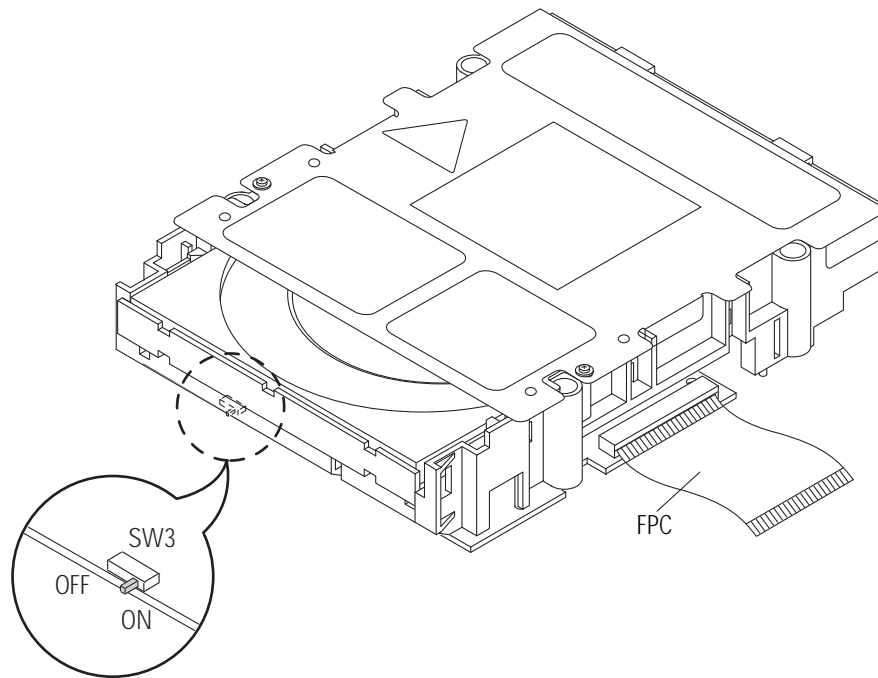
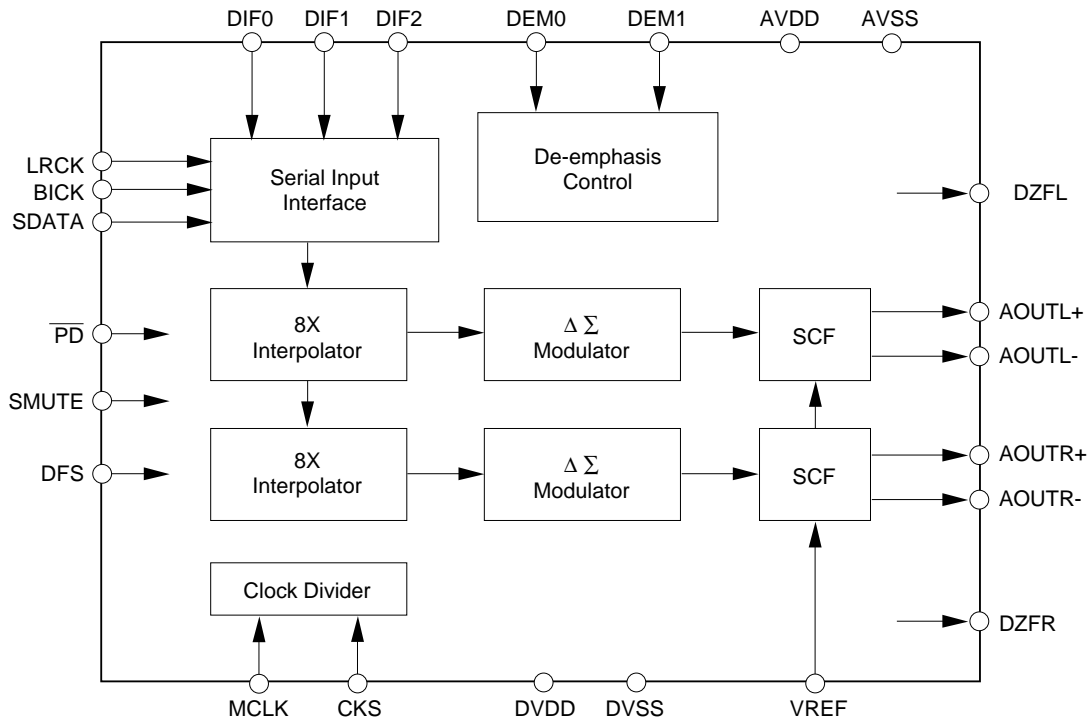

Fig. 1-4

2. Reference Information

2-1 IC Descriptions

2-1-1 AIC1 (AK4324 ; Digital-to-Analog Converter)



PIN	I/O	NAME	FUNCTION	PIN	I/O	NAME	FUNCTION
1	-	DVSS	Digital ground pin	13	I	DIF0	Digital input format pin
2	I	DVDD	Digital power supply	14	I	DIF1	Digital input format pin
3	I	CKS	Master clock select pin (Internal pull-down pin) Nomal speed "L":MCLK = 256fs, "H":MCLK = 384fs Double speed "L":MCLK = 128fs, "H":MCLK = 192fs	15	I	DIF2	Digital input format pin
4	I	MCLK	Master clock input pin	16	O	AOUTR-	Rch negative analog output pin
5	I	$\overline{\text{PD}}$	Power-Down mode pin. When at "L", the AK4324 is in power-down and is held in rest. The AK4324 should always be reset upon power-pin	17	O	AOUTR+	Rch positive analog output pin
6	I	BICK	Audio serial data input pin 64fs clock is recommended to be input on this pin	18	O	AOUTL-	Lch negative analog output pin
7	I	SDATA	Audio serial data input pin 2's complement MSB-first data is input on this pin.	19	O	AOUTL+	Lch positive analog output pin
8	I	LRCK	L/R clock pin.	20	-	AVSS	Analog ground pin
9	I	SMUTE	Soft mute pin When this pin goes "H", soft mute cycle is initiated When returning "L", the output mute releases.	21	O	VREF	Voltage reference input pin
10	I	DFS	Double speed sampling mode pin (Internal pull-down pin) "L":normal speed, "H":double speed	22	O	AVDD	Analog power supply pin.
11	I	DEM0	De-emphasis frequency select pin	23	O	DZFR	Rch zero input detect pin
12	I	DEM1	De-emphasis frequency select pin	24	O	DZFL	Lch zero input detect pin

Note : All input pins except internal pull-down pins should not be left floating.

2-1-2 RIC1 (KS1461 ; RF)

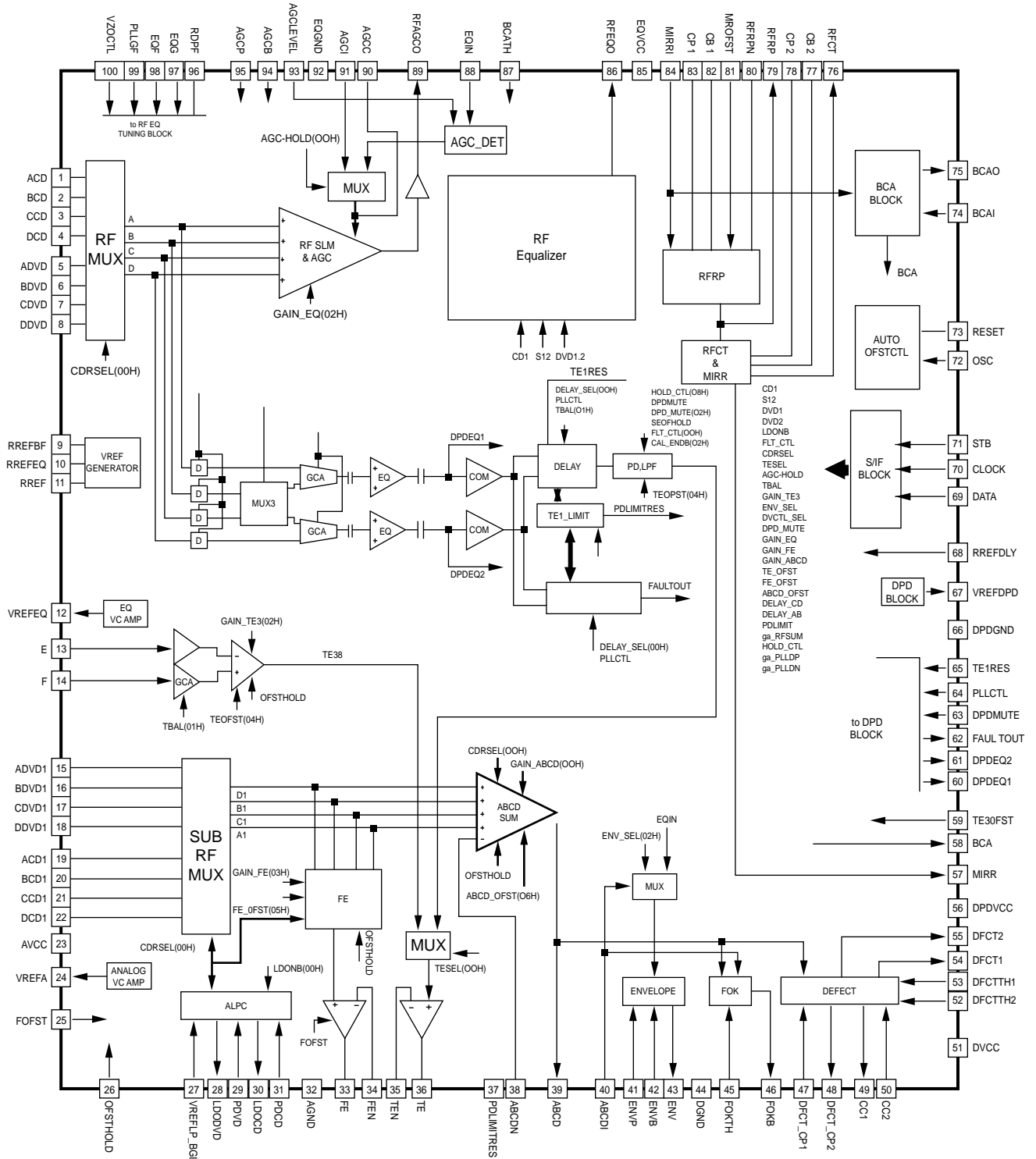

PIN NAME	I/O	FUNCTION
96	RDPF	Bias/resistance connection port for RF EQ frequency setting
97	EOG	RF EQ boost gain control voltage input port
98	EOF	RF EQ peak frequency control voltage input port
99	PLLG	RF EQ boost, peak frequency gain control port corresponding to wideband PLL (PLLG-PLL resistance internal design)
100	VZCCTL	RF EQ control port (When No. PLUG isn't adjusted, apply DC CTL voltage.)

PIN NAME	I/O	FUNCTION
65	TEIRES	DPD TE PLL variable bias resistance
66	DPDQND	Power GND input port for DPD TE
67	VREFDPD	CAP connection port for DPD TE center
68	RREFDLY	Bias resistance connection port for delta block
69	DATA	Data input port
70	CLOCK	Clock input port
71	STB	Data enable input port
72	OSC	OSC time constant input port for auto offset block
73	RESET	Reset input port for auto offset block (L : RESET)
74	BCAI	BCA FILTER
75	BCAO	BCA FILTER
76	RFC1	RF ripple center voltage output port for mirror
77	CB2	Bottom hold time constant RC connection port for RCT1 generation
78	CP2	Peak hold time constant RC connection port for RCT1 generation
79	RFRP	RF ripple AMP output port for mirror
80	RFRPN	RF ripple AMP GAIN input port for mirror
81	MROFST	RF ripple offset control port for mirror
82	CB1	Bottom hold time constant RC connection port for RCT1 generation
83	CP1	Peak hold time constant RC connection port for RCT1 generation
84	MIRRI	Input port for MIRR signal generation
85	EQVCC	Power voltage input port for RF EQ
86	RFEQO	RF EQ output port
87	BCATH	BCA comparing level control port
88	EQIN	RFAQCO input port for RF EQ
89	RFAQCO	RF AGC AMP output port
90	AGCC	AGC time constant CAP connection port
91	AGC1	When AGC is "HOLD", AGC voltage input port
92	EQGND	Power GND input port for RF EQ
93	AGCLEVEL	AGC level control voltage input port
94	AGCB	RF bottom hold time constant RC connection port for RF AGC
95	AGCP	RF peak hold time constant RC connection port for RF AGC

PIN NAME	I/O	FUNCTION
34	FEIN	FE input port for AMP GAIN setting
35	TEN	Input port for TE AMP GAIN setting
36	TE	TE AMP output port
37	PDLIMITRES	Bias resistance port for PDLIMIT
38	ABCDIN	Input port for ABCD AMP GAIN setting
39	ABCD	ABCD AMP output port
40	ABCD1	ABCD AC coupling input port for SERVO monitor
41	EWVP	Peak hold time constant setting RC connection port for RF envelope defect
42	ENWB	Bottom hold time constant setting RC connection port for RF envelope defect
43	ENV	RF envelope defect output port
44	DGND	Power GND input port for digital circuit
45	FOKTH	Focus OK comparing level input port
46	FOKB	Focus OK comparator output port (L: FOCUS OK)
47	DFCT_CP1	Peak hold time constant connection port SERVO defect max. time setting
48	DFCT_CP2	Peak hold time constant connection port PLL defect min. time setting
49	CC1	Output port of peak detector for defect
50	CC2	AC coupling input port for defect
51	DVCC	Power voltage input port for digital circuit
52	DFCTH2	Resistance connection port for PLL defect comparing level setting
53	DFCTH1	Resistance connection port for SERVO defect comparing level setting
54	DFCT1	Defect output port for SERVO
55	DFCT2	Defect output port for PLL
56	DPDVCC	Power voltage input port for DPD TE
57	MIRR	Mirror output port
58	BCA	BCA output port
59	TE3OFST	Resistance connection port for 3BTE offset
60	DPDEO1	DPD EQ (A-F) output port
61	DPDEO2	DPD EQ (B-F) output port
62	FAULTOUT	DPD defect waveform output port (MONITOR)
63	DPD0MUTE	DPD TE MUTE control port (H : MUTE)
64	PLLC1	DPD TE PLL variable input port

PIN NAME	I/O	FUNCTION
1	ACD	CD optical main beam A AC coupling input port for RF
2	BCD	CD optical main beam B AC coupling input port for RF
3	CCD	CD optical main beam C AC coupling input port for RF
4	DCD	CD optical main beam D AC coupling input port for RF
5	ADVD	DVD optical main beam A AC coupling input port for RF
6	BDVD	DVD optical main beam B AC coupling input port for RF
7	CDVD	DVD optical main beam C AC coupling input port for RF
8	DDVD	DVD optical main beam D AC coupling input port for RF
9	RREFBF	RF AMP I/O buffer bias/resistance connection port
10	RREFEO	RF EQ bias/resistance connection port
11	RREF	Analog block bias/resistance connection port
12	VREFEQ	CAP connection port for RF EQ center voltage
13	E	CD optical sub beam E input port for SERVO
14	F	CD optical sub beam F input port for SERVO
15	ADVD1	DVD optical main beam A input port for SERVO
16	BDVD1	DVD optical main beam B input port for SERVO
17	CDVD1	DVD optical main beam C input port for SERVO
18	DDVD1	DVD optical main beam D input port for SERVO
19	ACD1	CD optical main beam E input port for SERVO
20	BCD1	CD optical main beam F input port for SERVO
21	CCD1	CD optical main beam F input port for SERVO
22	DCD1	CD optical main beam F input port for SERVO
23	AVCC	Power voltage input port for analog part
24	VREFA	CAP connection port for analog part center voltage. Use at other block
25	FOFST	CAP connection port for focus auto offset (OPEN)
26	OFSTHOLD	ON/OFF connection port for auto offset block (L : auto offset adjustment H : serial offset adjustment)
27	VREFP_LBG1	BANDGAP voltage input port for ALPC
28	LD0VD	DVD optical laser diode driving voltage output port
29	PD0VD	DVD optical laser monitor diode voltage input port
30	LD0CD	CD optical laser diode driving voltage output port
31	PD0CD	CD optical laser monitor diode voltage input port
32	AGND	Power GND port for analog part
33	FE	FE AMP output port

2-1-3 SIC1 (KS1452 ; Digital Servo)

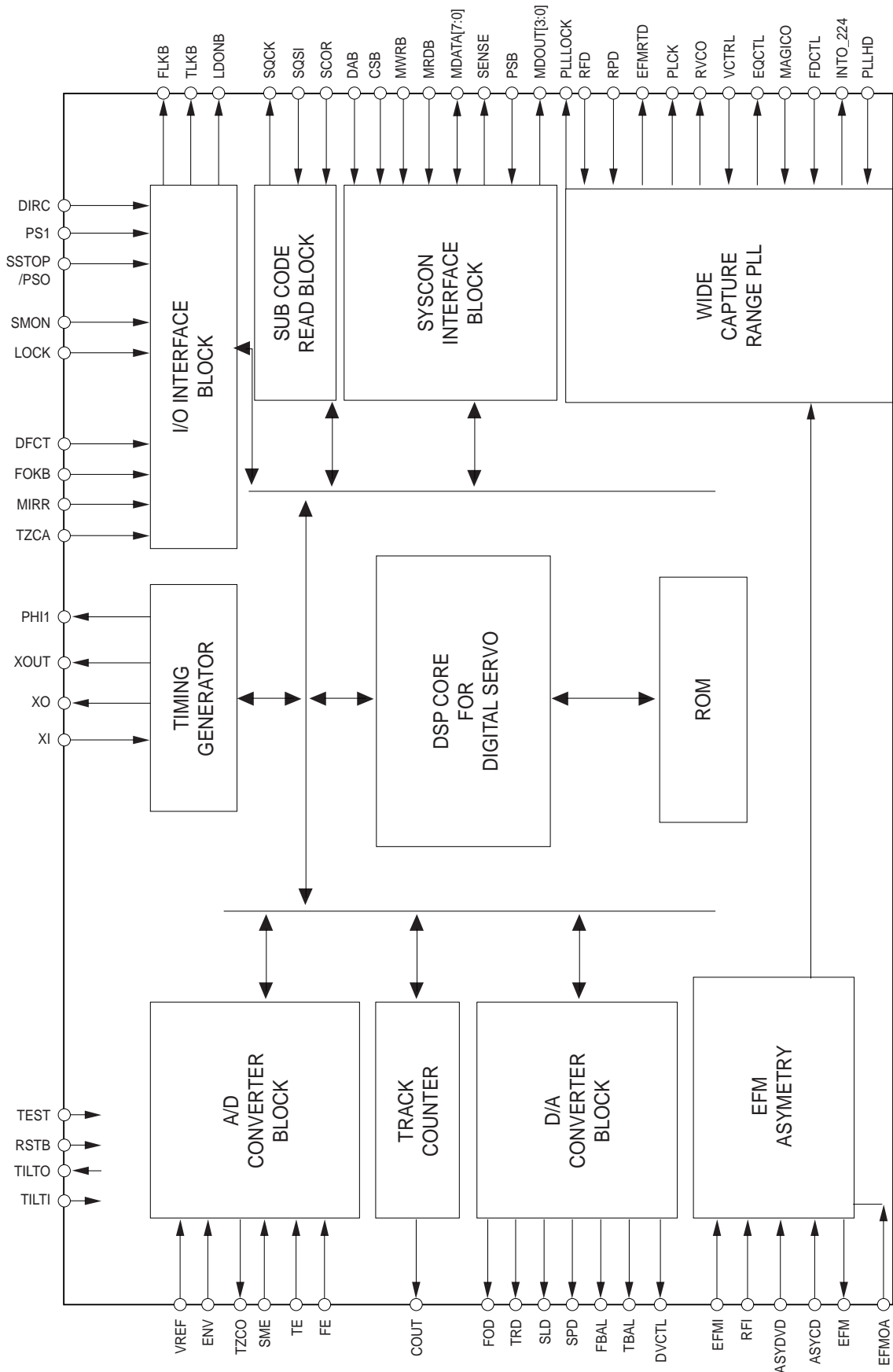

PIN NAME	I/O	FUNCTION
1	MDOU13	Mode data3 out controlled by micom
2	SSTOP/PSO	Limit switch/sled position sensor input pin0
3	PS1	Sled motor position sensor input pin 1
4	TEST	Test pin (L : normal H : test)
5	COU1	Counter clock
6	FLKB	Focus servo lock signal output pin
7	TLKB	Tracking servo lock signal output pin
8	PSB	0 : BIT 1 : 8BIT
9	RSTB	System reset signal input pin
10	CSB	Micom chip select pin
11	DAB	Micom data/address select pin
12	MWRB	Micom write clock signal input pin
13	MRGB	Micom read clock signal input pin
14	MDATA0	Micom data pin 0
15	MDATA1	Micom data pin 1
16	MDATA2	Micom data pin 2
17	MDATA3	Micom data pin 3
18	MDATA4	Micom data pin 4
19	MDATA5	Micom data pin 5
20	MDATA6	Micom data pin 6
21	MDATA7	Micom data pin 7
22	SENSE	Internal status monitor pin
23	DVDD	Servo logic & ROM VDD power supply pin
24	X1	System clock signal input pin
25	X0	System clock signal output pin
26	XOUT	Clock out (33.668MHz) to DSP
27	DVSS	Servo logic & ROM VSS power supply pin
28	SOCK	Clock output pin for subcode data read
29	SOSI	Subcode data input pin
30	SCOR	Timing detection input pin for subcode data read
31	SMON	Motor ON signal input pin
32	LOCK	Lock signal input pin
33	DIRC	Direct jump control (for 1 track jump)

PIN NAME	I/O	FUNCTION
34	FOKB	Focus OK signal input pin
35	FDCTL	PLL frequency detect control input pin
36	LDO1B	Laser diode ON signal output pin
37	DECT	Detect Detection signal input pin
38	M1RR	Minor signal input pin
39	PL1HD	PLL hold signal from micom
40	INTO_224	Servo interrupt monitor pin
41	PVDD	PLL logic block VDD power supply pin
42	PLCK	PLCK
43	PULLOCK	Frequency lock detect output (H : Lock L : Unlock)
44	EFMR1D	Latched EFM output signal
45	PVSS	PLL logic block VSS power supply pin
46	RVCO	Resistor pin for VCO GAIN
47	RFD	Gain adjust resistor for frequency detector
48	RPD	Gain adjust resistor for phase detector
49	VCTL	Control voltage for VCO
50	MAG1CO	Input for hysteresis control of FD output (for test)
51	EFMOA	EFM offset adjustment pin
52	TZCO	Tracking zero cross output pin
53	SVDD	Servo CPU VDD power supply pin
54	EOCTL	EO control signal
55	EFMI	EFM signal for test
56	EFMO	EFM signal
57	L1FDVD	Asymmetric input signal for DVD
58	LP1CD	Asymmetric input signal for CD
59	RFI	RF input signal
60	SVSS	Servo CPU VSS power supply pin
61	AVSS	Analog block VSS power supply pin
62	SME	Spindle error input pin
63	VREF	Reference voltage input pin
64	TE	Tracking error signal input pin

PIN NAME	I/O	FUNCTION
65	FE	Focus error signal input pin
66	ENV	RF envelope input pin
67	TILT1	Tilt in (reserved)
68	AVDD	Analog block VDD power supply pin
69	TILT0	Tilt out (reserved)
70	DVCTL	Depth variation control signal output pin
71	TBAL	Tracking balance signal output pin
72	FBAL	Focus balance signal output pin

PIN NAME	I/O	FUNCTION
73	SID	Sled motor drive signal output pin
74	SPD	Spindle motor drive signal output pin
75	FOD	Focus actuator drive signal output pin
76	TRD	Tracking actuator drive signal output pin
77	TZCA	TE signal for tracking zero cross input pin
78	MDOU10	Mode data 0 out controlled by micom
79	MDOU11	Mode data 1 out controlled by micom
80	MDOU12	Mode data 2 out controlled by micom

2-1-4 DIC1 (KS1453 ; DVD Data Processor)

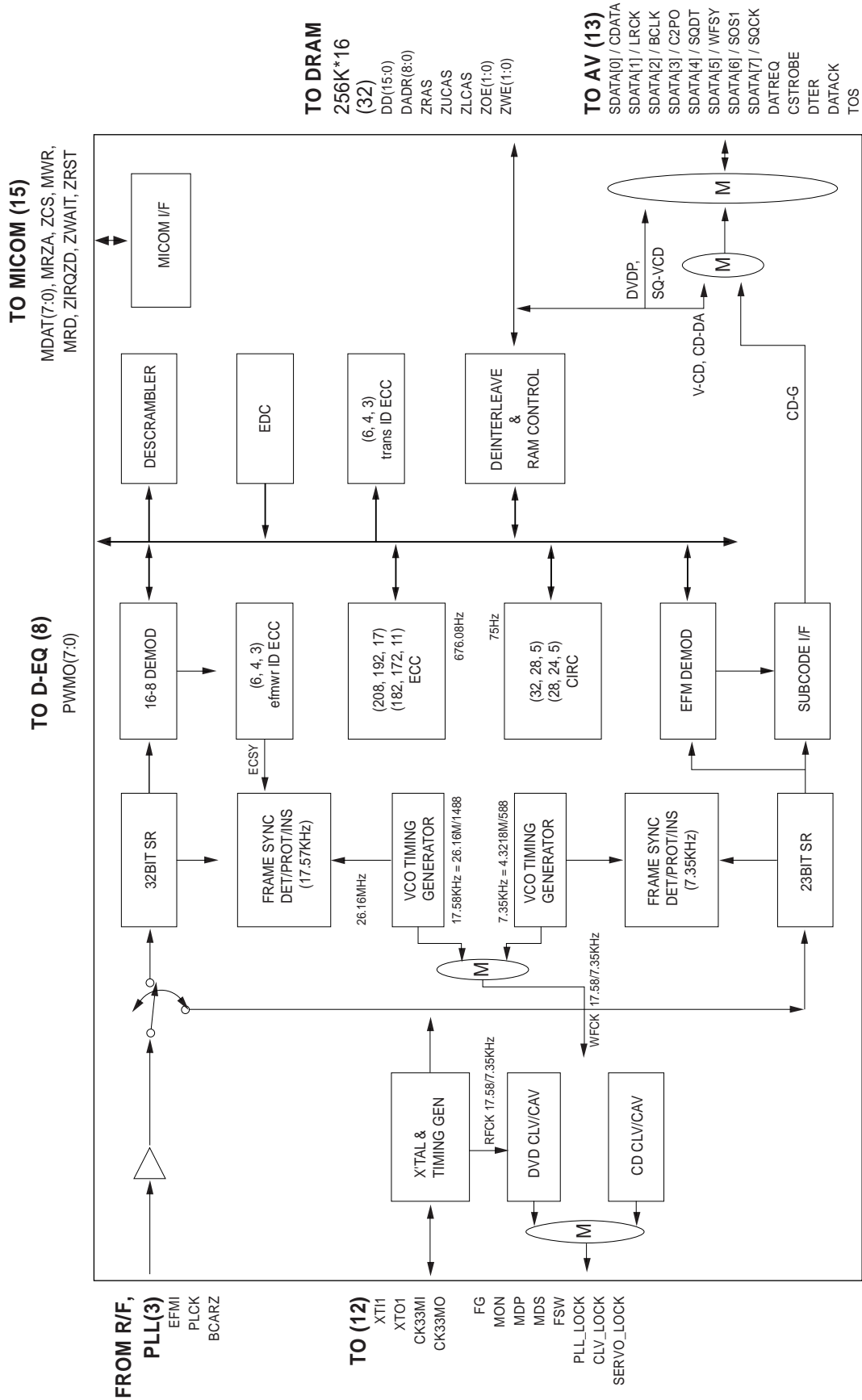

PIN	NAME	FUNCTION
98	TEST0_IN	Test mode setting port
99	TEST1_IN	Test mode setting port
100	TEST2_IN	Test mode setting port
101	EFM0_OUT	EFM out
102	WFCK_OUT	Write frame pulse
103	RFCK_OUT	Reference frame pulse
104	PCK_IN	Phase locked clock
105	DVSS	Digital GND (0V)
106	PLLCK_OUT	Lock signal for PLL
107	CLVCK_OUT	Lock signal for CLV
108	SERLOCK_OUT	Lock signal for SERVO
109	MDP_OUT	Spindle motor phase control signal (β state)
110	MDS_OUT	Spindle motor speed control signal (β state)
111	DVSS	Digital GND (0V)
112	DVSS	Digital GND (0V)
113	MON_OUT	Spindle motor ON/OFF control output
114	FG_IN	Reference signal for CAV
115	FSW_OUT	Spindle motor output filter conversion output (β state)
116	EFM_IN	EFM/EFM+ signal input
117	DVDD	Digital power (+5V)
118	DVDD	Digital power (+5V)
119	DVDD	Digital power (+5V)
120	CK16M_OUT	2 $\frac{1}{2}$ -x clock of CK33M/16.934MHz
121	DEMPHA_OUT	When DEEMPHASIS is ON - "HIGH".
122	BCARZ_IN	BCA input signal
123	DVSS	Digital GND (0V)
124	ZRST_IN	Hardware reset active low
125	ZWAIT_OUT	Micom read/write access wait ("L" wait)
126	ZRQZD_OUT	Interrupt request from micom
127	MRO_IN	Micom read strobe (schmitt trigger)
128	MWR_IN	Micom write strobe (schmitt trigger)

PIN	NAME	FUNCTION
66	SDATA6_OUT	DVD data/Sub code block sink (SSS1)
67	SDATA7_BI	DVD data/Sub code serial clock (SOCK)
68	DVSS	Digital GND (0V)
69	CSTROBE_OUT	Data strobe (clock) output
70	DATREQ_IN	Data request from A/V decoder or ROM decoder
71	DTERR_OUT	DVD data error output
72	DVSS	Digital GND (0V)
73	PWM07_OUT	PWM output signal
74	PWM08_OUT	PWM output signal
75	PWM05_OUT	PWM output signal
76	PWM04_OUT	PWM output signal
77	DVDD	Digital power (+5V)
78	PWM03_OUT	PWM output signal
79	PWM02_OUT	PWM output signal
80	PWM01_OUT	PWM output signal
81	PWM00_OUT	PWM output signal
82	DVSS	Digital GND (0V)
83	DVSS	Digital GND (0V)
84	DVSS	Digital GND (0V)
85	DVDD	Digital power (+5V)
86	DVDD	Digital power (+5V)
87	DVSS	Digital GND (0V)
88	DVSS	Digital GND (0V)
89	DVSS	Digital GND (0V)
90	DVSS	Digital GND (0V)
91	FRSYZ_OUT	Frame sync out
92	TX_OUT	Digital out
93	GF5_OUT	Good frame sync detection result output ("H" active)
94	DVSS	Digital GND (0V)
95	CK33M_IN	System clock input for 33.6688MHz
96	CK33M0_OUT	System clock output for 33.6688MHz
97	DVSS	Digital GND (+5V)

PIN	NAME	FUNCTION
33	DD6_BI	DRAM data bus
34	DD8_BI	DRAM data bus
35	DD7_BI	DRAM data bus
36	DVSS	Digital GND (0V)
37	ZUCAS_OUT	DRAM row column address strobe
38	ZUCAS_OUT	DRAM upper column address strobe
39	ZWEI_OUT	DRAM write enable 1 (BM ONLY)
40	ZWER_OUT	DRAM write enable 0 (AM, BM, 16M)
41	ZOEI_OUT	DRAM output enable 1 (16M,, 16M)
42	DVDD	Digital power (+5V)
43	ZGEO_OUT	DRAM output enable 0
44	ZRAS_OUT	DRAM row address strobe
45	DADR8_OUT	DRAM address bus
46	DADR7_OUT	DRAM address bus
47	DVSS	Digital GND (0V)
48	DADR0_OUT	DRAM address bus
49	DADR6_OUT	DRAM address bus
50	DADR1_OUT	DRAM address bus
51	DADR5_OUT	DRAM address bus
52	DADR2_OUT	DRAM address bus
53	DADR4_OUT	DRAM address bus
54	DADR3_OUT	DRAM address bus
55	DVSS	Digital GND (0V)
56	DVSS	Digital GND (0V)
57	TOS_OUT	Top of sector
58	DRAACK_OUT	Data acknowledge signal output
59	DVDD	Digital power (+5V)
60	SDATA0_OUT	DVD data/CD data bitstream output
61	SDATA1_OUT	DVD data/CD data L/R clock (LRCK)
62	SDATA2_OUT	DVD data/CD data bit clock (BCLK)
63	SDATA3_OUT	DVD data/CD data error flag (C2P0)
64	SDATA4_OUT	DVD data/Sub code serial data (SCDT)
65	SDATA5_OUT	DVD data/Sub code frame sink (WFSY)

PIN	NAME	FUNCTION
1	DVSS	Digital GND (0V)
2	ZCS_IN	Chip select (Active Low)
3	MARZA_IN	Micom register select (L -> Register H -> Data)
4	DVSS	Digital GND (0V)
5	MDAT7_BI	Micom data bus
6	MDAT6_BI	Micom data bus
7	MDAT5_BI	Micom data bus
8	MDAT4_BI	Micom data bus
9	MDAT3_BI	Micom data bus
10	MDAT2_BI	Micom data bus
11	MDAT1_BI	Micom data bus
12	MDAT0_BI	Micom data bus
13	DVDD	Digital power (+5V)
14	XTL_IN	System clock input for 26.16 MHz
15	XTO_OUT	System clock output for 26.16 MHz
16	DVSS	Digital GND (0V)
17	DD15_BI	DRAM data bus
18	DD0_BI	DRAM data bus
19	DD14_BI	DRAM data bus
20	DD1_BI	DRAM data bus
21	DVSS	Digital GND (0V)
22	DD13_BI	DRAM data bus
23	DD2_BI	DRAM data bus
24	DD12_BI	DRAM data bus
25	DD3_BI	DRAM data bus
26	DVDD	Digital power (+5V)
27	DD11_BI	DRAM data bus
28	DD4_BI	DRAM data bus
29	DD10_BI	DRAM data bus
30	DD5_BI	DRAM data bus
31	DVSS	Digital GND (0V)
32	DD9_BI	DRAM data bus

2-1-5 DIC2 (KM416C254BJ-6 ; CMOS DRAM)

BLOCK DIAGRAM

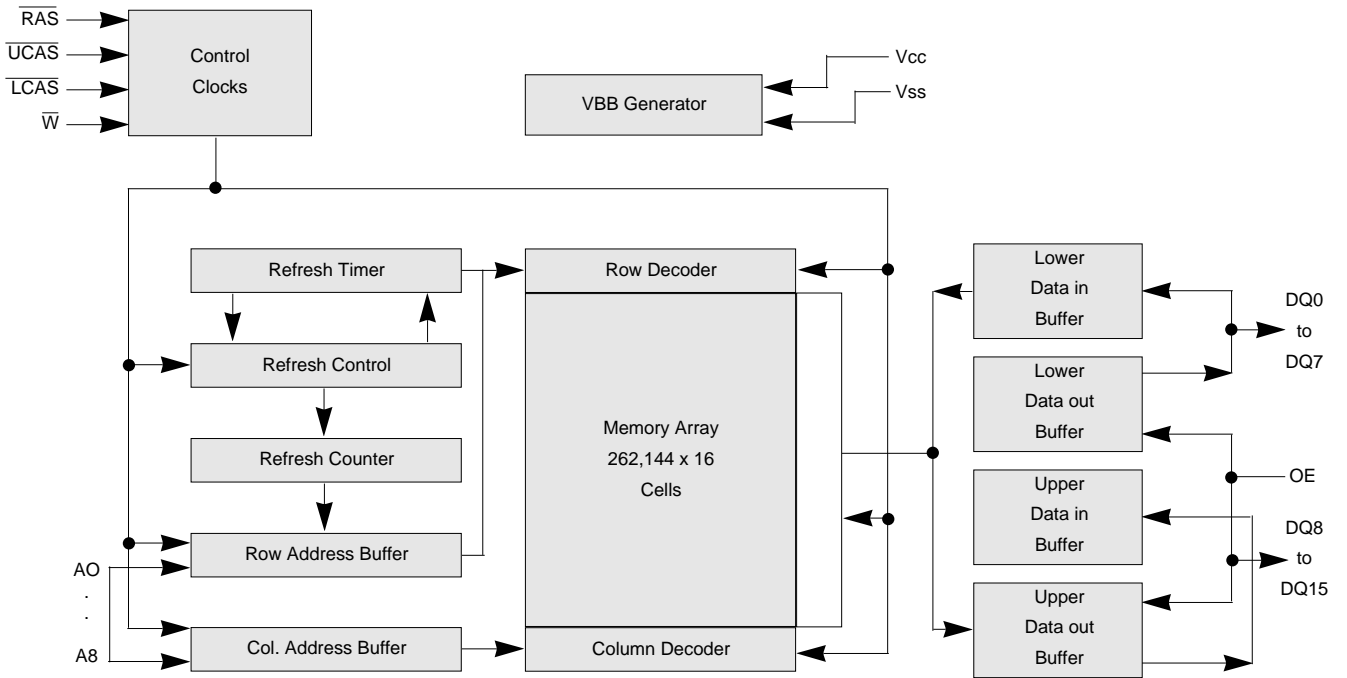

NAME	FUNCTION
A0-A8	Address Inputs
DQ0-15	Data in/Out
VSS	Ground
$\overline{\text{RAS}}$	Row Address Strobe
$\overline{\text{UCAS}}$	Upper Column Address Strobe
$\overline{\text{LCAS}}$	Lower Column Address Strobe
$\overline{\text{W}}$	Read/Write Input
$\overline{\text{OE}}$	Data Output Enable
V _{cc}	Power (+5V)
	Power (+3.3V)
N.C	No Connection

2-1-6 VIC1 (ZiVA-3 ; Audio/Video Decoder)

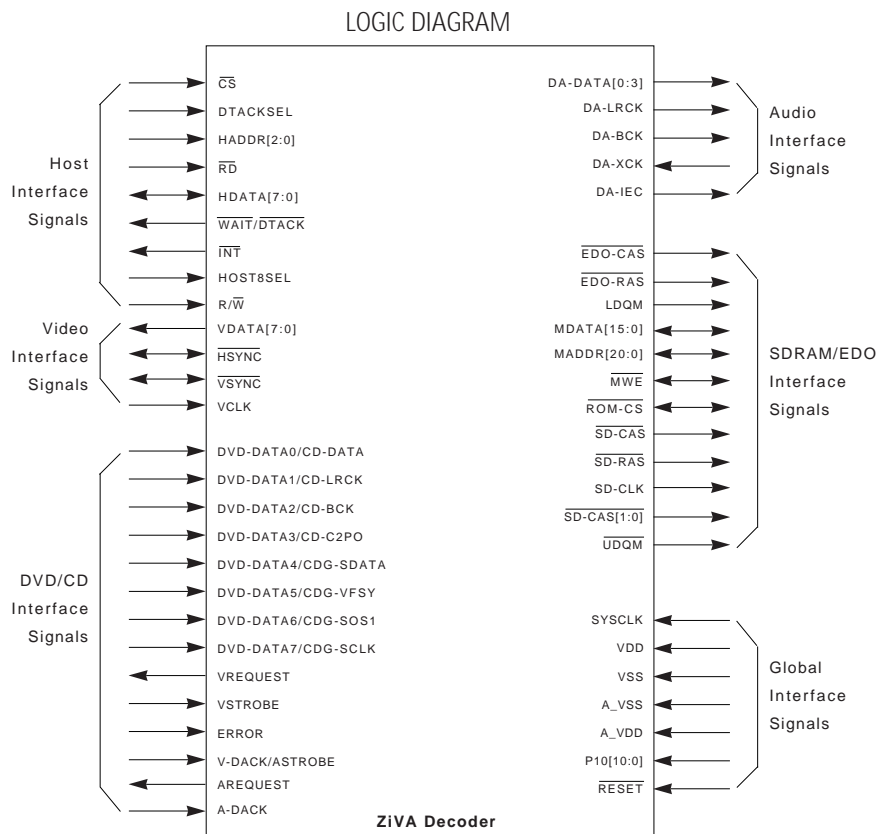
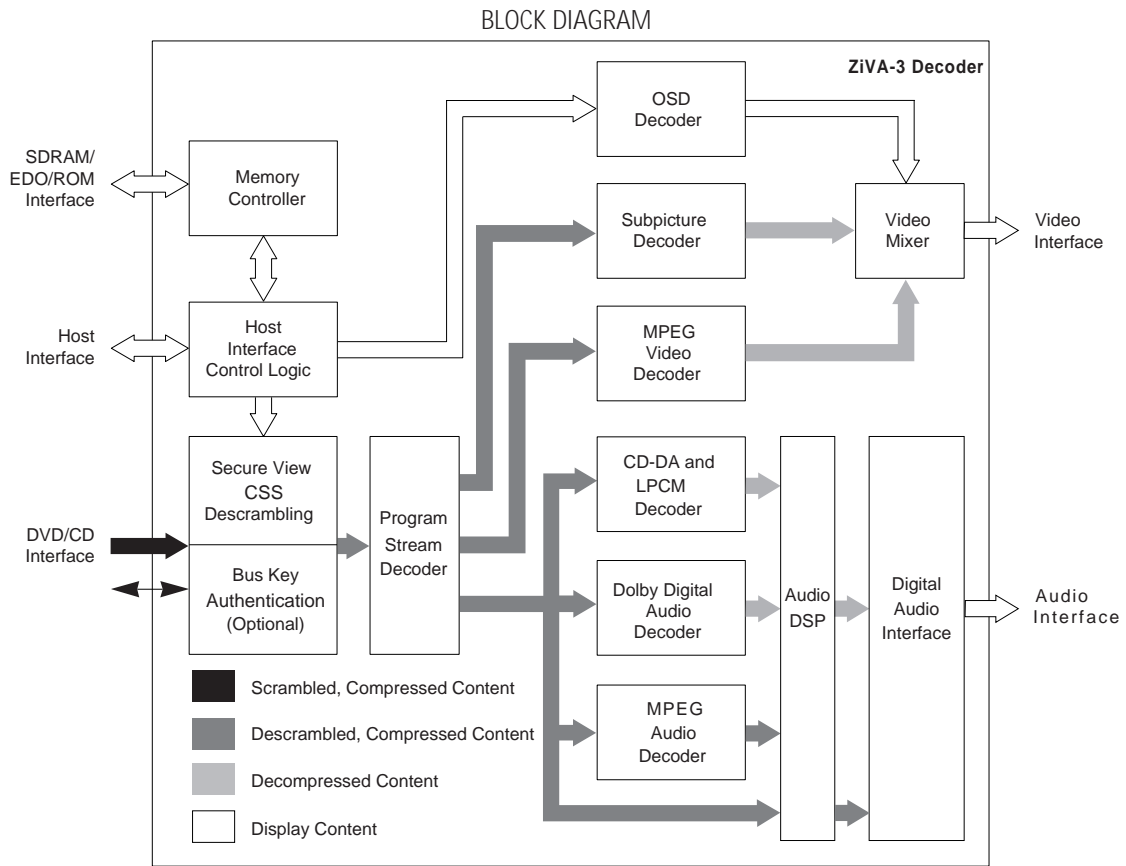

2-1-7 VIC50 (SAA7128 ; Digital Video Encoder)

BLOCK DIAGRAM

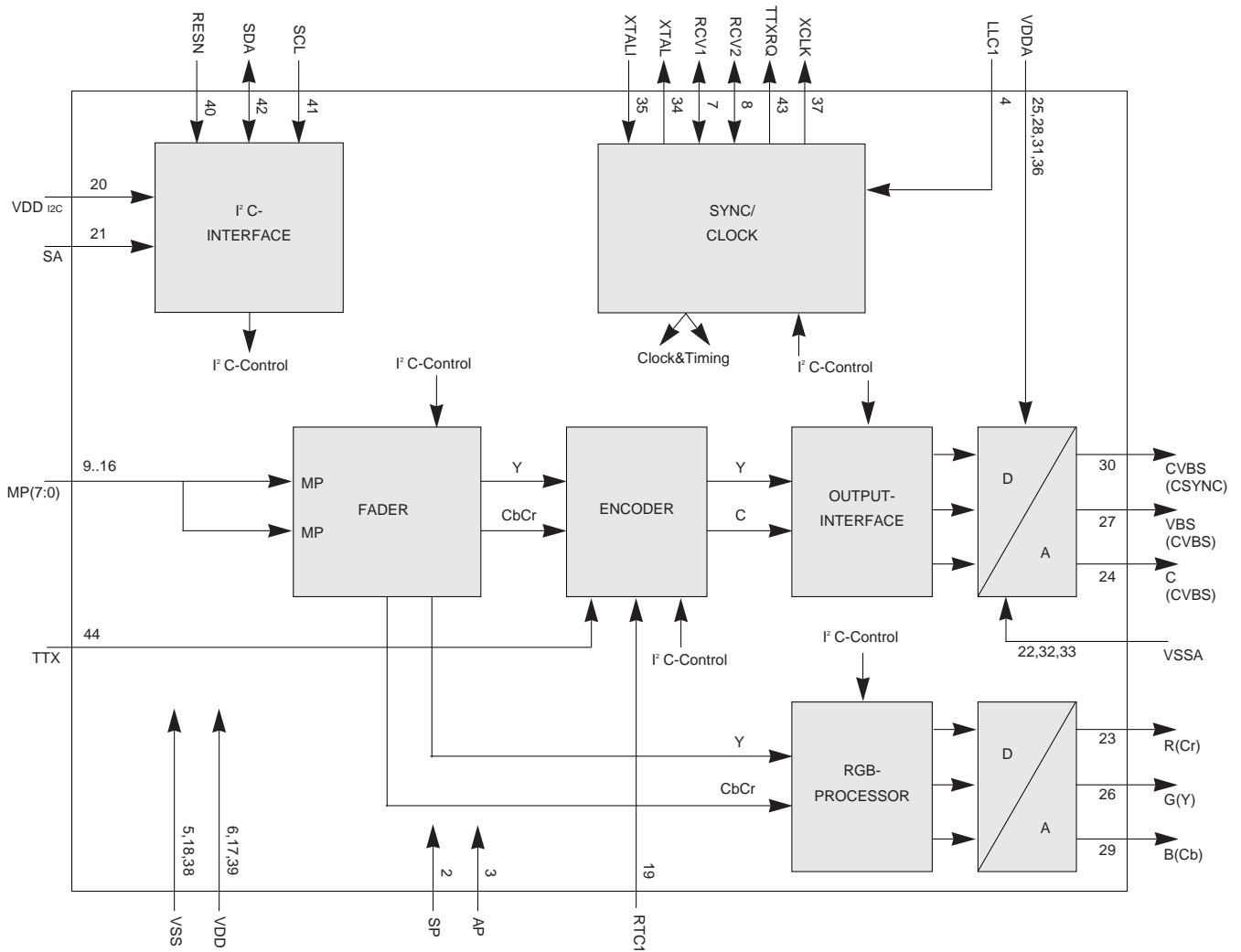

PIN	I/O	NAME	FUNCTION
1		res.	Reserved pin, do not connect
2	I	SP	Test Pin;connected to digital ground for normal operation
3	I	AP	Test Pin;connected to digital ground for normal operation
4	I	LLC1	Line-Locked Clock input;this is the 27 MHz master clock
5	I	V _{SS1}	Digital supply ground 1
6	I	V _{DD1}	Digital supply 1
7	I/O	RCV1	Raster Contral 1 for video port. This pin receives/provides a VS/FS/FSEQ signal.
8	I/O	RCV2	Raster Contral 2 for video port. This pin provides an HS pulse of programmable length or receives an HS pulse.

PIN	I/O	NAME	FUNCTION
9	I	MP7	Double speed 54 MHzMPEG port. It is an input for "CCIR 656" style multiplexed Cb, Y, Cr data. Data are sampled on the rising and falling clock edge; data sampled on the rising edge then are sent to the encoding part of the device, data sampled on the falling edge are sent to the RGB part of the device. (or vice verse, depending on programming)
10	I	MP6	
11	I	MP5	
12	I	MP4	
13	I	MP3	
14	I	MP2	
15	I	MP1	
16	I	MP0	
17	I	V _{DD2}	Digital supply voltage 2
18	I	V _{SS2}	Digital ground 2
19	I	RTCI	Real Time Control input. If the LLC1 clock is provided by an SAA7111 or SAA7151B, RTCI should be connected to the RTCO pin of the respective decoder to improve the signal quality.
20	I	VDD _{12C}	Sense input for 12C bus voltage; connect to 12C bus supply
21	I	SA	Select 12C address; low selects slave address 88h, high selects slave address 8Ch.
22	I	V _{SSA1}	Analog ground 1 for Red (Cr), C(CVBS), Green(Y) outputs
23	O	R(Cr)	Analog output of Red (Cr) signal
24	O	C	Analog output of Chrominance (CVBS) signal
25	I	V _{DDA1}	Analog supply voltage 1 for R(Cr), C(CVBS) outputs
26	O	G(Y)	Analog output of Green(Y) signal
27	O	VBS	Analog output of VBS (CVBS) signal
28	I	V _{DDA2}	Analog supply voltage 2 for VBS(CVBS), Green(Y) outputs
29	O	B(Cb)	Analog output of Blue(Cb) signal
30	O	CVBS	Analog output of CVBS(CSYNC) signal
31	I	V _{DDA3}	Analog supply voltage 3 for Blue(Cb) and CVBS(CSYNC), outputs
32	I	V _{SSA2}	Analog ground 2 for VBS (CVBS), Blue(Cb), CVBS(CSYNC) outputs
33	I	V _{SSA3}	Analog ground 3 for the DAC reference ladder and the oscillator
34	O	XTAL	Crystal oscillator output
35	I	XTAL1	Crystal oscillator input; if the oscillator is not used, this pin should be connected to ground.
36	I	V _{DDA4}	Analog supply voltage 4 for the DAC reference ladder and the oscillator
37	O	XCLK	Clock output of the crystal oscillator
38	I	V _{SS3}	Digital supply ground 3
39	I	V _{DD3}	Digital supply 3
40	I	RESN	Reset input, active LOW. After reset is applied, all digital I/Os are in input mode; PAL-Blackburst on CVBS, VBS and C; RGB outputs set to lowest voltage. The 12C-bus receiver waits for the START condition.
41	I	SCL	12C serial clock input
42	I/O	SDA	12C serial data input/output
43	O	TTXRO	Teletext Request output, indicating when text bits are requested
44	I	TTX	Teletext bit stream input

2-1-8 MIC1 (TMP93CM41F ; Main Micom)

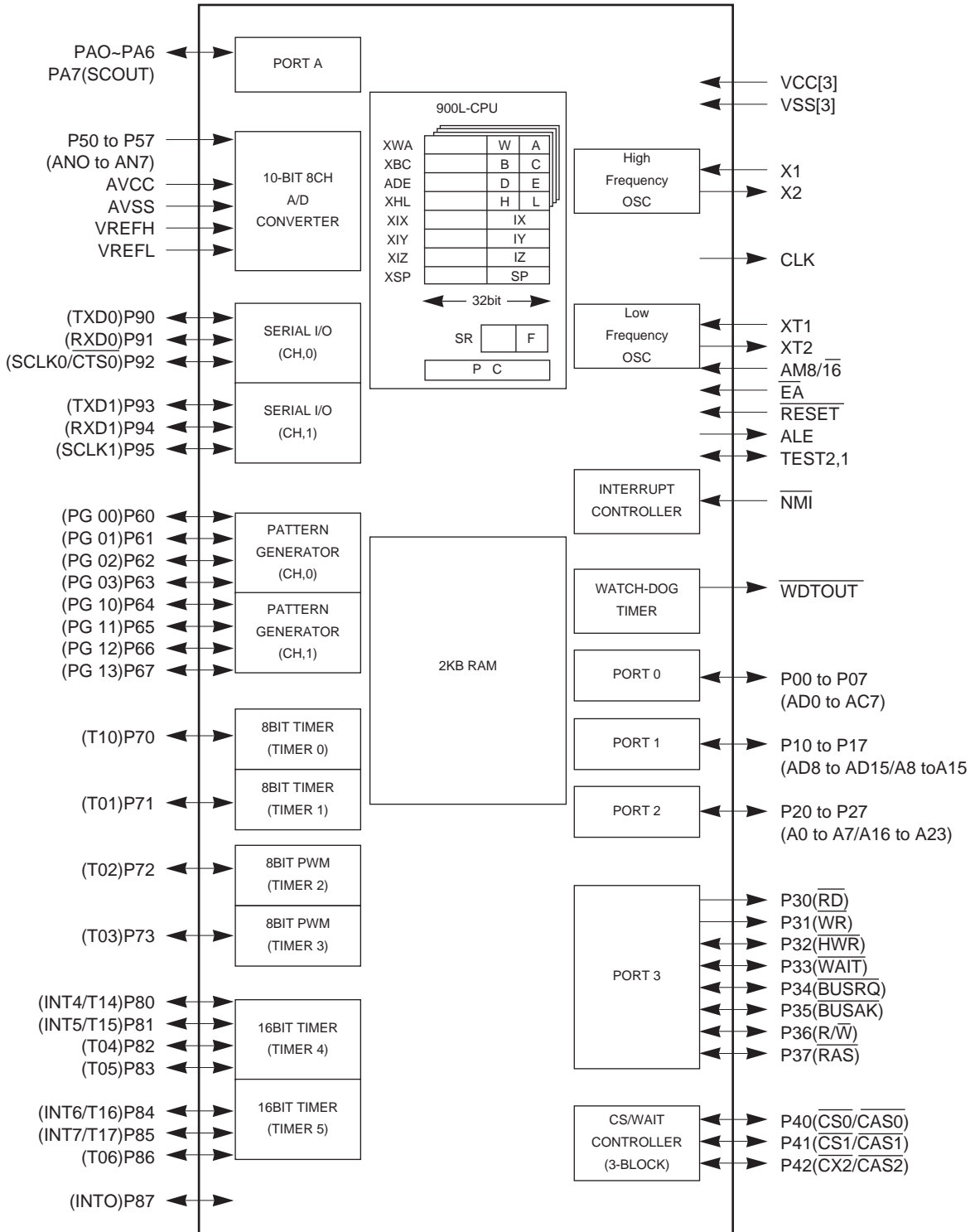

No	PORT NAME	ASSIGNED NAME	I/O	FUNCTION
82	/CS2	/CS2	0	Chip select 2 (EPROM, 4M Bit, 512KB)
83	P60	-	I/O	
84	P61	TRAY-IN	0	Tray in control output
85	P62	TRAY-OUT	0	Tray out control output
86	P63	SCL	0	IIC-clock (VIDEO-ENCODER)
87	P64	SDA	I/O	IIC-clock (VIDEO-ENCODER)
88	P65	DAB	0	D.Servo IC data/Address select
89	P66	CSB	0	D.Servo IC chip select
90	P67	RSTB	0	D.Servo IC reset
91	VSS	GND	-	
92	P90	SLOCK	0	LOCK monitor from DSP
93	P51	TILT0	1	Monitor signal
94	P52	FR	1	Spindle direction from SP driver
95	P53	SENSE	1	SENSE monitor from SERVO
96	P54	FOXB	1	Focus lock monitor from RF
97	P55	RFRT1	1	Tracking lock monitor from SERVO
98	P56	RFO	1	RF sum signal
99	P57	VREF0	1	
100	VREFH	AVCC	1	A/D Ref input (H)

No	PORT NAME	ASSIGNED NAME	I/O	FUNCTION
61	/WDOUT	WDOUT	0	Watch dog timer output
62	VSS	GND	-	
63	Vcc	VCC	-	
64	A16	HA16	0	Address 16
65	A17	HA17	0	Address 17 (AV-DECODER)
66	A18	HA18	0	Address 18 (Data processor)
67	A19	HA19	0	Address 19
68	A20	HA20	0	Address 20 (D. SERVO)
69	A21	HA21	0	Address 21
70	A22	HA22	0	Address 22
71	A23	HA23	0	Address 23
72	/RD	/RD	0	/Read strobe
73	/WR	/WR	0	/Write strobe
74	P32	-	I/O	
75	/WAIT	/MWAIT	1	/Wait
76	P34	RCODE	I/O	
77	P35	-	I/O	
78	P36	-	0	
79	P37	-	I/O	
80	P40/CS0	-	0	
81	/CS1	/CS1	-	Chip select 1 (SRAM, 1M Bit, 28KB)

No	PORT NAME	ASSIGNED NAME	I/O	FUNCTION
31	P66	XT1	0	-
32	P97	XT2	0	-
33	TEST1	TEST1	-	Test pin, connect to TEST2
34	TEST2	TEST2	-	Test pin, connect to TEST1
35	PA0	ECK	0	EEPROM CLOCK
36	PA1	EDT	I/O	EEPROM DATA I/O
37	PA2	EWC	0	EEPROM WRITE PROTECT
38	PA3	-	0	
39	PA4	-	0	
40	PA5	-	0	
41	PA6	-	0	
42	PA7	-	0	
43	ALE	ALE	0	Address latch enable
44	Vcc	VCC	-	
45	AD0	HAD0	I/O	Address/Data 0
46	AD1	HAD1	I/O	Address/Data 1
47	AD2	HAD2	I/O	Address/Data 2
48	AD3	HAD3	I/O	Address/Data 3
49	AD4	HAD4	I/O	Address/Data 4
50	AD5	HAD5	I/O	Address/Data 5
51	AD6	HAD6	I/O	Address/Data 6
52	AD7	HAD7	I/O	Address/Data 7
53	A8	HAD8	0	Address 8
54	A9	HAD9	0	Address 9
55	A10	HAD10	0	Address 10
56	A11	HAD11	0	Address 11
57	A12	HAD12	0	Address 12
58	A13	HAD13	0	Address 13
59	A14	HAD14	0	Address 14
60	A15	HAD15	0	Address 15

No	PORT NAME	ASSIGNED NAME	I/O	FUNCTION
1	VREFL	GND	1	A/D Ref input (L)
2	AVSS	AGND	-	A/D GND input
3	AVCC	AVCC	-	A/D VCC input
4	/NMI	-	1	Non-maskable interrupt
5	P70	ZRST	0	DSP H/W reset
6	P71	MCK_SEL	0	Master clock select
7	P72	ZVAL_RST	0	AV-DEC H/W reset
8	P73	LED	0	Open/close blinking
9	/INT4	DVDINT	1	Interrupt from AV-DEC
10	INT5	SRQ	1	Interrupt from front microm
11	P82	OPEN	1	Open switch
12	P83	CLOSE	1	Close switch
13	/INT6	FGINT	1	Interrupt from spindle motor FG
14	INT7	-	1	
15	P86	RREQ	0	Request to front microm
16	INT0	ZINT	1	Interrupt from DSP
17	TXD0	RXD	0	Serial data output
18	RXD0	TXD	1	Serial data input
19	SCLK0	SCLK	1	Serial data clock
20	TXD1	MD	0	RF control data
21	094	STB	I/O	RF data latch
22	SCLK1	MC	0	RF control clock
23	AM8/76	AM8	1	Address mode (H: 8 bit mode)
24	CLK	CLK	0	Clock output (System clock+2)
25	Vcc	VCC	-	
26	VSS	GND	-	
27	X1	X1	1	High frequency OSC in
28	X2	X2	0	High frequency OSC out
29	/EA	/EA	1	External access CSA1/CSA0
30	/RESET	/MRST	1	Master reset from FRONT

2-1-9 MIC8 (M27C801 ; 8MB (1M x 8-bit) CMOS EPROM)

BLOCK DIAGRAM

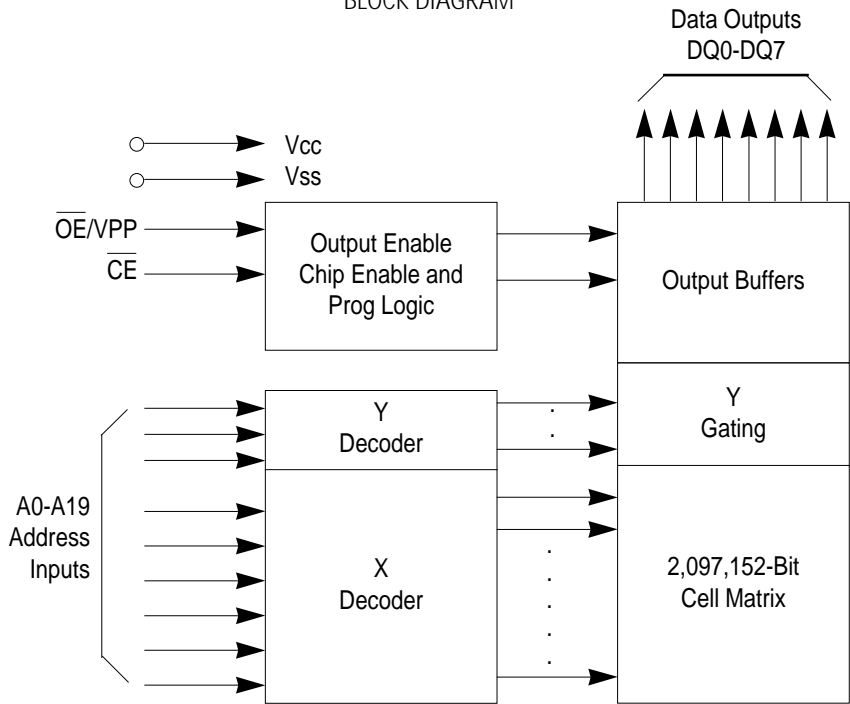

TOP VIEW

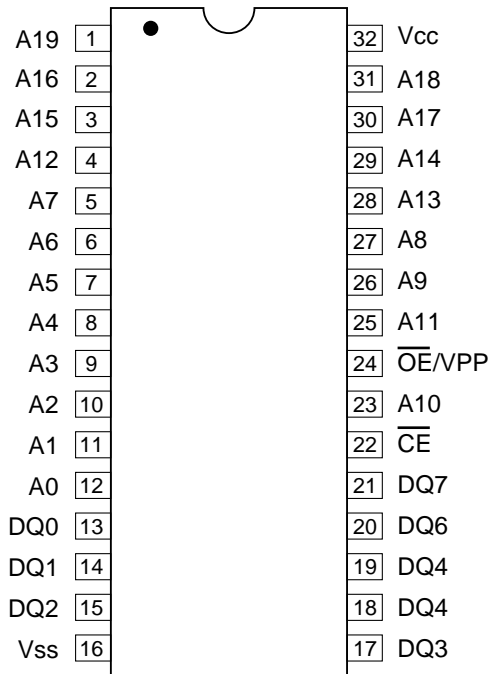

NAME	FUNCTION
A0-A19	Address Inputs
CE	Chip Enable Input
DQ0-DQ7	Data Input/Outputs
OE	Output Enable Input
Vcc	Vcc Supply Voltage
Vss	Ground

2-1-10 FIC2 (LC866232 ; Front Micom)

No	PORT NAME	ASSIGNED NAME	I/O	FUNCTION
81	P30	S1	I	SHUTTLE DATA
82	P31	S2	I	SHUTTLE DATA
83	P32	S3	I	SHUTTLE DATA
84	P33	S4	I	SHUTTLE DATA
85	P34	J1	I	JOG DATA
86	P35	J2	I	JOG DATA
87	P36	AT	I	TV TYPE
88	P37	AD	I	TV TYPE
89	VSS	+5V	-	
90	VDD	GND	-	
91	P40	REBCTL	O	SCART CONTROL
92	P41	SCONLB	O	SCART CONTROL
93	P42	-	O	
94	P43	WIDE	O	SCART CONTROL
95	P44	AMUTE3	O	SUB WOOPER MUTE
96	P45	AMUTE2	O	CENTER MUTE
97	P46	AMUTE1	O	REAR MUTE
98	P47	AMUTE0	O	FRONT MUTE
99	P50	LED	O	STANDBY LED
100	P51	ON/OFF	O	POWER ON/OFF CONTROL

No	PORT NAME	ASSIGNED NAME	I/O	FUNCTION
61	S28	SEG4	O	FLT SEGMENT CONTROL
62	S29	SEG3	O	FLT SEGMENT CONTROL
63	S30	SEG2	O	FLT SEGMENT CONTROL
64	S31	SEG1	O	FLT SEGMENT CONTROL
65	P00	KEY0	I	KEY SCAN
66	P01	KEY1	I	KEY SCAN
67	P02	KEY2	I	KEY SCAN
68	P03	GND	I	
69	P04	-	O	
70	P05	-	O	
71	P06	-	O	
72	P07	SRQ	O	Request to MAIN Micom
73	P10/S00	TXD	O	SERIAL DATA OUT
74	P11/S10	RXD	I	SERIAL DATA IN
75	P12/SCK0	SCLK	O	SERIAL CLOCK
76	P13/S01	-		
77	P14/S11	-		
78	P15/SCK1	-		
79	P16/BUZ	-		
80	P17/PWM0			

No	PORT NAME	ASSIGNED NAME	I/O	FUNCTION
31	S07/0	GRD8	O	FLT GRID CONTROL
32	S7/1	GRD7	O	FLT GRID CONTROL
33	S2/72	GRD6	O	FLT GRID CONTROL
34	S3/73	GRD5	O	FLT GRID CONTROL
35	S4/74	GRD4	O	FLT GRID CONTROL
36	S5/75	GRD3	O	FLT GRID CONTROL
37	S6/76	GRD2	O	FLT GRID CONTROL
38	S7/77	GRD1	O	FLT GRID CONTROL
39	S8/78	-	O	
40	S9/79	-	O	
41	S10/710	-	O	
42	S11/711	SEG21	O	FLT SEGMENT CONTROL
43	S12/712	SEG20	O	FLT SEGMENT CONTROL
44	S13/713	SEG19	O	FLT SEGMENT CONTROL
45	S14/714	SEG18	O	FLT SEGMENT CONTROL
46	S15/715	SEG17	O	FLT SEGMENT CONTROL
47	VDD	+5V	-	
48	VP	-28V	-	
49	S16	SEG16	O	FLT SEGMENT CONTROL
50	S17	SEG15	O	FLT SEGMENT CONTROL
51	S18	SEG14	O	FLT SEGMENT CONTROL
52	S19	SEG13	O	FLT SEGMENT CONTROL
53	S20	SEG12	O	FLT SEGMENT CONTROL
54	S21	SEG11	O	FLT SEGMENT CONTROL
55	S22	SEG10	O	FLT SEGMENT CONTROL
56	S23	SEG9	O	FLT SEGMENT CONTROL
57	S24	SEG8	O	FLT SEGMENT CONTROL
58	S25	SEG7	O	FLT SEGMENT CONTROL
59	S26	SEG6	O	FLT SEGMENT CONTROL
60	S27	SEG5	O	FLT SEGMENT CONTROL

No	PORT NAME	ASSIGNED NAME	I/O	FUNCTION
1	P52	MIRST	O	Front end reset
2	PVMT1	-	-	
3	P20	DFS	O	D/A Control
4	P21	DEW00	O	D/A Control
5	P22	DEW01	O	D/A Control
6	P23	DARST	O	D/A Control
7	P24	DIF0	O	D/A Control
8	P25	DIF1	O	D/A Control
9	P26	DIF2	O	D/A Control
10	P27	DARST1	O	D/A Control
11	TEST1	-	-	
12	*RES	-	I	Reset
13	XT1	GND	-	Low frequency OSC. in
14	XT2	-	-	Low frequency OSC. out
15	VSS	GND	-	
16	CF1	-	-	High frequency OSC. in
17	CF2	-	-	High frequency OSC. out
18	VDD	VDD	-	
19	AN0/P80	ECHO_VR	I	ECHO volume A/D input
20	AN1/P81	MIC_DET	I	MIC detect
21	AN2/P82	-	I	
22	AN3/P83	MODE0	I	HARDWARE MODE SELECT
23	AN4/P84	MODE1	I	HARDWARE MODE SELECT
24	AN5/P85	MODE2	I	HARDWARE MODE SELECT
25	AN6/P86	MODE3	I	HARDWARE MODE SELECT
26	AN7/P87	MODE4	I	HARDWARE MODE SELECT
27	P70/INT0	RRO	I	Request to front micom
28	P71/INT1	-	I	
29	P72/INT2	-	I	
30	P73/INT3	REMOCON	I	REMOCON data in

MEMO

3. Product Specifications

GENERAL	Power Requirements	AC 120V, 60Hz	
	Power Consumption	18W	
	Weight	7.5lbs	
	Dimensions	W 16.9 in X D 11.0 in X H 3.5 in	
	Operating Temperature Range	+41°F ~ +95°F	
	Operating Humidity Range	10% to 75%	
DISC	DVD (Digital Versatile Disc)	Reading Speed : 11.45 ft/sec. Approx. Play Time (Single Sided, Single Layer Disc) : 135 min.	
	CD : 5 inches (Compact Disc)	Reading Speed : 3.9 to 4.6 ft/sec. Maximum Play Time : 74min.	
	CD : 3 1/2 inches (Compact Disc)	Reading Speed : 3.9 to 4.6 ft/sec. Maximum Play Time : 20min.	
	VCD : 5 inches	Reading Speed : 3.9 to 4.6 ft/sec. Maximum Play Time : 74min. (Video + Audio)	
	Video Output	Component Video	1 channel : 1.0Vp-p (75ohm load)
		Component Video	Y : 1.0Vp-p (75ohm load)
Pr : 0.70Vp-p (75ohm load)			
Pb : 0.70Vp-p (75ohm load)			
S-Video	Luminance Signal : 1Vp-p (75ohm load) Color Signal : 0.286Vp-p (75ohm load)		
Audio Output	2 channel	L, R	
	Output Level	Analog : 2Vrms (1KHz)	
		Digital : 0.50Vp-p	
	* Frequency Response	48KHz Sampling : 4Hz to 22 KHz	
		96KHz Sampling : 4Hz to 44KHz	
	* S/N Ratio	110dB	
	* Dynamic Range	96dB	
* Total Harmonic Distortion	0.003%		

* : Nominal specification

MEMO

4. Operating Instructions

Description-Front Panel

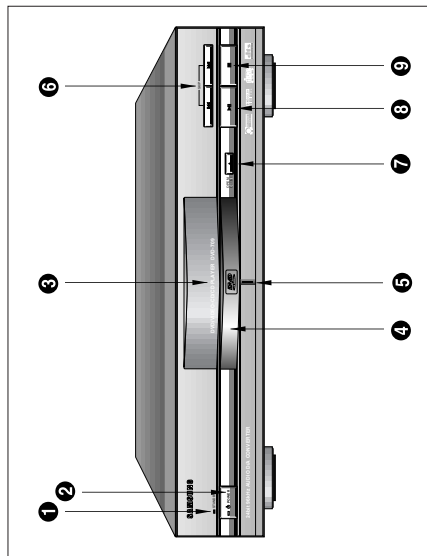

Front Panel Controls

- 1 **STANDBY LAMP**
 - When the unit is first plugged in, the indicator lights. When power is pressed on, the lamp goes out.
- 2 **POWER**
 - Use to turn the power on and off.
- 3 **DISPLAY** (See below)
 - Operation indicators are displayed here.
- 4 **DISC TRAY**
 - Press OPEN/CLOSE to open and close the disc tray.
- 5 **GREEN LAMP**
- 6 **SKIP/SEARCH**
 - Use to skip or search a scene or music.
- 7 **OPEN/CLOSE**
 - Press to open and close the disc tray.
- 8 **PLAY/PAUSE**
 - Begin or pause disc play.
- 9 **STOP**
 - Stops disc play.

Front Display

- 1 **DISC OPERATION ROTARY INDICATOR**
- 2 **OPERATION INDICATOR**
- 3 **DISC TYPE INDICATOR**
- 4 **TRACK INDICATOR**
- 5 **3D SOUND INDICATOR**
- 6 **ANGLE INDICATOR**
- 7 **CHAPTER INDICATOR**
- 8 **REPEAT INDICATOR**
- 9 **CHAPTER, TITLE, TRACK & MESSAGE INDICATOR**
- 10 **ALL REPEAT INDICATOR**
- 11 **A-B REPEAT INDICATOR**
- 12 **PROGRAM PLAY INDICATOR**
- 13 **MPEG INDICATOR**
- 14 **DOLBY DIGITAL INDICATOR**
- 15 **LINEAR PCM INDICATOR**
- 16 **DTS INDICATOR**

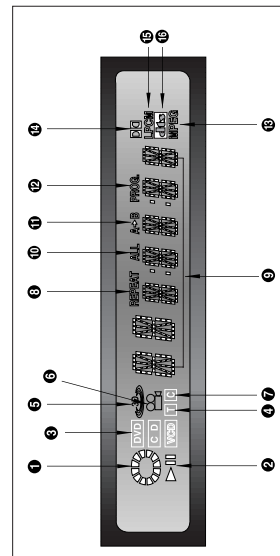

Description-Rear Panel

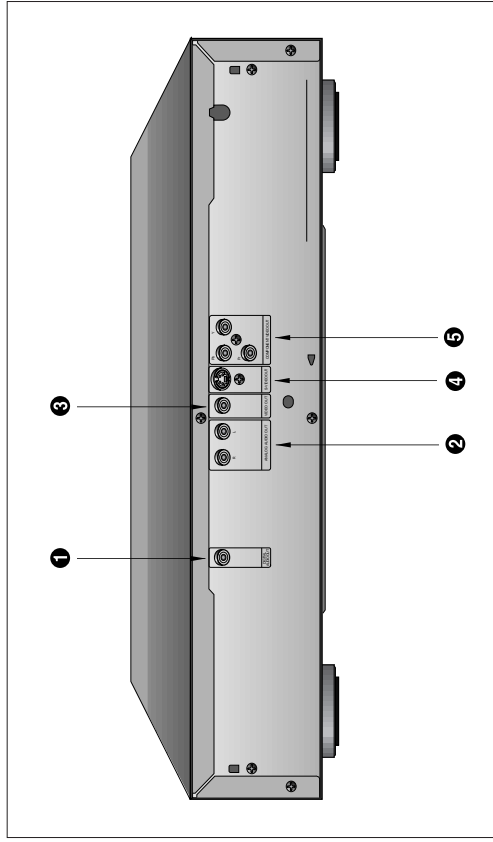

Rear Panel

- 1 **DIGITAL AUDIO OUT JACK**
 - Use a coaxial digital cable to connect to an A/V Amplifier that contains a Dolby Digital decoder or DTS decoder.
- 2 **ANALOG AUDIO OUT JACKS**
 - Connect to the Audio input jacks of your television, audio/video receiver, or VCR.
- 3 **VIDEO OUT JACK**
 - Use a video cable to connect this jack to the Video input on your television.
- 4 **S-VIDEO OUT JACK**
 - Use the S-video cable to connect this jack to the S-Video jack on your television for a higher quality picture.
- 5 **COMPONENT VIDEO OUT JACKS**
 - Use these jacks if you have a TV with component video in jacks. These jacks provide Pr, Pb and Y video. Along with S-Video, Component Video provides the best picture quality.

A Tour of the Remote Control

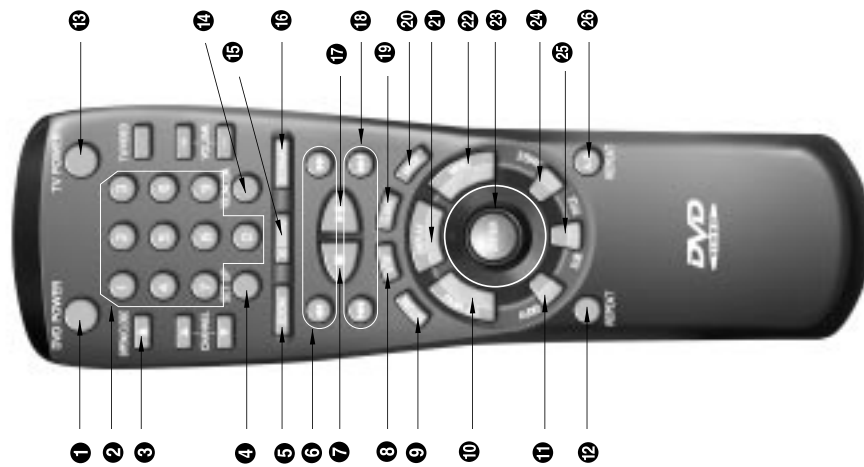

DVD Function Buttons

- 1 **DVD POWER Button**
- 2 **NUMBER Buttons**
- 3 **OPEN/CLOSE Button**
 - Brings up the DVD player's Setup menu.
- 4 **SETUP Button**
- 5 **ZOOM Button**
- 6 **SEARCH Buttons**
 - Allows you to search forward/backward through a disc.
- 7 **STOP Button**
- 8 **STEP Button**
 - Advances playback one frame at a time.
- 9 **RETURN Button**
 - Returns to a previous menu.
- 10 **TOP MENU Button**
 - Accesses a music or video display directly.
- 11 **AUDIO Button**
 - Use this button to access various audio functions on a disc.
- 12 **REPEAT Button**
 - Allows you to repeat play a title, chapter, track, or disc.
- 13 **TV POWER Button**
 - Use to set the remote to control a compatible TV.
- 14 **VOLUME CON. Button**
 - To control the master volume of the player.
- 15 **3D SOUND Button**
- 16 **BOOKMARK Button**
- 17 **PLAY/PAUSE Button**
 - Begin/Pause disc play.
- 18 **SKIP Buttons**
 - Use to skip the title, chapter, or track.
- 19 **CLEAR Button**
 - Use to remove menus or status displays from the screen.
- 20 **MODE Button**
 - Allows you to program a specific order.
- 21 **DISPLAY Button**
 - Displays the current disc mode.
- 22 **MENU Button**
 - Brings up the Disc menu.
- 23 **ENTER/DIRECTION Button (UP/DOWN or LEFT/RIGHT Button)**
 - This button functions as a toggle switch.
- 24 **ANGLE Button**
 - Use to access various camera angles on a DVD.
- 25 **SUBTITLE Button**
- 26 **A-B REPEAT Button**
 - Use to mark a segment to repeat between A and B.

A Tour of the Remote Control (Cont'd)

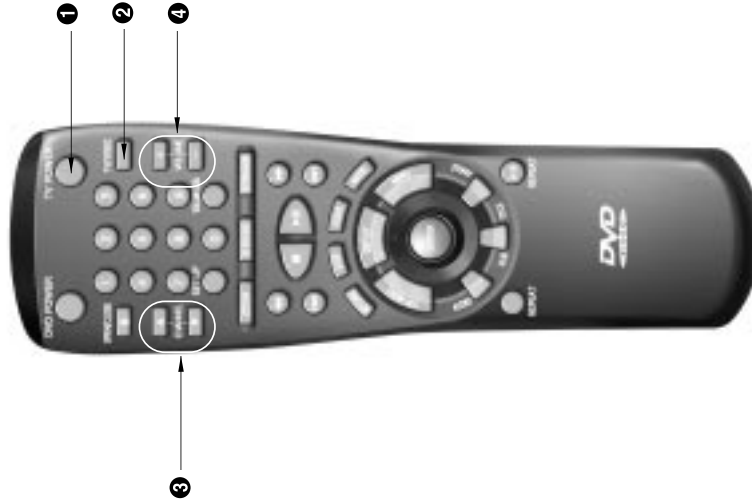

TV Function Buttons

- 1 **TV POWER Button**
- 2 **TV/VIDEO Selection Button**
- 3 **CHANNEL UP/DOWN Buttons**
- 4 **VOLUME UP/DOWN Buttons**

Install Batteries in the Remote

1. Open the battery cover on the back of the remote.
2. Insert two AA batteries. Make sure that the polarities (+ and -) are aligned correctly.
3. Replace the battery cover.

If remote doesn't operate properly:

- Check the polarity + - of the batteries (Dry-Cell)
- Check if the batteries are drained.
- Check if remote sensor is blocked by obstacles.
- Check if there is any fluorescent lighting nearby.

NOTE This icon indicates an invalid button press.

Choosing a Connection

The following show examples of connections commonly used to connect the DVD player with a TV and other components.

Before Connecting the DVD Player

- Always turn off the DVD player, TV, and other components before you connect or disconnect any cables.
- Refer to owner's manual of the components you are connecting for more information on those particular components.

Connecting to a TV (For Video)

- **Method 1**
DVD Player + TV with Video Input Jack
- **Method 2**
DVD Player + TV with S-Video Input Jack
- **Method 3**
DVD Player + TV with Component Video Jacks

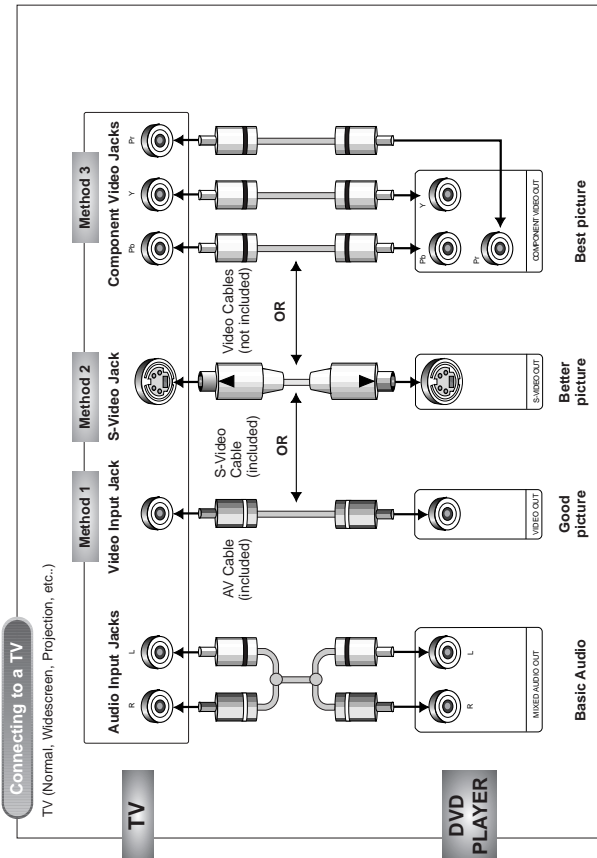

Choosing a Connection (Cont'd)

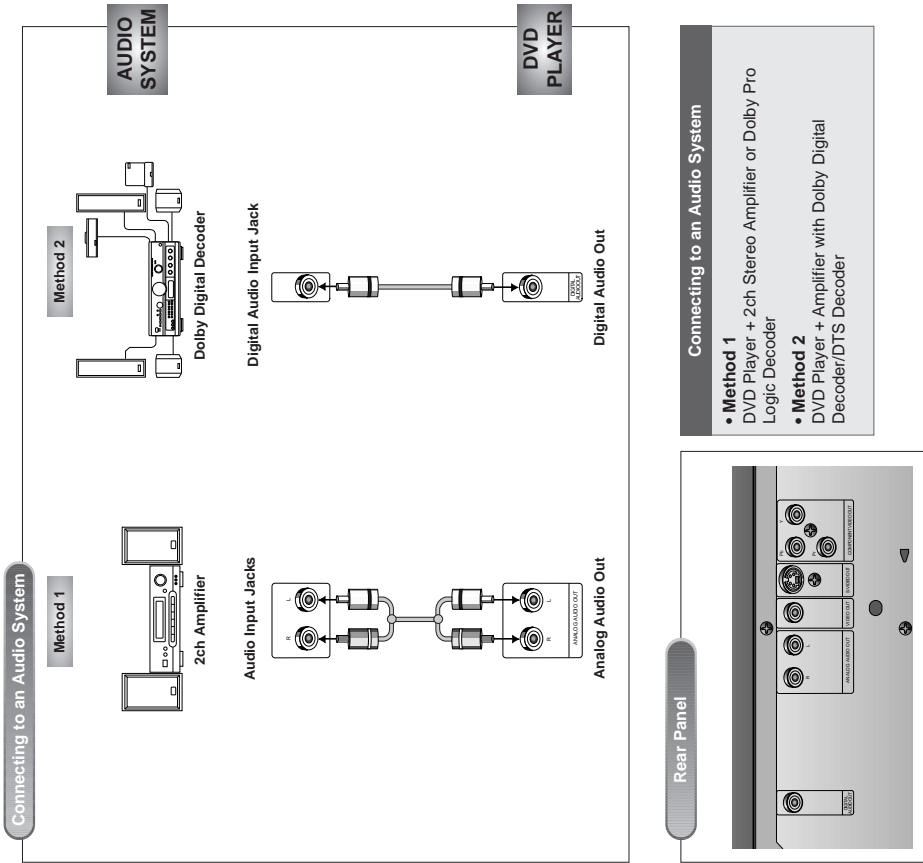

MEMO

5. Disassembly and Reassembly

5-1 Cabinet and PCB

5-1-1 Door-Tray Removal

- 1) Supply power and open Tray ❶.
- 2) Disassemble the Door-Tray ❷ in direction of arrow "A".
- 3) Close Tray ❶ and power off.

Note : If Tray ❶ doesn't open, insert a Screw driver ❹ into the Emergency hole ❸ (as shown in detailed drawing) and then turn it in the direction of arrow "B". Open Tray manually.

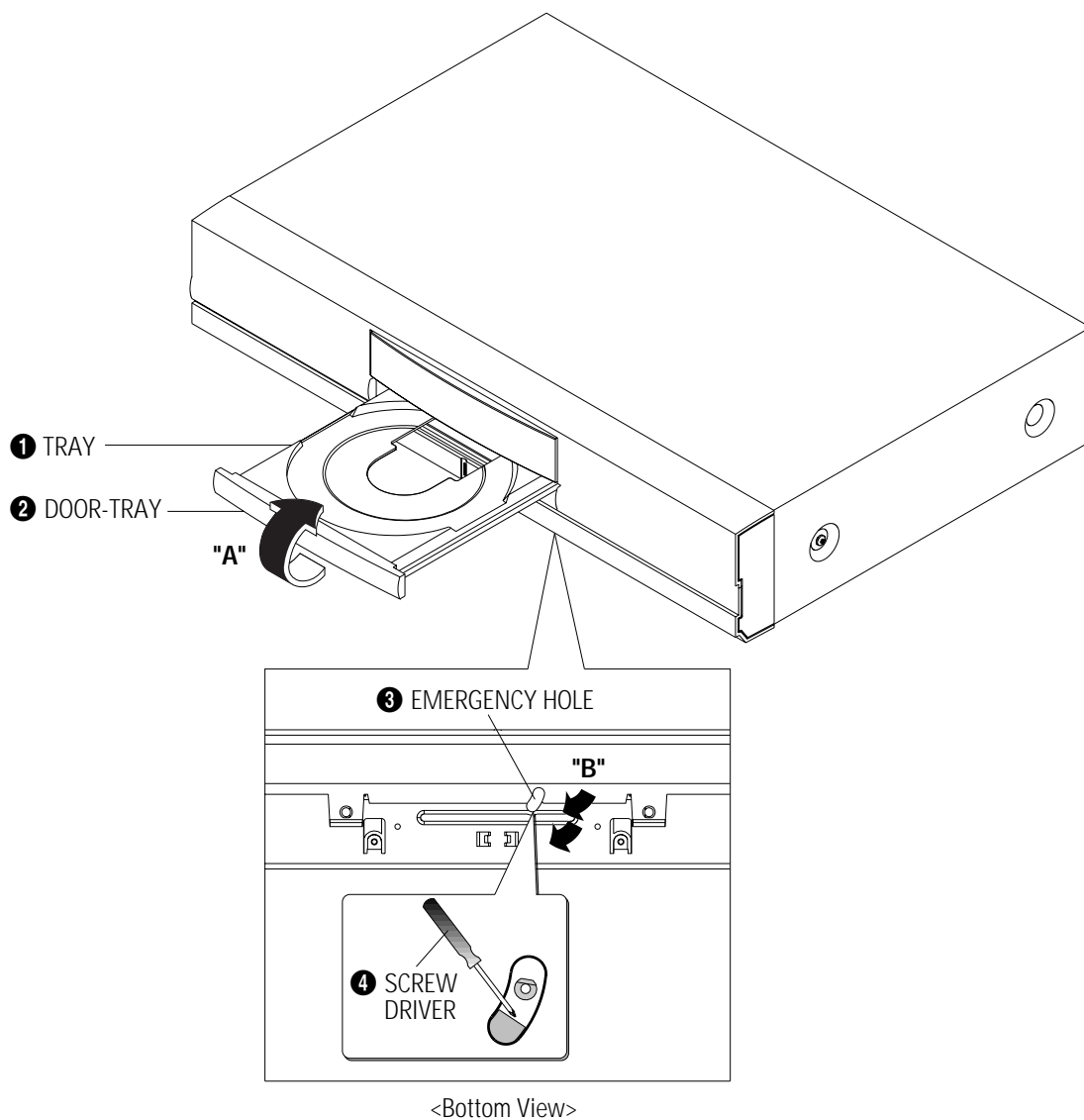

Fig. 5-1 Door-Tray Removal

5-1-2 Top Cabinet Removal

- 1) Remove 3 Screws ❶ on the back Top Cabinet.
- 2) Remove 2 Screws ❷, ❸ on the left and right side.
- 3) Lift up the Top Cabinet in direction of arrow.

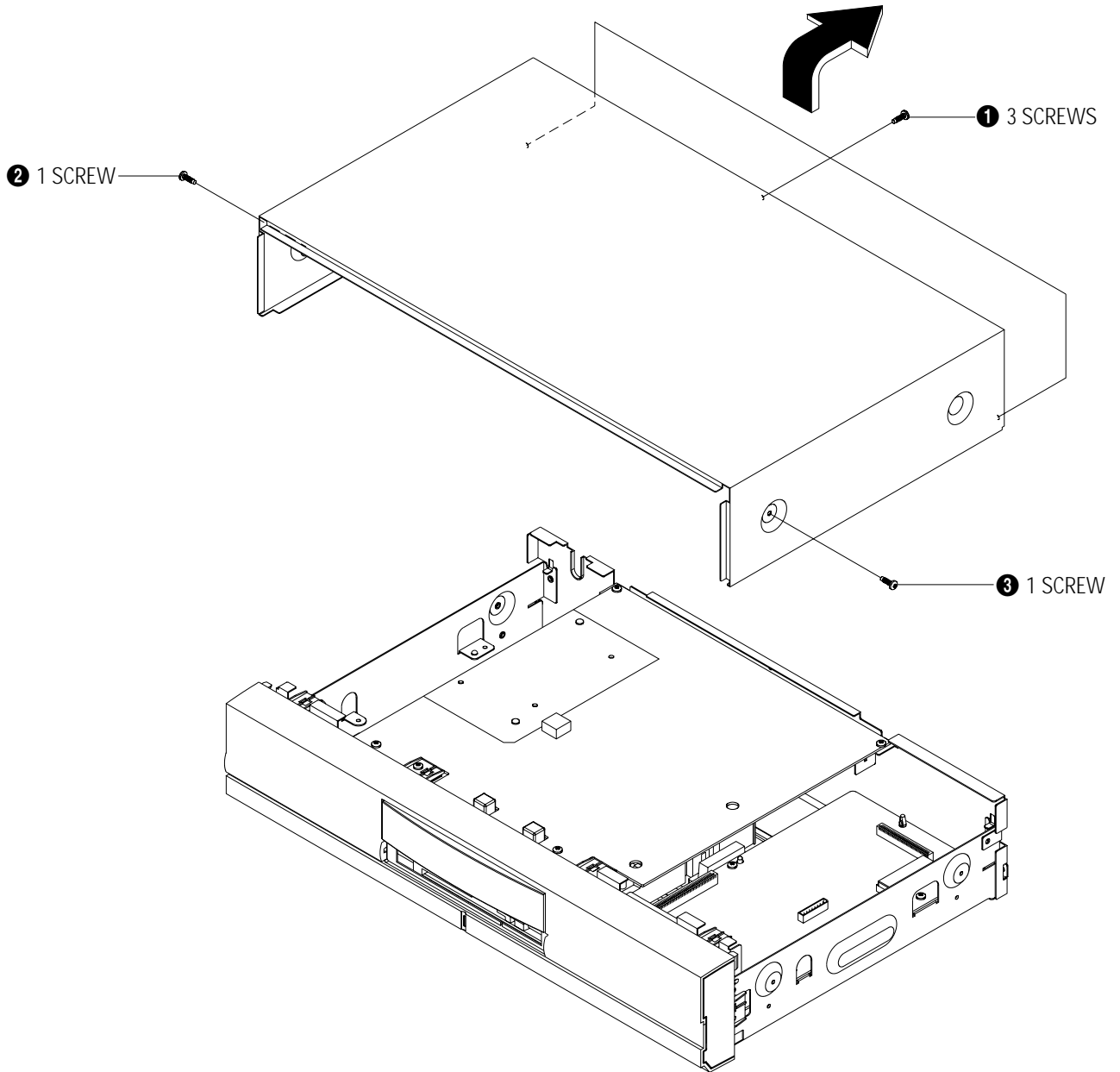

Fig. 5-2 Top Cabinet Removal

5-1-3 Ass'y Front-Panel, Power PCB, Play PCB Removal

- 1) Remove 2 Screws **1** and Ass'y Front Panel **2**.
- 2) Remove 2 Screws **3** and Power PCB **4**.
- 3) Remove 3 Screws **5** and Play PCB **6**.

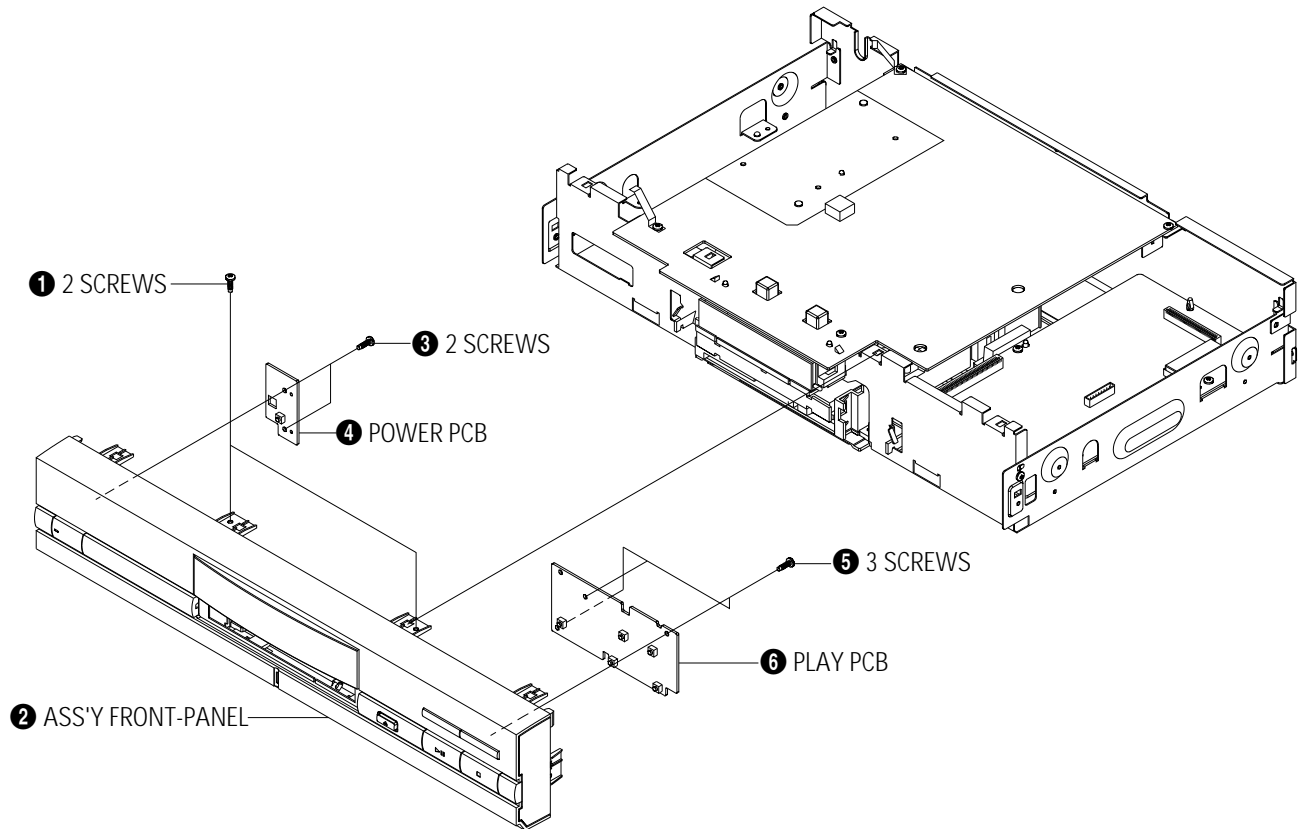

Fig. 5-3 Ass'y Front-Panel, Power PCB, Play PCB Removal

5-1-4 Main PCB, Jack PCB Removal

- 1) Remove 4 Screws **1** and 1 Screw **2**.
- 2) Lift up the Jack PCB **3**.
- 3) Remove 3 Screws **4** and lift up the Main PCB **5**.

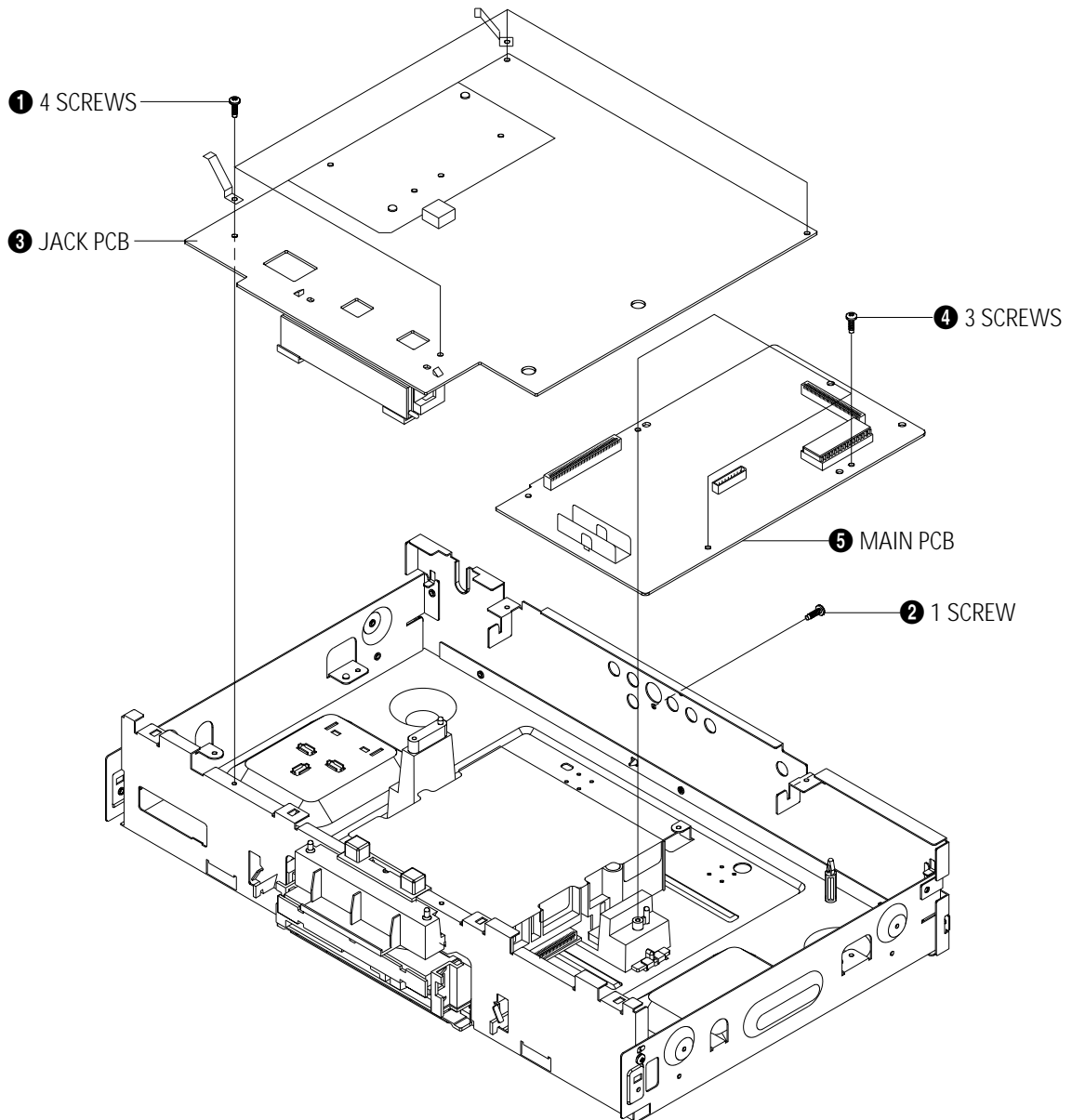

Fig. 5-4 Main PCB, Jack PCB Removal

5-1-5 Ass'y Deck Removal

1) Remove 4 Screws ❶ from the Ass'y Deck and lift it up.

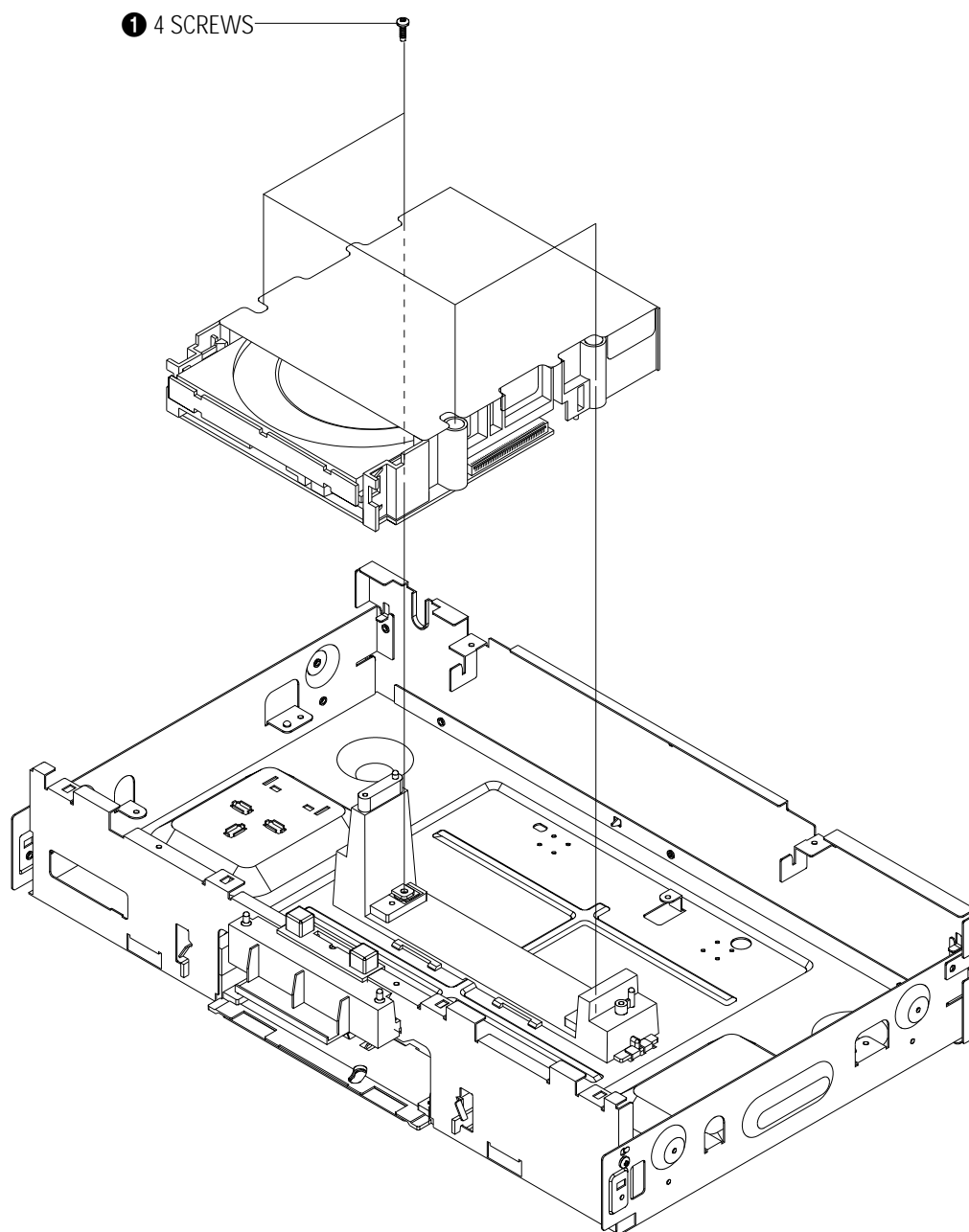

Fig. 5-5 Ass'y Deck Removal

5-2 PCB Location

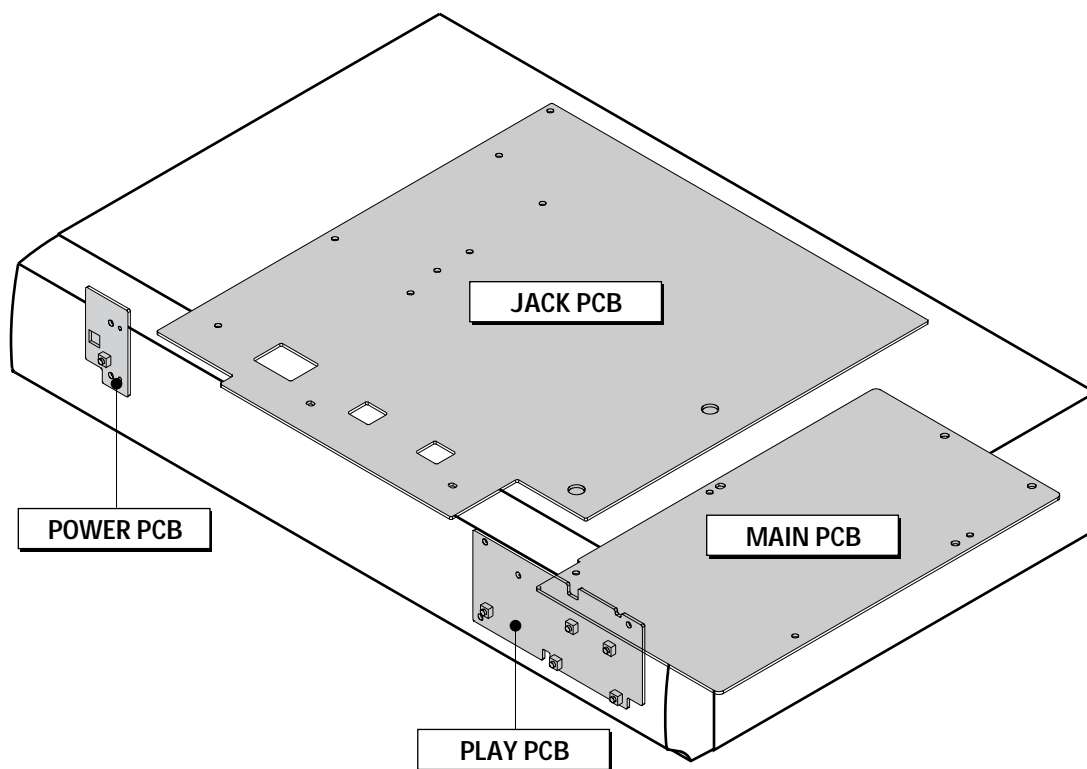
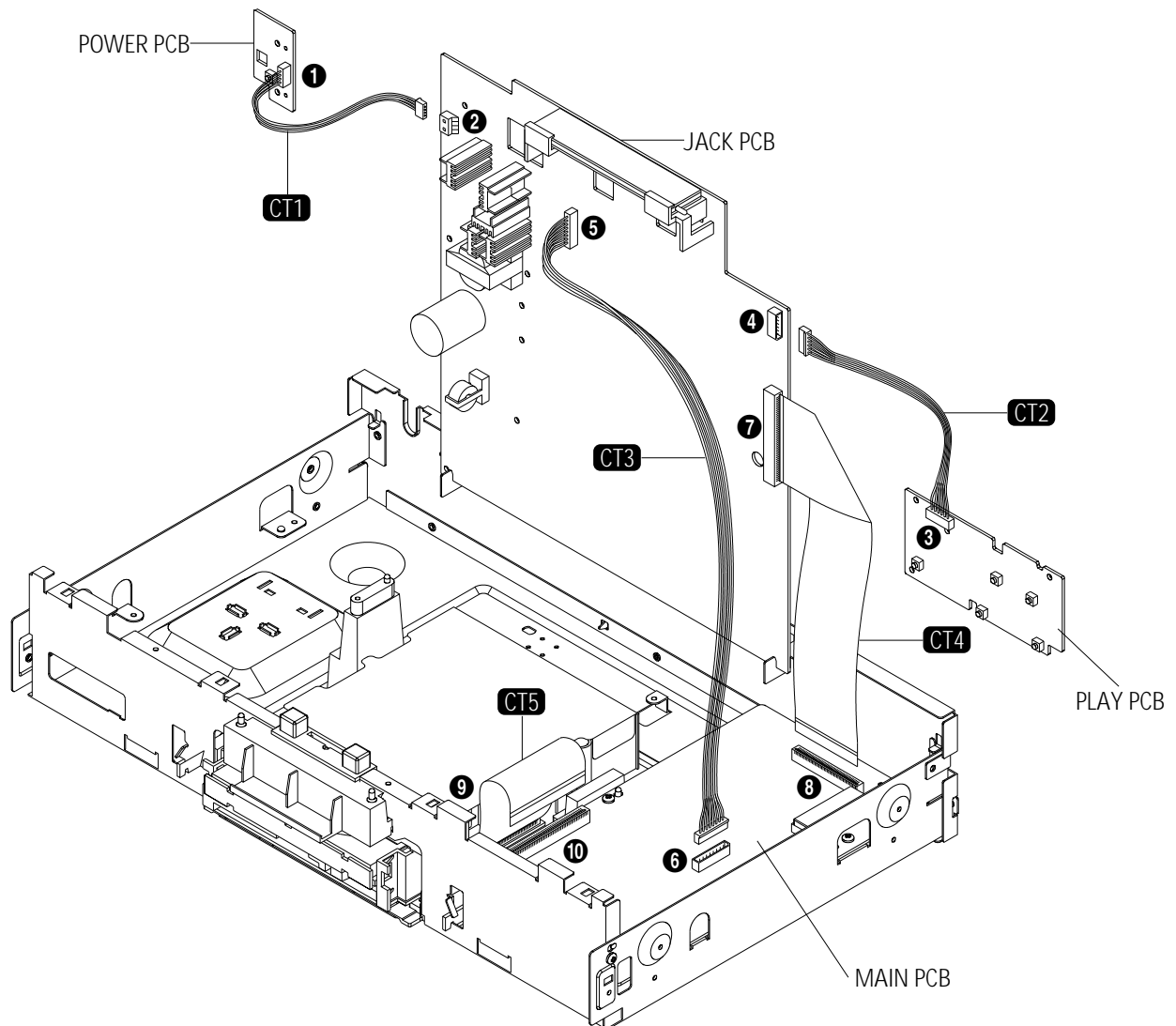

Fig. 5-6 PCB Location

5-3 Connector Diagram



NO.	CONNECTOR NO.	DIRECTION	CONNECTOR NO.
1	KCN2	POWER PCB ← CT1 → JACK PCB	CN18
2	CN18	JACK PCB ← CT1 → POWER PCB	KCN2
3	CON22	PLAY PCB ← CT2 → JACK PCB	CN16
4	CN16	JACK PCB ← CT2 → PLAY PCB	CON22
5	CN12	JACK PCB ← CT3 → MAIN PCB	CN7
6	CN7	MAIN PCB ← CT3 → JACK PCB	CN12
7	CN11	JACK PCB ← CT4 → MAIN PCB	CN8
8	CN8	MAIN PCB ← CT4 → JACK PCB	CN11
9	CN5	DECK PCB ← CT5 → MAIN PCB	CN6
10	CN6	MAIN PCB ← CT5 → DECK PCB	CN5

Fig. 5-7 Connector Diagram

5-4 Deck

5-4-1 Tray Removal

- 1) Remove 2 Screws ❶ and lift up the Cover Sheet ❷, Ass'y-Deck Clamper ❸.
- 2) Insert a Screw driver ❺ into Emergency hole ❹ and push it in the direction of arrow "A".
When the Tray ❻ comes out a little, pull it in the direction of arrow "B" by hand.
- 3) Pull the Tray ❻ to disassemble, while simultaneously pushing the Hook ❼, ❽ in direction of arrow "A", "B".

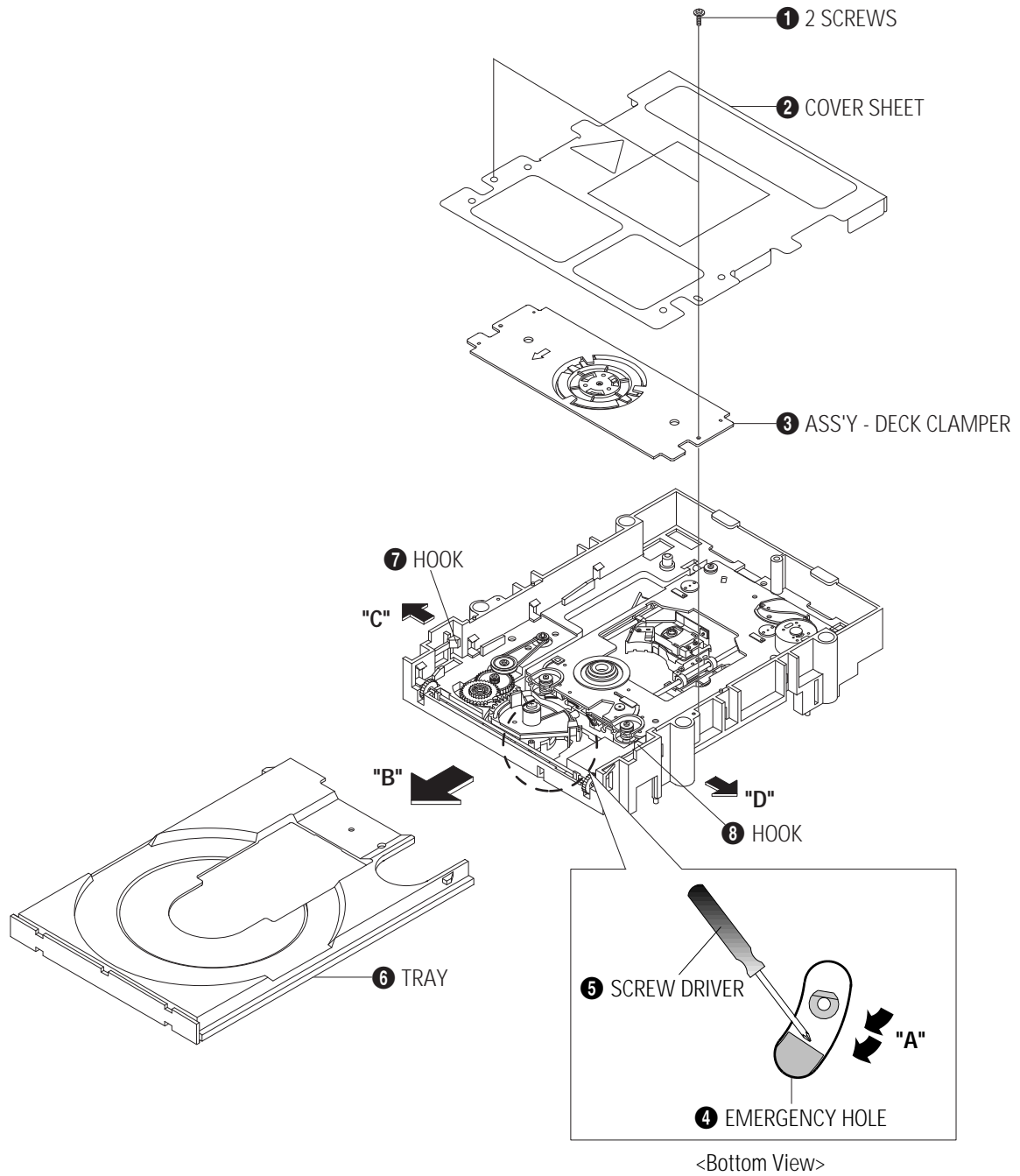

Fig. 5-8 Tray Removal

5-4-2 Ass'y-Deck Sub Removal

- 1) Remove 2 Screws ❶ and disassemble the Ass'y-PCB deck ❷.
- 2) Disassemble the Ass'y-Deck Sub ❸ in direction of arrow "B", while simultaneously pushing the Hook ❹ in direction of arrow "A".

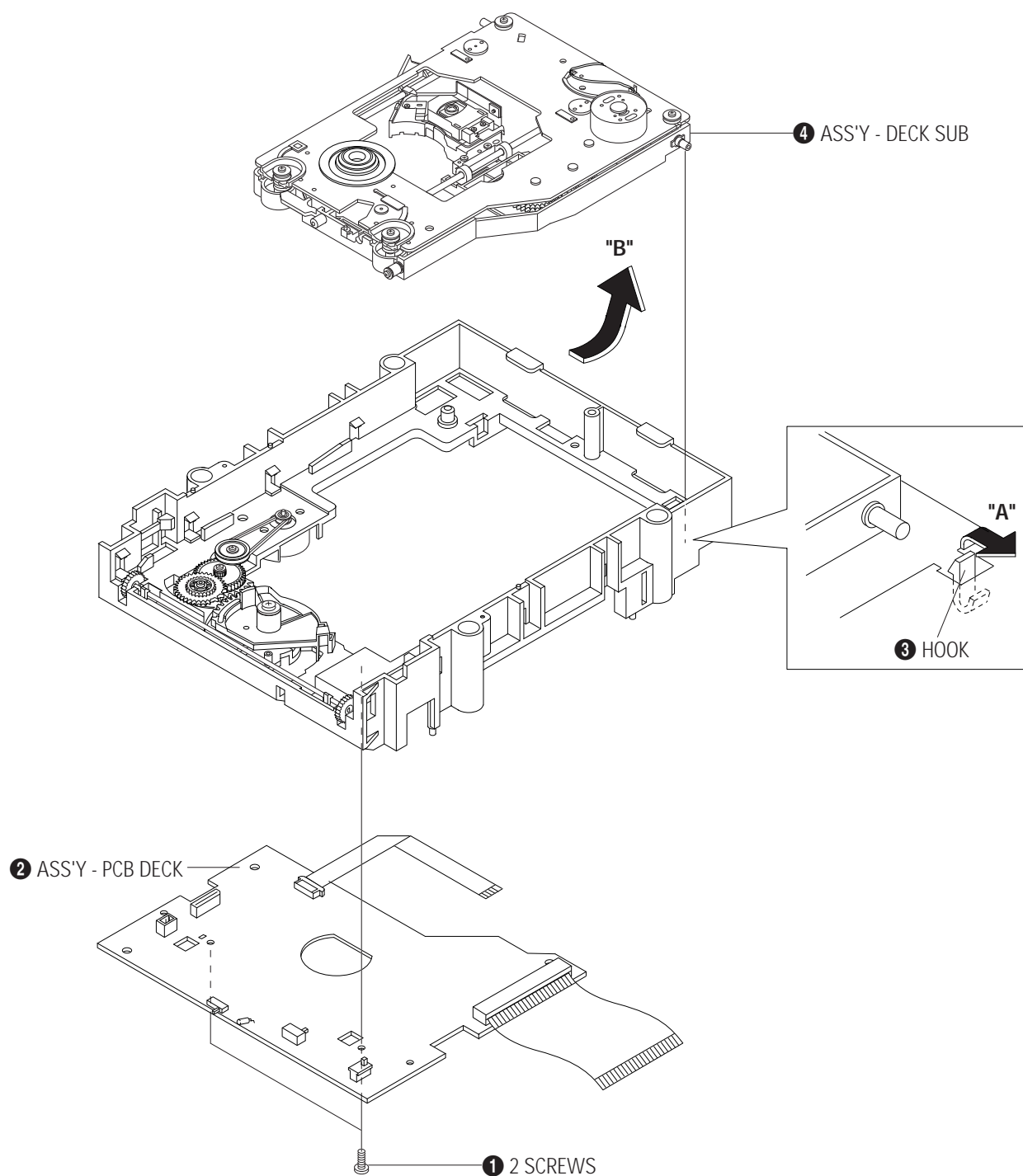

Fig. 5-9 Ass'y-Deck Sub Removal

5-4-3 Chassis-Main Parts Removal

- 1) Lift up the Gear-Tray ❶, remove 1 Screw ❷ and lift up the Gear-Cam Center ❸.
- 2) Lift up the Belt-Pulley ❹, remove 1 Screw ❺ and lift up the Pulley-Gear ❻.
- 3) Remove 1 Screw ❼ and lift up the Gear-Tray A ❽ and Gear-Cam Sub ❾.
- 4) Remove 2 Screws ❿ and disassemble the Ass'y-Motor Load ❾.
- 5) Remove 1 Screw ❿ and disassemble the Lever-Open S/W ❿.
- 6) Lift up the Shaft-Syncro ❿ and remove the 2 Gear-Syncro ❿ in both directions.

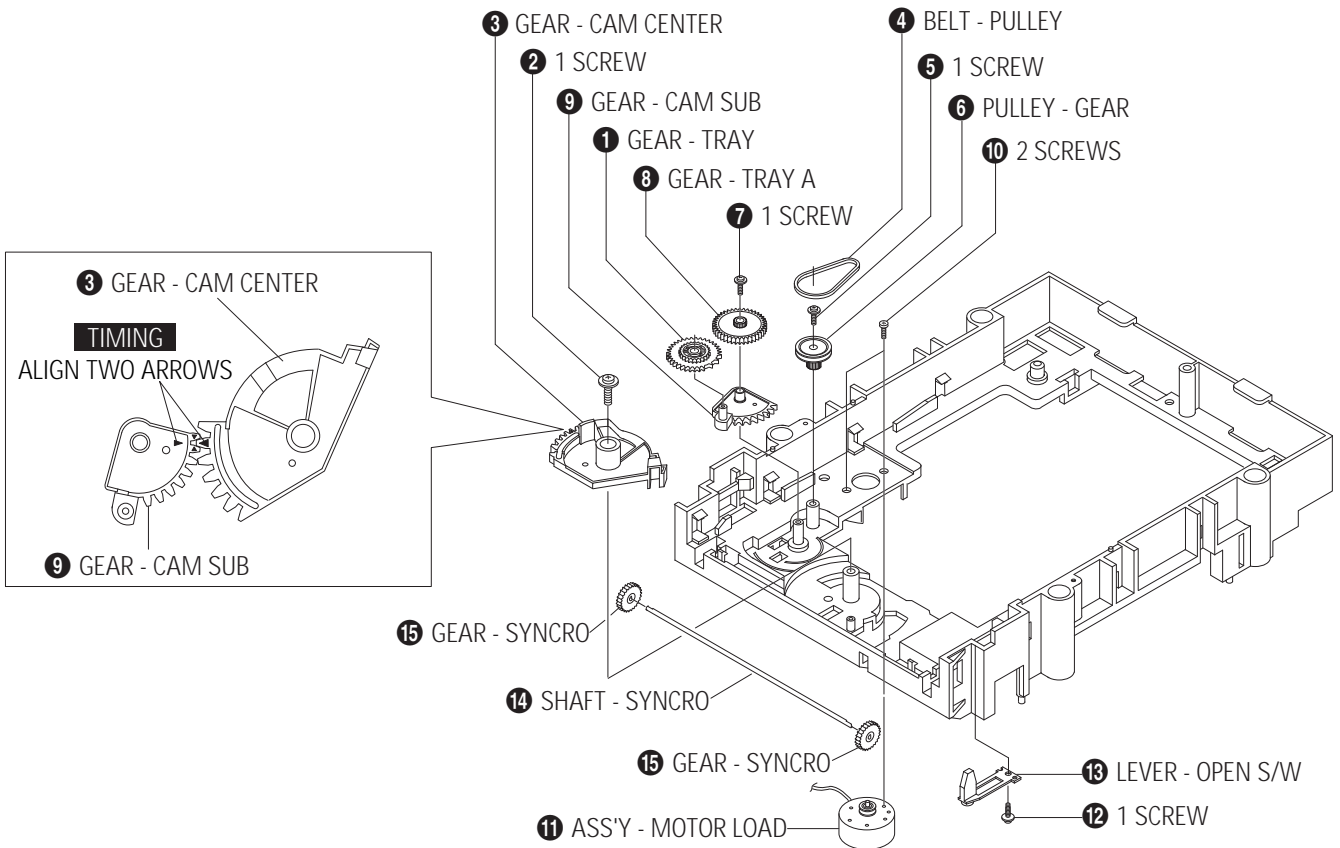

Fig. 5-10 Chassis-Main Parts Removal

5-4-4 Ass'y-Brkt Deck Removal

- 1) Remove 4 Screws ❶.
- 2) Lift up the Ass'y-Brkt Deck ❷.

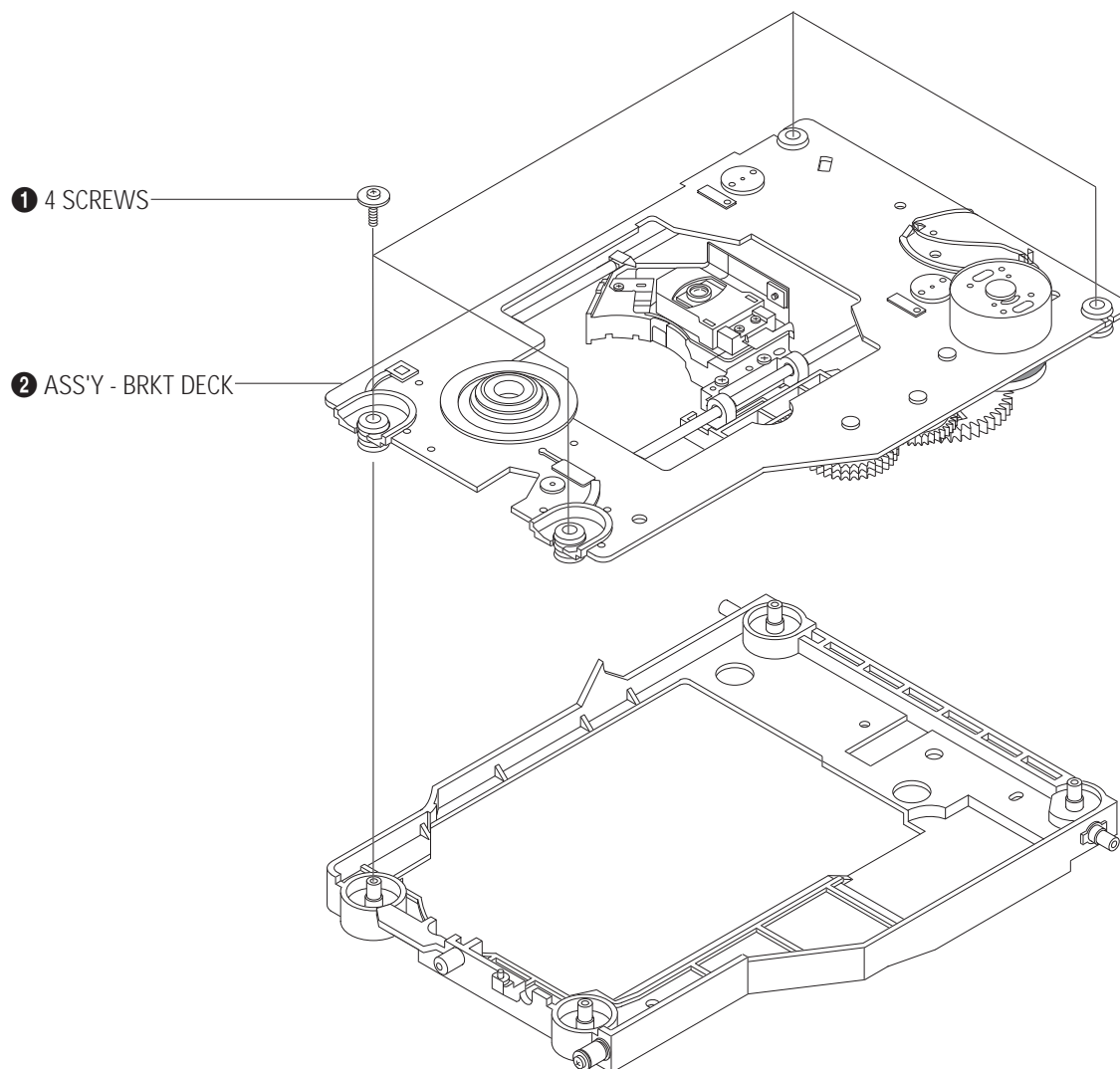

Fig. 5-11 Ass'y-Brkt Deck Removal

5-4-5 Ass'y-Deck Parts Removal

- 1) Remove 3 Screws ❶ and disassemble 3 Holder-Cams ❷.
- 2) Disassemble the Rack-Slide ❸ and Ass'y-Pickup ❹, 2 Screws ❺ while simultaneously removing the Shaft-P/U ❻.
- 3) Remove 3 Screws ❼ and disassemble the Ass'y-Motor Spindle ❽.
- 4) Remove the Washer-Plain ❾ and disassemble the Ass'y-Gear Feed AU/AL ❿.
- 5) Remove the Washer-Plain ⓫ and disassemble the Gear-Feed B ⓬.
- 6) Remove the Washer-Plain ⓭ and disassemble the Ass'y-Gear Feed CU/CL ⓮.

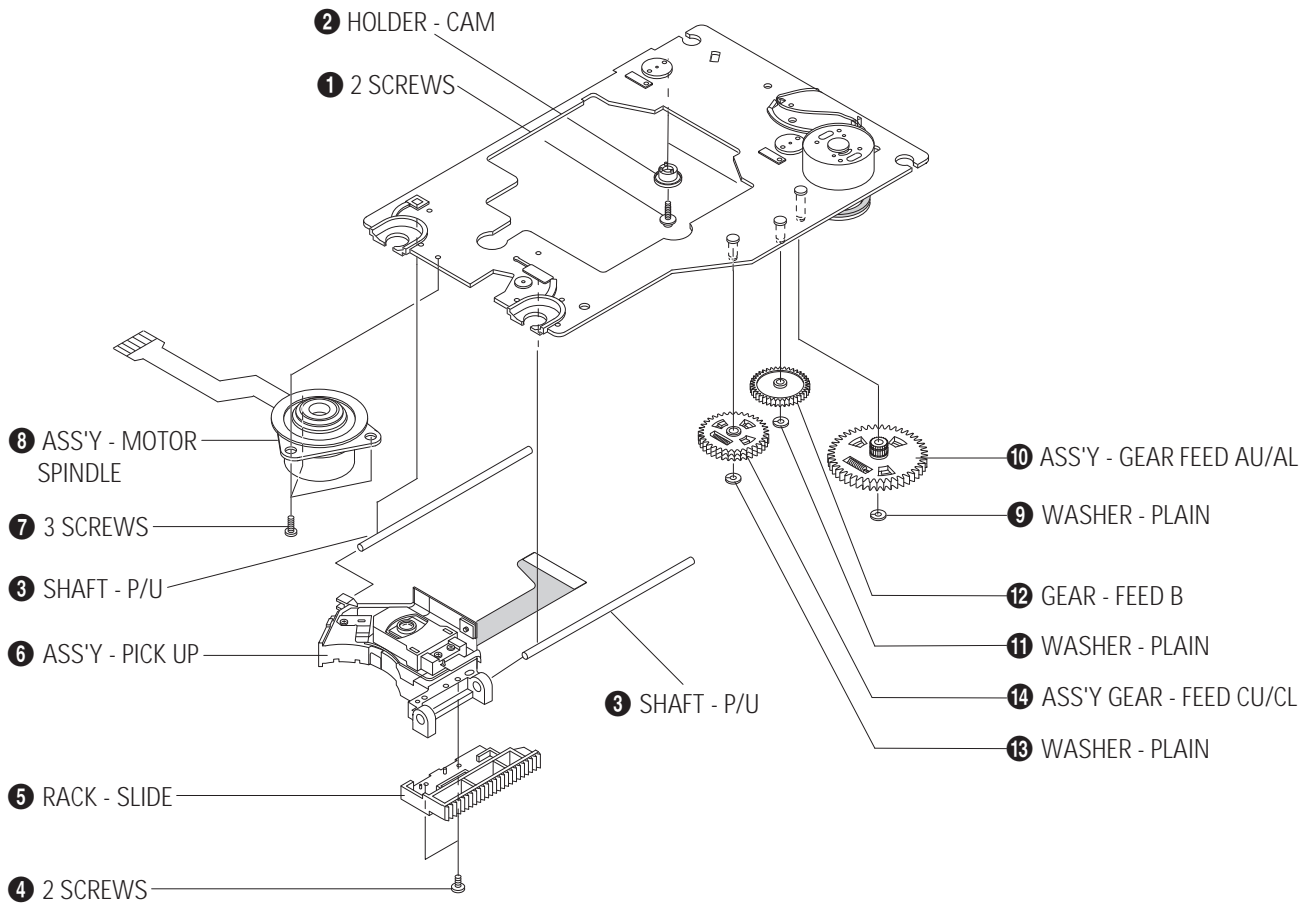

Fig. 5-12 Ass'y- Deck Parts Removal

6. Circuit Descriptions

6-1 S.M.P.S.

6-1-1 Comparison between Linear Power Supply and S.M.P.S.

6-1-1 (a) Linear

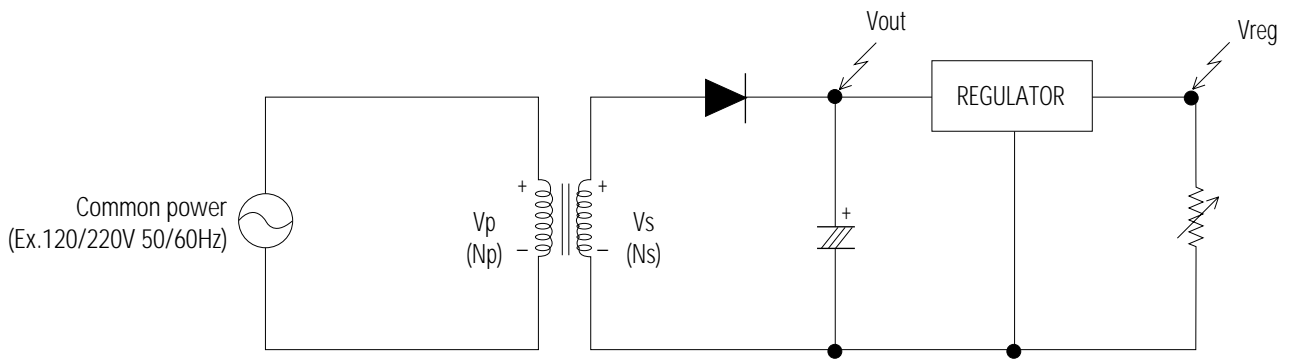

Fig. 6-1 Linear Power Supply

◆ Waveform/Description

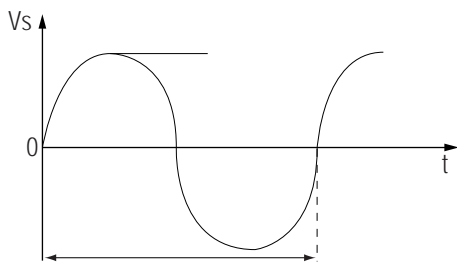

Fig. 6-2

Input : Common power to transformer (V_p).

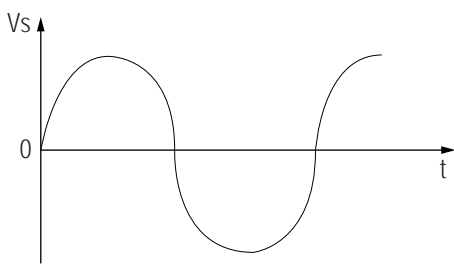

Fig. 6-3

The output V_s of transformer is determined by the ratio of 1st N_p and 2nd N_s .
 $V_s = (N_s / N_p) \times V_p$

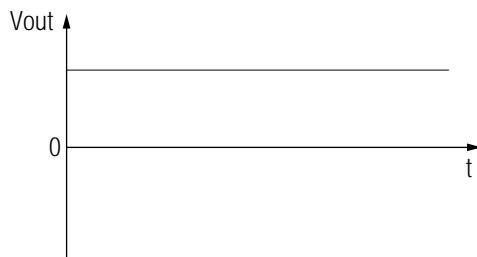

Fig. 6-4

V_{out} is output (DC) by diode and condensor.

◆ Advantages and disadvantages of linear power supply

- 1) Advantages : Little noise because the output waveform of transformer is sine wave.
- 2) Disadvantages :
 - ❶ Additional margin is required because V_s is changed (depending on power source). (The regulator loss is caused by margin design).
 - ❷ Greater core size and condensor capacity are needed, because the transformer works on a single power frequency.

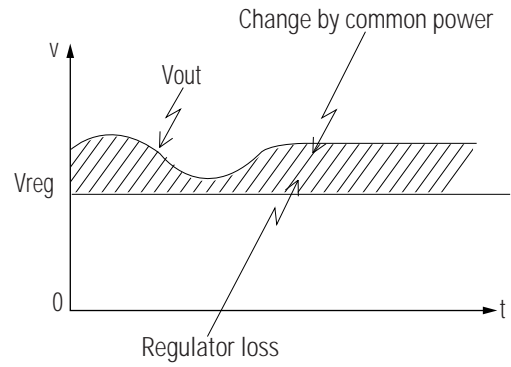

Fig. 6-5

6-1-1 (b) S.M.P.S. (Pulse width modulation method)

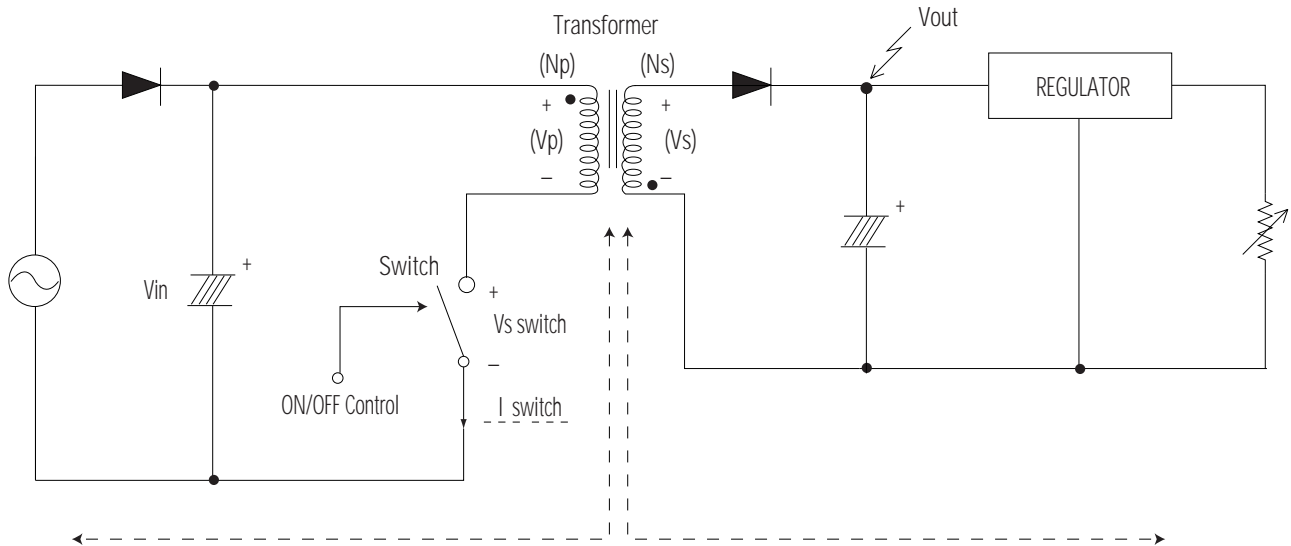

Fig. 6-6

◆ Terms

- 1) 1st : Common power input to 1st winding.
- 2) 2nd : Circuit following output winding of transformer.
- 3) f (Frequency) : Switching frequency (T : Switching cycle)
- 4) Duty : $(T_{on}/T) \times 100$

6-1-2 Circuit description (FLY-Back PWM (Plise Width Modulation) Control)

6-1-2 (a) AC Power Rectification/Smoothing Terminal

- 1) PD01,PD02,PD03,PD04 : Convert AC power to DC(Wave rectification)
- 2) PE3 : Smooth the voltage converted to DC(Refer to VIN of Fig. 6-7)
- 3) PC01, PC02, PC10, PC11, PC12, PC13, PL01, PL02, PL03 : Noise removal at power input/output
- 4) PVA1 : SMPS protection at power surge input (PVA1 pattern open is to remove noise)
- 5) PR10 : Rush current limit resistance at the moment of power cord insertion.
 - ❶ Rush current = (AC input voltage x 1.414 - Diode drop voltage) / Pattern resistance + PL02,01 resistance + PC10 resistance + PR10) (AC230V based : approx. 26A)
 - ❷ Without PR10, the bridge diode might be damaged as the rush current increases.

6-1-2 (b) SNUBBER Circuit : PR15, PR16, PC04, PC05, PD11, PR17

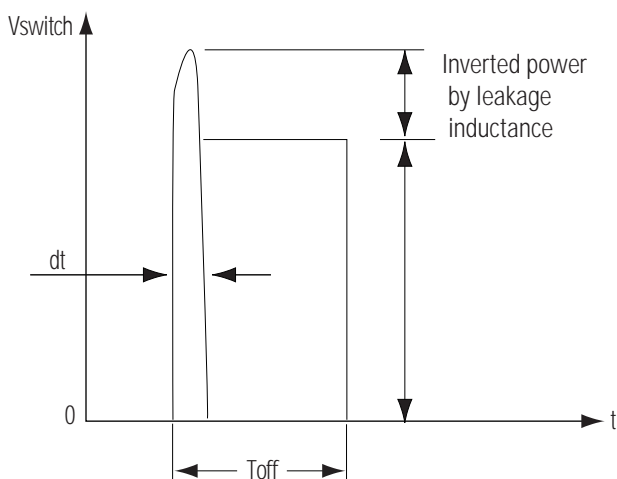

Fig. 6-7

- 1) Prevent residual high voltage at the terminals of switch during switch off/Suppress noise. High inverted power occurs at switch (PIC1) off, because of the 1st winding of transformer : ($V = LI \times di/dt$. LI : Leakage Induction) A very high residual voltage exists on both terminals of PIC1 because dt is a very short.
- 2) SNUBBER circuit protects PIC1 from damage through leakage voltage suppression by RC, (Charges the leakage voltage to PD11 and PC04, and discharges to PR15 and PR16).
- 3) PC05, PR17 : For noise removal

6-1-2 (c) PIC1 Vcc circuit

- 1) PR11, PR12, PR13, PR14 : PIC1 driving resistance (PIC1 works through driving resistance at power cord in)
- 2) PIC1 Vcc : PR18, PD12, PE6
 - ❶ Use the output of transformer as Vcc, because the current starts to flow into transformer while PIC1 is active.
 - ❷ Rectify to PD12 and smooth to PE6.
 - ❸ Use the output of transformer as PIC1 Vcc : The loads are different before and after PIC1 driving. (Vcc of PIC1 decreases below OFF voltage, using only the resistance due to load increase after PIC1 driving.)

6-1-2 (d) Feedback Control Circuit

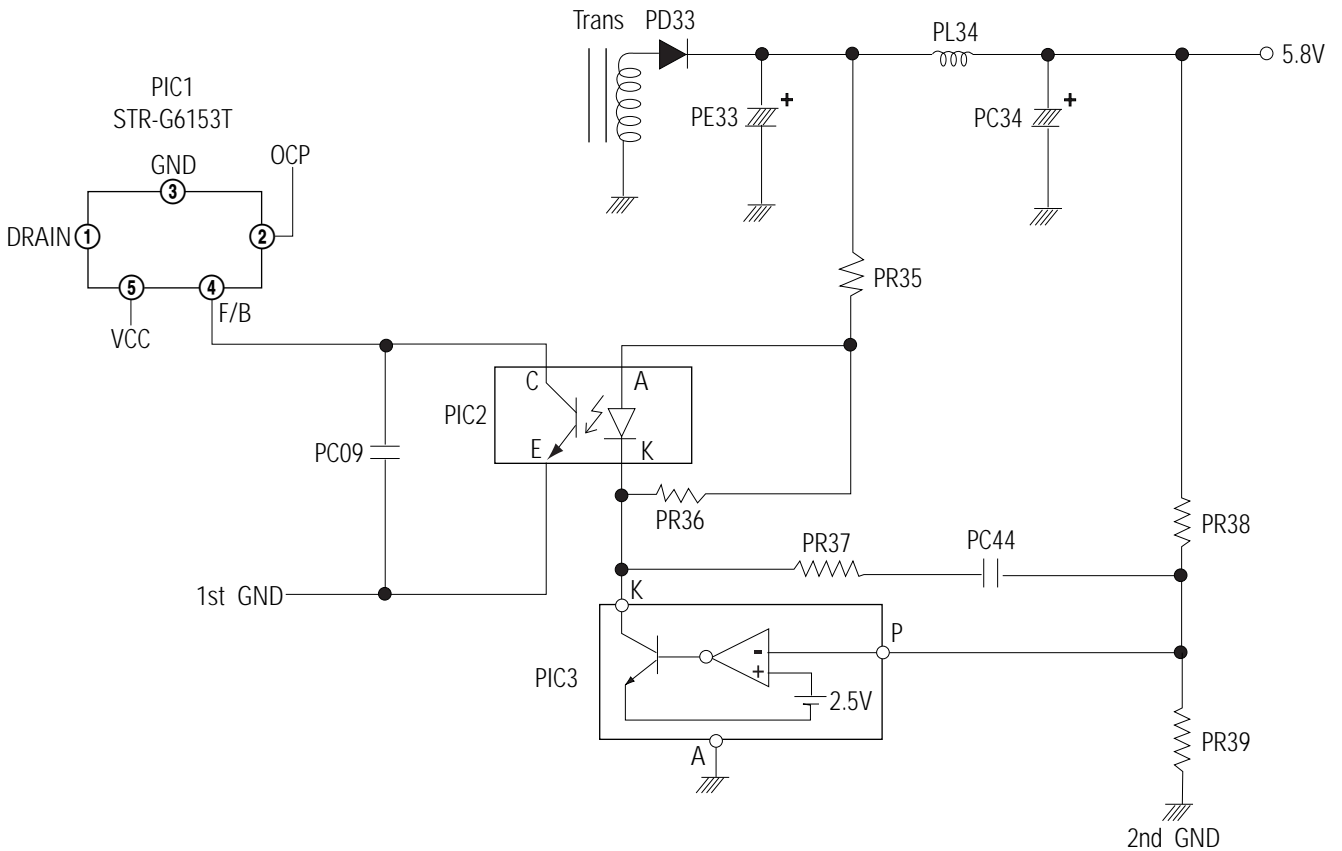

Fig. 6-8

- 1) F/B terminal of PIC1 determines output duty cycle.
- 2) C-E(Collector-Emitter) of PIC2 and F/B potential of PIC1 are same.

◆ Operation descriptions

- 1) Internal OP-Amp '+' base potential of PIC3 is 2.5V and external '-' input potential is connected with PR38 and PR39 to maintain V_{out} of 5.8V. ($V_{out} = ((PR36 \times PR39) / PR39) \times 2.5V$)
- 2) If load of 5.8 V terminal increases(or AC input voltage decreases) and V_{out} decreases below 5.8V, then :
 PIC3 'P' potential down below 2.5V --> PIC3 A-K of base current down --> PIC3 of A-K current down -->
 PIC2 Diode current down --> PIC2 C-E current down --> PIC2 C-E voltage up --> PIC1 F/B voltage up -->
 Out Duty up --> Transformer 1st current up --> Transformer 1st power up --> V_{out} up --> Maintain V_{out} 5.8V
- 3) If load of 5.8 V terminal decreases(or AC input voltage rises) and V_{out} rises above 5.8V, then :
 Reverse sequence of the above description --> Duty down --> V_{out} down --> Maintain 5.8V (i.e., the feedback to maintains 5.8V).
 - ❶ PR35, PR36 : Reduce 5.8V overshoot
 - ❷ PR37, PC44 : Prevent PIC3 oscillation(for phase correction)
 - ❸ PC09 : Adjust feedback response rate

6-1-3 Internal Block Diagram

6-1-3 (a) Internal Block Diagram of S.M.P.S. Circuit

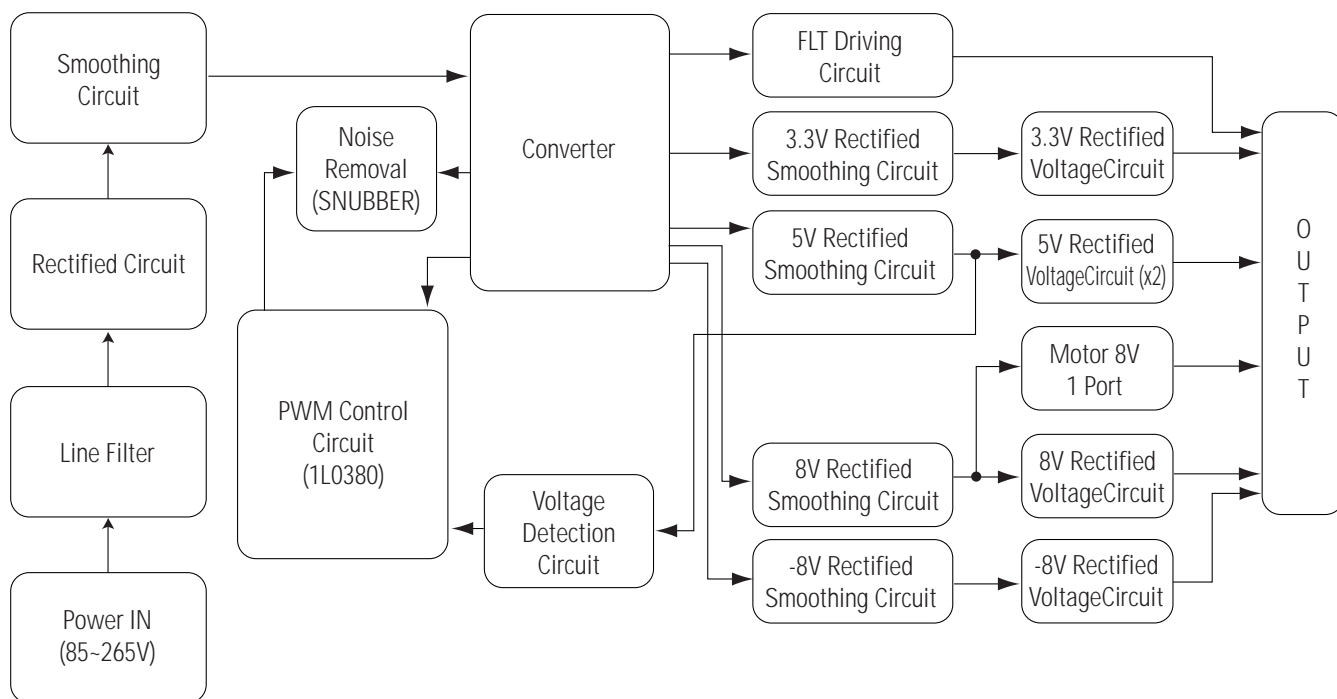

Fig. 6-9

6-1-3 (b) PIC1 (STR-G6153T) Internal Block Diagram

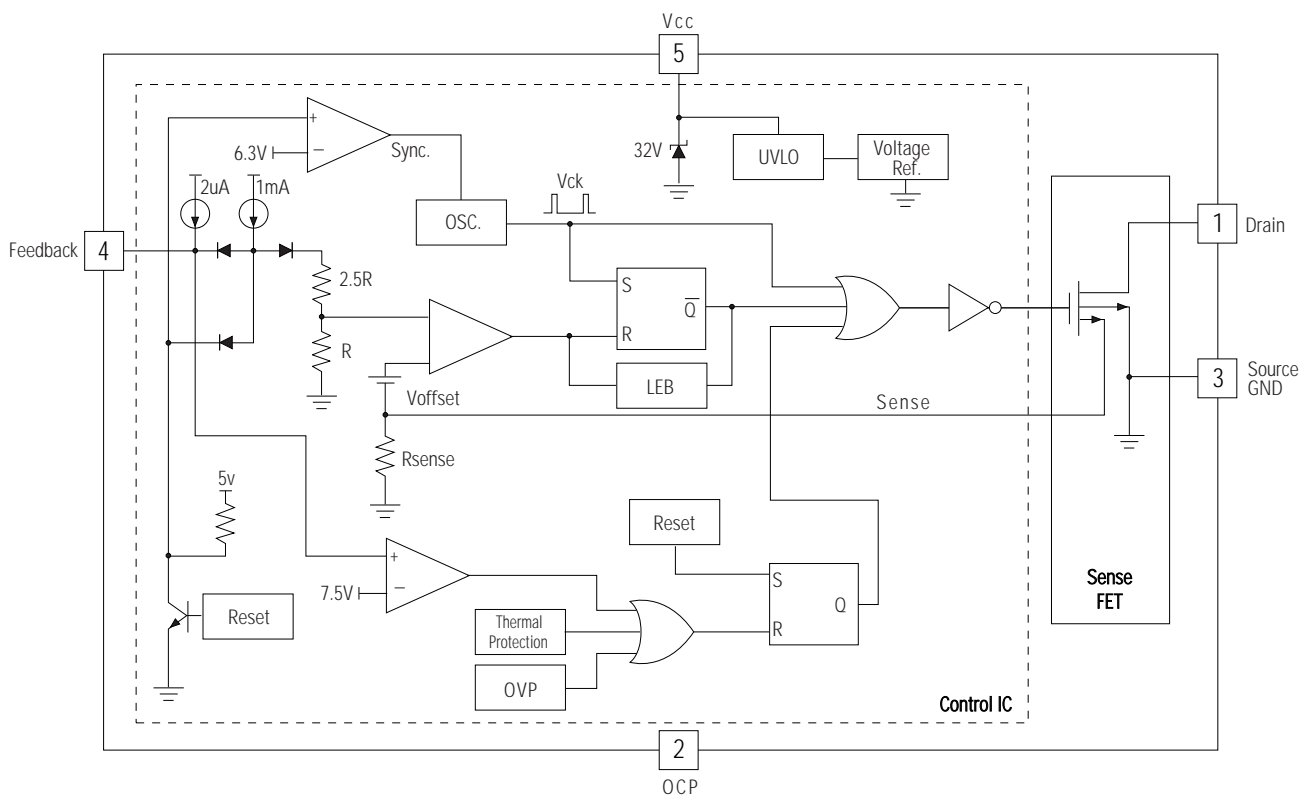

Fig. 6-10

6-2 RF

6-2-1 RIC1 (KS1461)

KS1461 is combined with KS1452 and KS1453 as bipolar IC developed for DVD SERVO system. Main features include DVD waveform equalizing, CD waveform equalizing, focus error signal generation, 3-beam tracking error signal generation, DPD 1-beam tracking error, defect, envelope, MIRR output, etc. after receiving the pick-up output converted into I/V.

6-2-1 (a) Basic Potentiometer

KS1461 uses a single power method and each circuit is based on V of 2.5V. V (Pin 12, 20, 24, 67) terminal is needed for IC, which uses the peripheral V.

6-2-1(b) RF signal

Fig. 6-11 shows the flow of signal generated by the pick-up. A, B, C, D signals detected from pick-up are converted in to RF signal(A+B+C+D) via RF summing AMP.

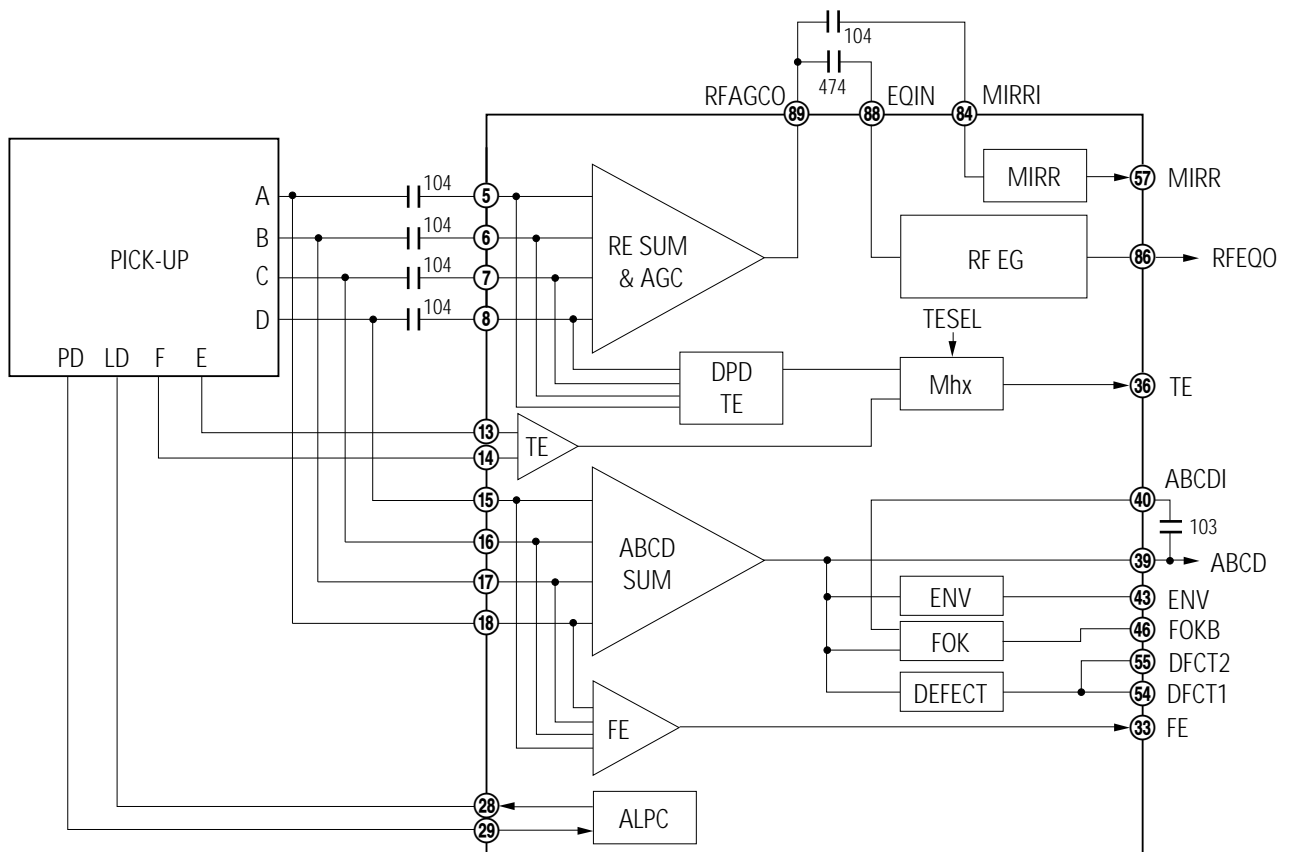

Fig. 6-11

Fig. 6-12 shows the waveform-equalizing block diagram for the RF signal.

It outputs to EQout (Pin 86) terminal by initially changing switching AMP gain of DVD and CD, and then adjusting the level in RF SUM & AGC. It controls RF SUM & AGC gain by means of Pin 89-95 and interfaces with PWM signal, (output from PWM terminal of KS1453, via low-pass filter to adjust boost gain and peak frequency. EQout terminal is connected with EQin (Pin 86).

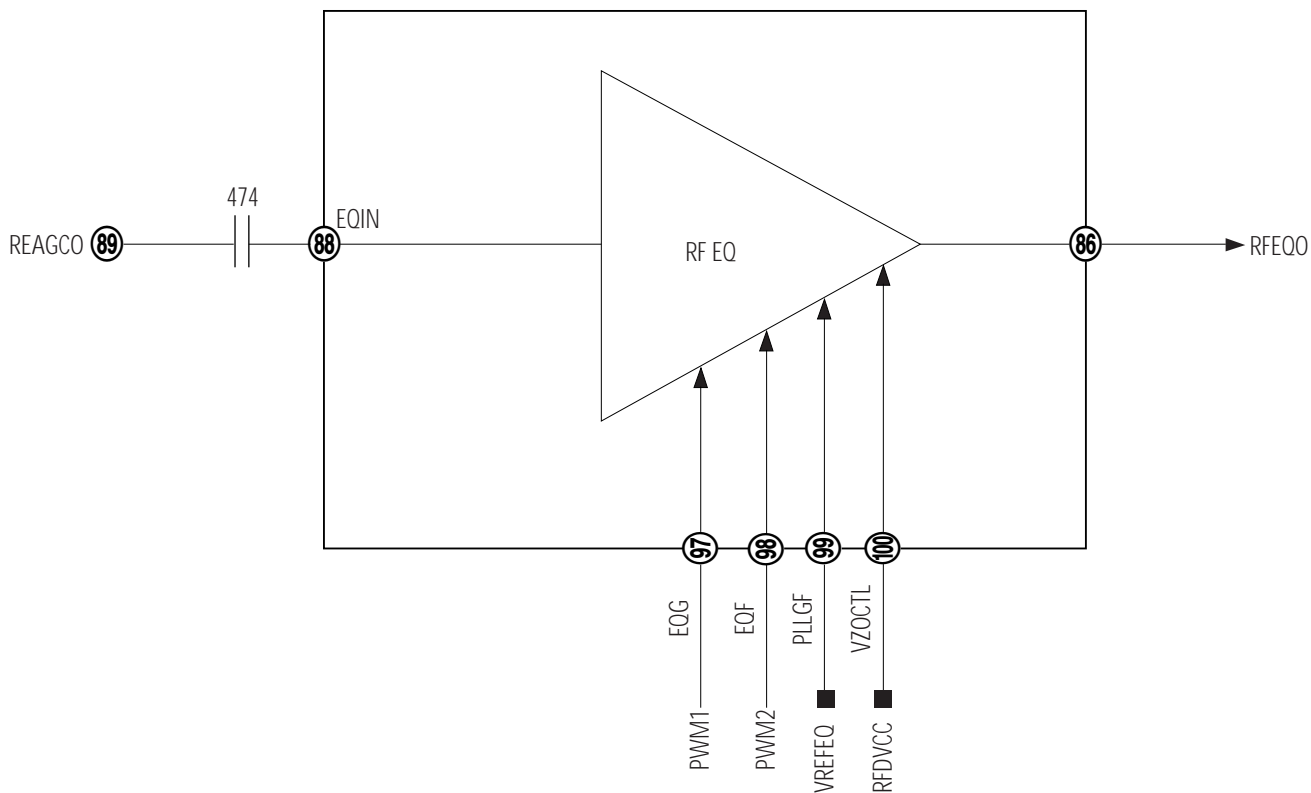

Fig. 6-12

The control parameters of DVD EQ and CD EQ are as follows.

1) DVD CD EQ control parameter

- ❶ EQG (Pin 97) : Changes the gain of peak frequency with EQ frequency characteristic. Convert PWM signal, output from KS1453, into DC via low-pass filter.
- ❷ EQF (Pin 98) : Changes the peak frequency with EQ frequency characteristic. Convert PWM signal, output from KS1453, into DVD via low-pass filter.

6-3 System Control

6-3-1 Outline

The main micom peripheral circuit is composed of 16bit Micom (MIC1 ; TMP93CM41F), 8M EPROM (MIC8 ; AM27C080) for Microcode and data save, 512 byte EE-PROM (MIC5 ; KS24C020) for permanent storage of data needed at power off, MIC4 (74AC573) to latch only address in the bus where address and data are mixed, address decoder (MIC7 ; 74HC00) for selection of external device chip and 20MHz clock oscillator for micom operation. The Micom (MIC1 ; TMP93CM41F) mounted in main board analyzes the key commands of front panel or instructions of remote control through communication with Micom (FIC1 ; LC86P6232) of front and controls the devices on board to execute the corresponding commands after initializing the devices connected with micom on board at power on.

6-3-2 Block Diagram

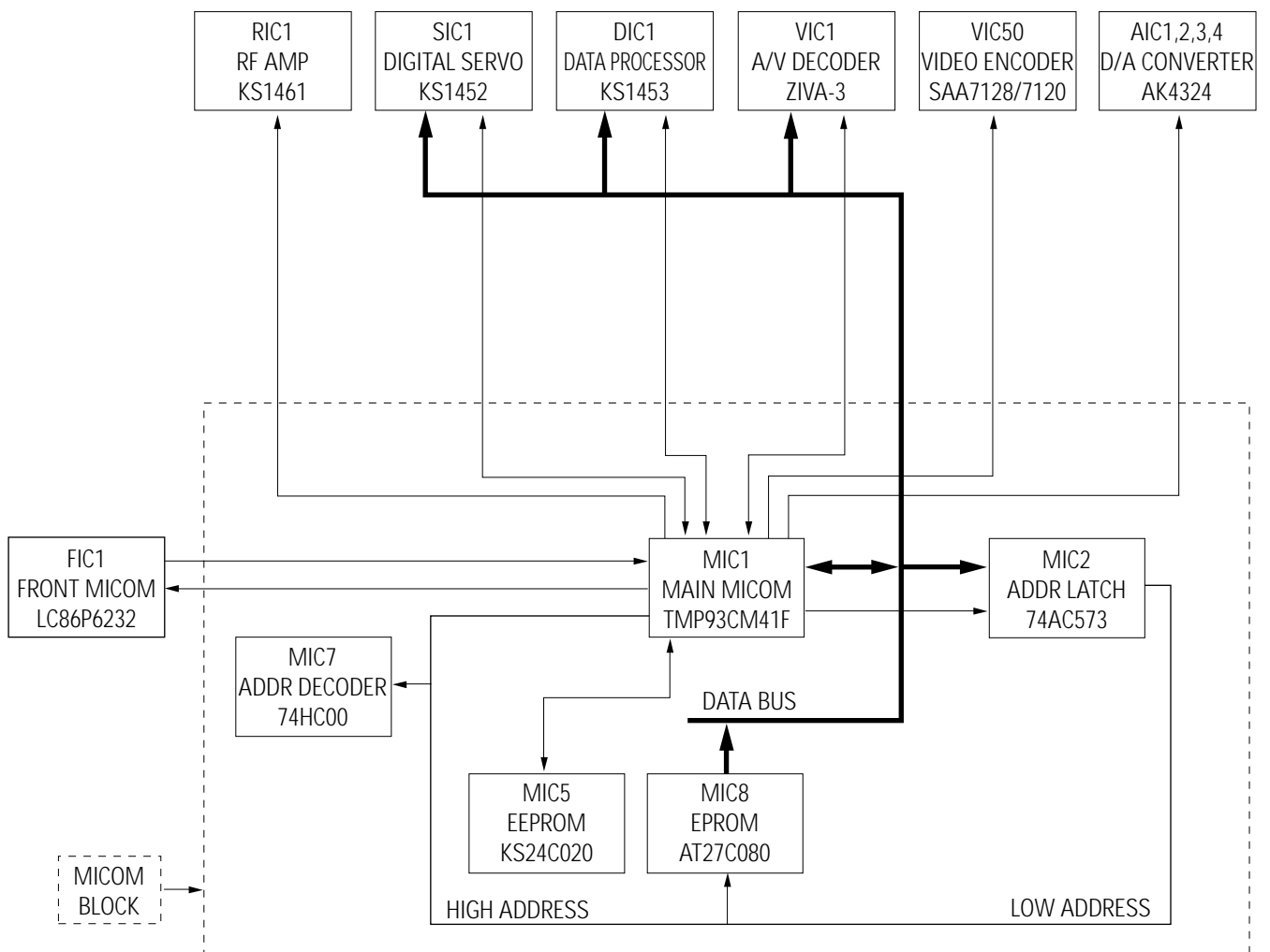

Fig. 6-13

6-3-3 Waveform Description

When micom accesses each device sharing bus, it falls the chip select signal of corresponding chip to (CS2:MIC8-22, /DSPCS:DIC1-2, /DVDCS:VIC1-206/SRVCS:SIC1-10) 0 (Low) before trial.

So to speak, the bus is used by time-division as shown in Fig 6-14, 6-15, 6-16.

Two and more devices can't be accessed simultaneously.

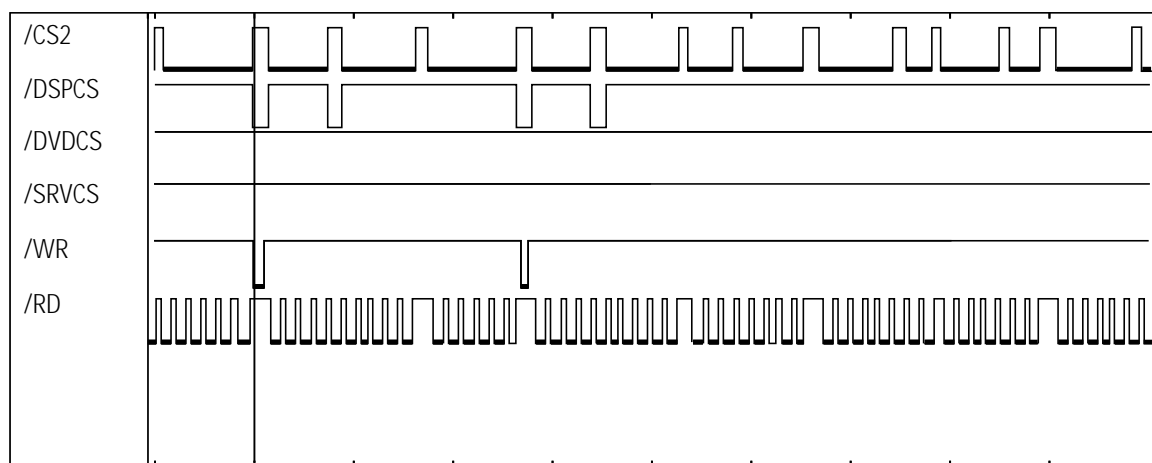

Fig. 6-14

- CH1 : CS2 (MIC8-22, EPROM CHIP SELECT)
- CH2 : DSPCS (DIC1-2, DATA PROCESSOR CHIP SELECT)
- CH3 : DVDCS (VIC1-206, A/V DECODER CHIP SELECT)
- CH4 : SRVCS (SIC1-10, DIGITAL SERVO CHIP SELECT)
- CH5 : WR (MIC1-73, MICOM OUTPUT WRITE SIGNAL)
- CH6 : RD (MIC1-72, MICOM OUTPUT READ SIGNAL)

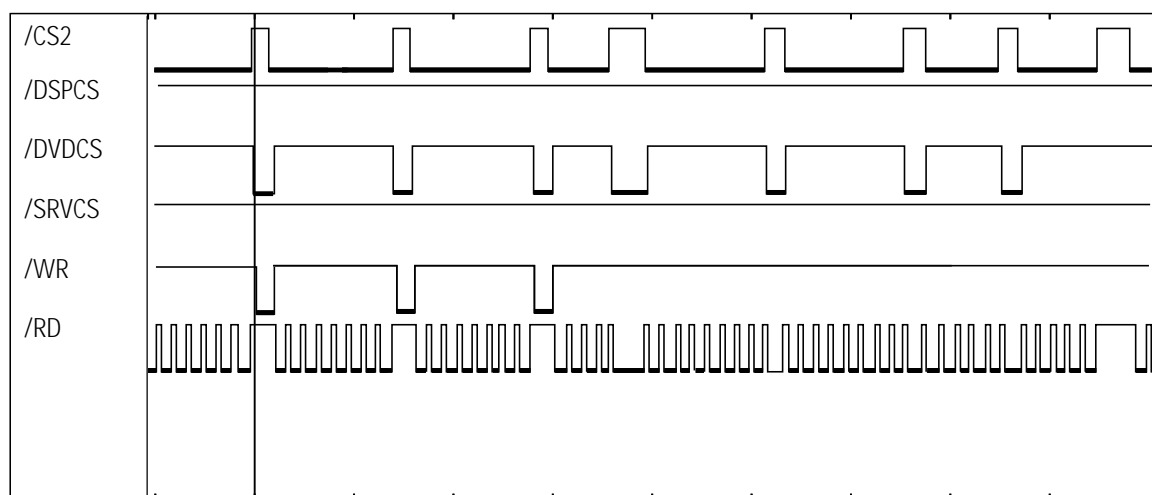

Fig. 6-15

- CH1 : CS2 (MIC8-22, EPROM CHIP SELECT)
- CH2 : DSPCS (DIC1-2, DATA PROCESSOR CHIP SELECT)
- CH3 : DVDCS (VIC1-206, A/V DECODER CHIP SELECT)
- CH4 : SRVCS (SIC1-10, DIGITAL SERVO CHIP SELECT)
- CH5 : WR (MIC1-73, MICOM OUTPUT WRITE SIGNAL)
- CH6 : RD (MIC1-72, MICOM OUTPUT READ SIGNAL)

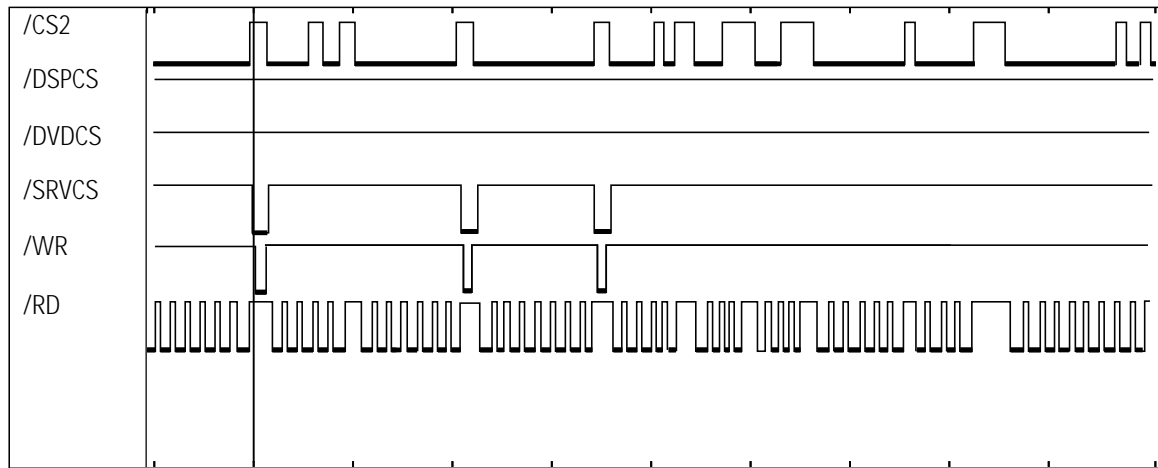

Fig. 6-16

- CH1 : CS2 (MIC8-22, EPROM CHIP SELECT)
- CH2 : DSPCS (DIC1-2, DATA PROCESSOR CHIP SELECT)
- CH3 : DVDCS (VIC1-206, A/V DECODER CHIP SELECT)
- CH4 : SRVCS (SIC1-10, DIGITAL SERVO CHIP SELECT)
- CH5 : WR (MIC1-73, MICOM OUTPUT WRITE SIGNAL)
- CH6 : RD (MIC1-72, MICOM OUTPUT READ SIGNAL)

6-4 Servo

6-4-1 Outline

SERVO system of DVD is divided into Focusing SERVO, Tracking SERVO, SLED Linked SERVO and CLV SERVO (DISC Motor Control SERVO).

1) Focusing SERVO

Focuses the optical spot output from object lens onto the disc surface. Maintains a uniform distance between object lens of Pick-up and disc (for surface vibration of disc).

2) Tracking SERVO

Make the object lens follow the disc track in use of tracking error signal (created from Pick-up).

3) SLED Linked SERVO

When the tracking actuator inclines outwardly as the object lens follows the track during play, the SLED motor moves slightly (and counteracts the incline).

4) CLV SERVO (DISC Motor Control SERVO)

Controls the disc motor to maintain a constant linear velocity (necessary for RF signal).

6-4-2 Block Diagram

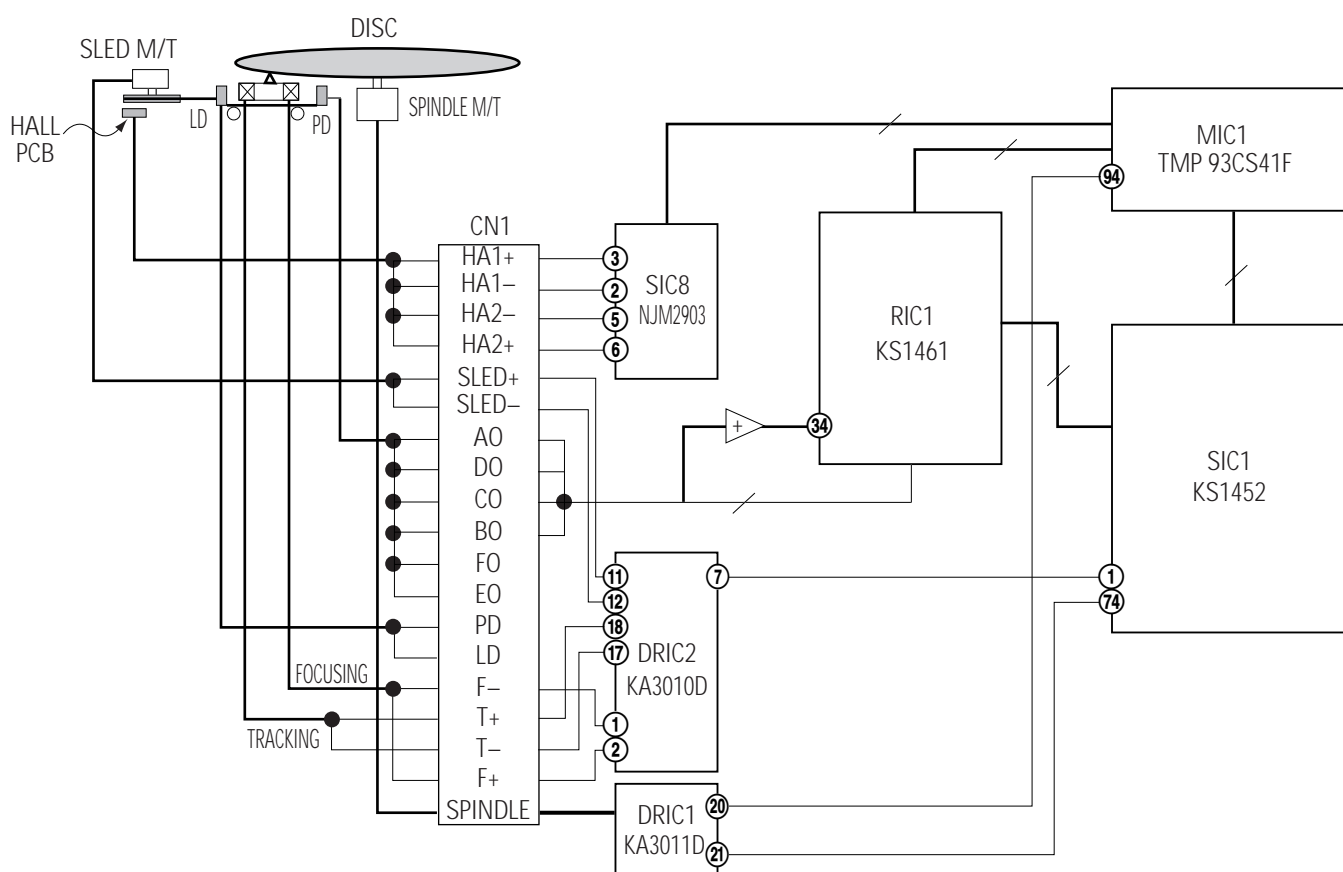

Fig. 6-17

6-4-3 Operation

1) FOCUSING SERVO

(1) FOCUS INPUT

The focus loop is changed from open loop to closed loop, and the triangular waveform moves the object lens up and down (at pin 75 of SIC1 during Focus SERVO ON.) At that time, S curve is input to pin 65 of SIC1.

ABAD (pin 39 of RIC1) signal, summing signal of PD A, B, C, D, is generated, and zero cross(2.5V) point occurs when S curve is focused and ABAD signal exceeds a preset, constant value. The focus loop is changed to closed loop, and the object lens follows the disc movement, maintaining a constant distance from the disc. (these operations are same in CD and DVD).

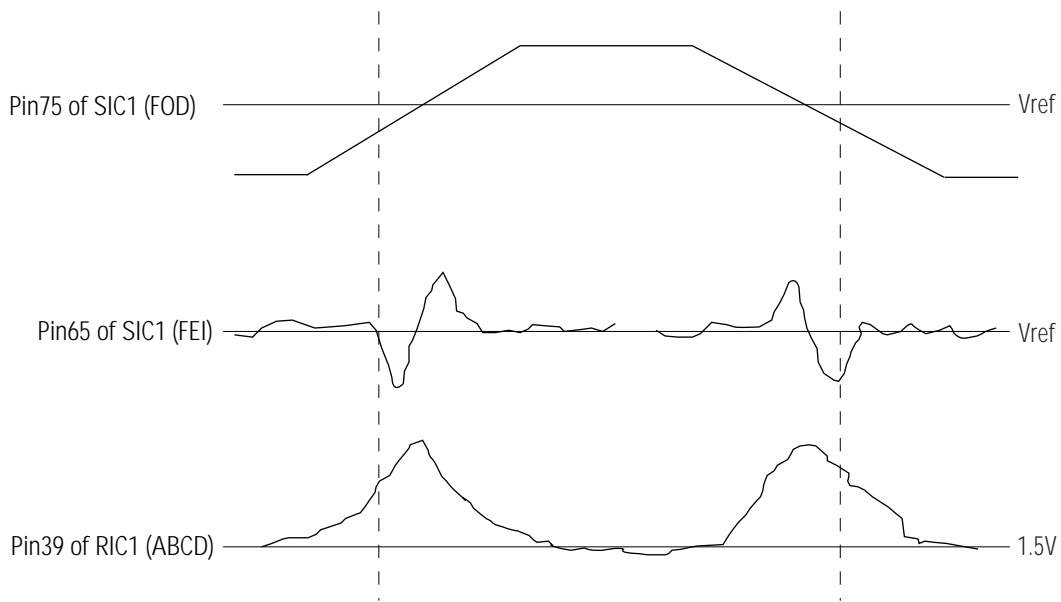

Fig. 6-18

(2) PLAY

When focus loop closes the loop during focus servo on, both pin 65 and pin 75 of SIC1 are controlled by VREF voltage (approx. 2.5V), and pin 1, 2 of DRIC2 are approximately 4.5V.

2) TRACKING SERVO

(1) NORMAL PLAY MODE

① For DVD

Composite : The signal output from PD A, B, C, D of Pick-up, the tracking error signal (pin36 of RIC1) uses the phase difference of A+C and B+D in RIC1, and inputs to terminal 64 of SIC1. Then, it is output to SIC1 pin 76 via digital equalizer, and applied to the tracking actuator through DRIC2.

Pins 17, 18 of SIC1 are controlled by VREF(approx. 2.5V) during normal play.

Meanwhile, DVD repeats the track jump from 1 to 4 in inner direction at normal play (because data- read speed from disc is faster than data output speed on screen).

② For CD, VCD

Receive the signal output through E, F of Pick-up, from RIC1. The tracking error signal is similar to DVD.

(2) SEARCH Mode :

Search mode : Fine seek,(Moving the tracking actuator slightly little below 255 track) and coarse search, moving much in use of sled motor. The coarse search will be described in sled linked servo and now, the fine seek is explained shortly.

If the object lens is located near target, cut off the tracking loop and give the control signal as many as desired count to move the tracking actuator via SIC1 pin 76 terminal(TRD).

3) SLED LINKED SERVO

- Normal play mode

Move SLED motor slightly by means of PWM signal in SIC1 pin 73, as the tracking actuator moves along with track during play. Control to move the entire Pick-up as the tracking actuator moves.

- Coarse search mode

In case of long-distance search (such as chapter search), SIC1 uses sled FG (SIC8 pin 1, 7, which is generated) by rotation of sled motor via hall PCB. Then, read ID and compute the existing track count after input of next track. If the existing track count is within fine seek range, tracking begins using fine seek.

4) CLV SERVO(DISC MOTOR CONTROL SERVO)

Input RF signal (from Pick-up) to SIC1 pin59. Detect SYNC signal from RF in SIC1, and output PWM signal to SIC1 pin 55 for constant linear velocity.

6-5 DVD Data Processor

6-5-1 Outline

DIC1(KS1453) performs Sync detection, EFM/EFM demodulation and error correction and Spindle motor control (CLV control) after inputting sliced EFM signal of RF signal at disc playback and EFM read clock (PLCK) signal generated from PLL. Outputs data which converted to the last audio and video from A/V decoder(VIC1). KS1453 uses external memory(4M DRAM) as buffer as well as for error correction and carries out Variable Bit Rate transfer function. VBR function uses the external buffer as buffer to absorb the difference of transfer rate occurring because the transfer rate of disc playback is faster than data transfer rate demanded by A/V decoder(Video/Audio Signal Process Chip).

In case of general disc refresh, the memory is almost filled up periodically. It is because Write rate to memory after disc playback and signal process is faster than Read of A/V decoder. When the memory is filled, this status is reported by interrupt to main micom, which controls the servo to kick back the pick-up to the previous track after memorizing the last data read from disc until now. It takes some times to jump to the previous track and return to the original(jump location) again. The memory will have an empty space because A/V decoder reads out data of memory.

When the memory has an empty space, where data can be processed and written and the pick-up correctly gets to the original location(before kick back location) again, it reads data again avoids the interrupt of data read previously. The basic operation repeats to perform as described above.

6-5-2 Block Diagram

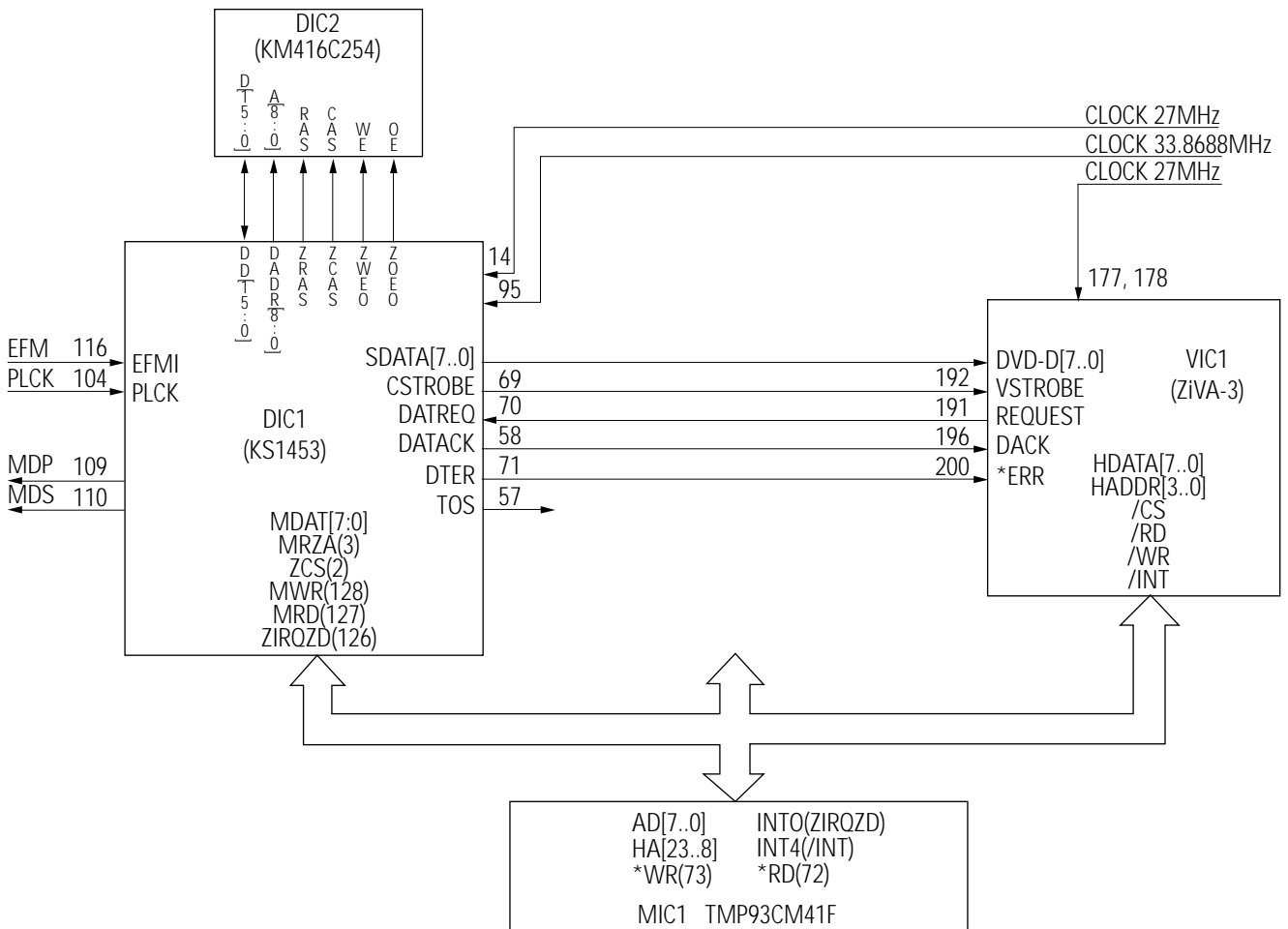

Fig. 6-19

6-5-3 Waveform Description

It measures the timing that data processed in DIC1 at DVD playback.

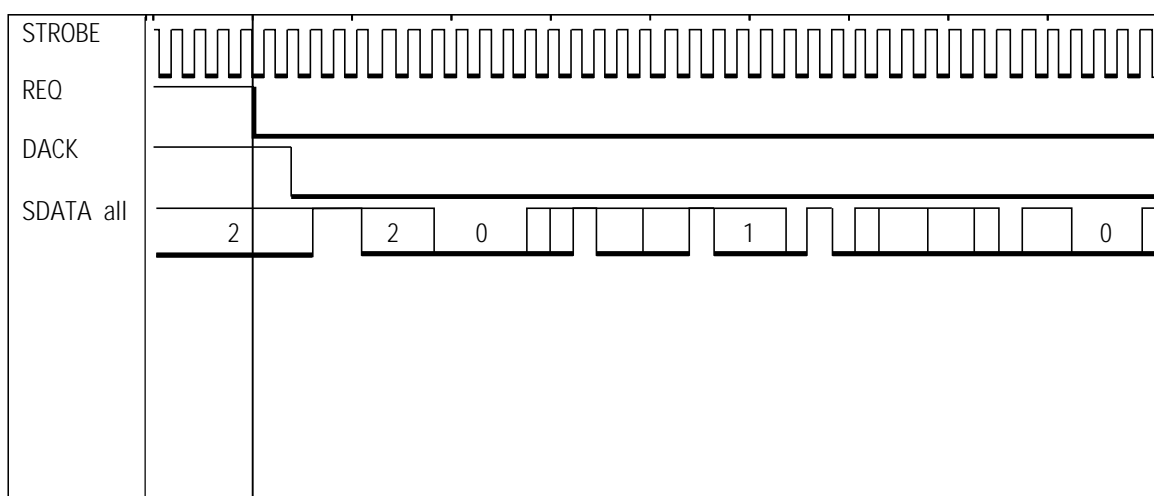

Fig. 6-20

- CH1 : STROBE (DIC1-69, CLOCK)
- CH2 : REQ (DIC1-70, DATA REQUEST)
- CH3 : DACK (DIC1-58, DATA ACKNOWLEDGE)
- CH4 : SDATA (DIC1-60-67, DATA)

6-6 Video

6-6-1 Outline

VIC50 sends VSYNC and HSYNC from VIC1(A/V decoder) and receives 8bit video data.

VIC50 does RGB encoding, copy guard processing and D/A conversion of 8bit video data inputted from VIC1(A/V decoder) by control of MIC1(Micom).

Video signal converted into analog signal is outputted via amplifier of analog part.

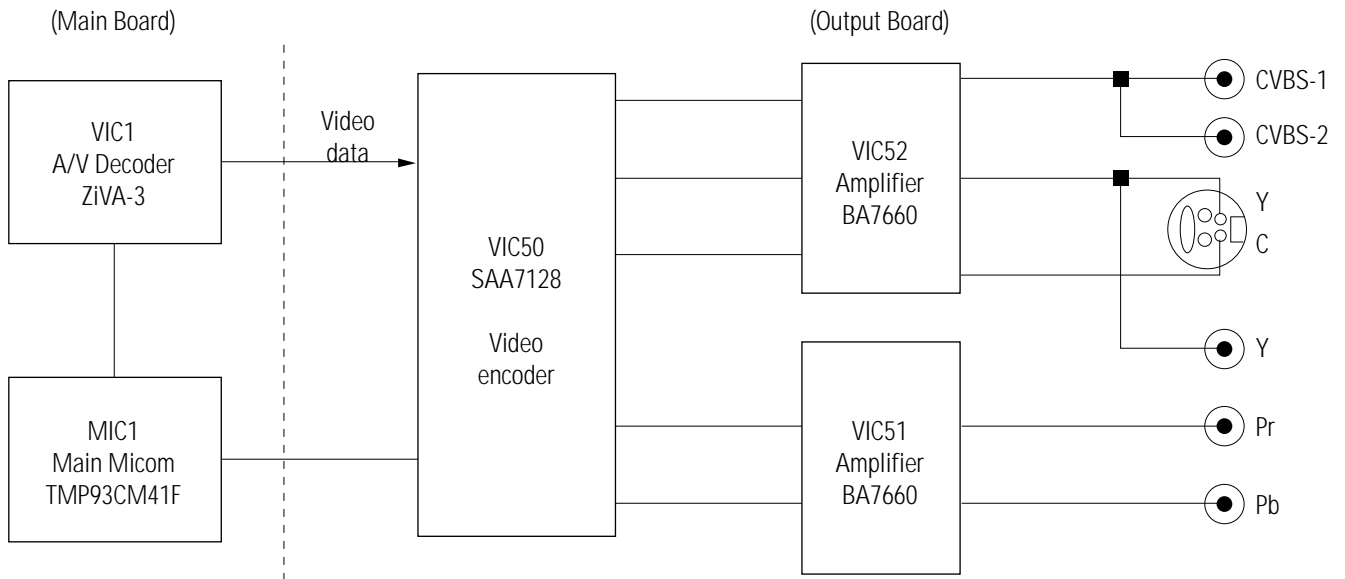

Fig. 6-21 Video Output Block Diagram

6-6-2 NTSC/PAL Digital Encoder (VIC50 : SAA7128)

VIC50 inputted from pin4 with 27MHz generates HSYNC and VSYNC which are based on video signal. Each HSYNC and VSYNC outputted from Pin8 and Pin7 are inputted to Pin157 and Pin158 of A/V decoder VIC1(ZIVA-3). VIC1 is the synchronous signals with the video signal and control the output timing of 8bit video signal of ITU-R601 format. (Pin180, 182, 184 ~ 189 (MSP))

8bit data is inputted to Pin9(MSB) and Pin16 of VIC50 and the inputted data is demuxed with each 8bit of Y/R-Y/B-Y. The separate signal is encoded to NTSC or PAL by control of MIC1. The above signals, that is CVBS (Composite Video Burst Synchronized)(Pin30), S-Video (Y:Pin27, C:Pin24), Y/Pb/Pr(Pin27/Pin29/Pin23) and GB(Pin26/Pin29/Pin23). In course of encoding, 8bit data can extend to 10bit or more. To convert the extended data to quantization noise as possible, VIC50 adopts 10bit D/A converter. VIC50 perform video en-coding as well as copy protection.

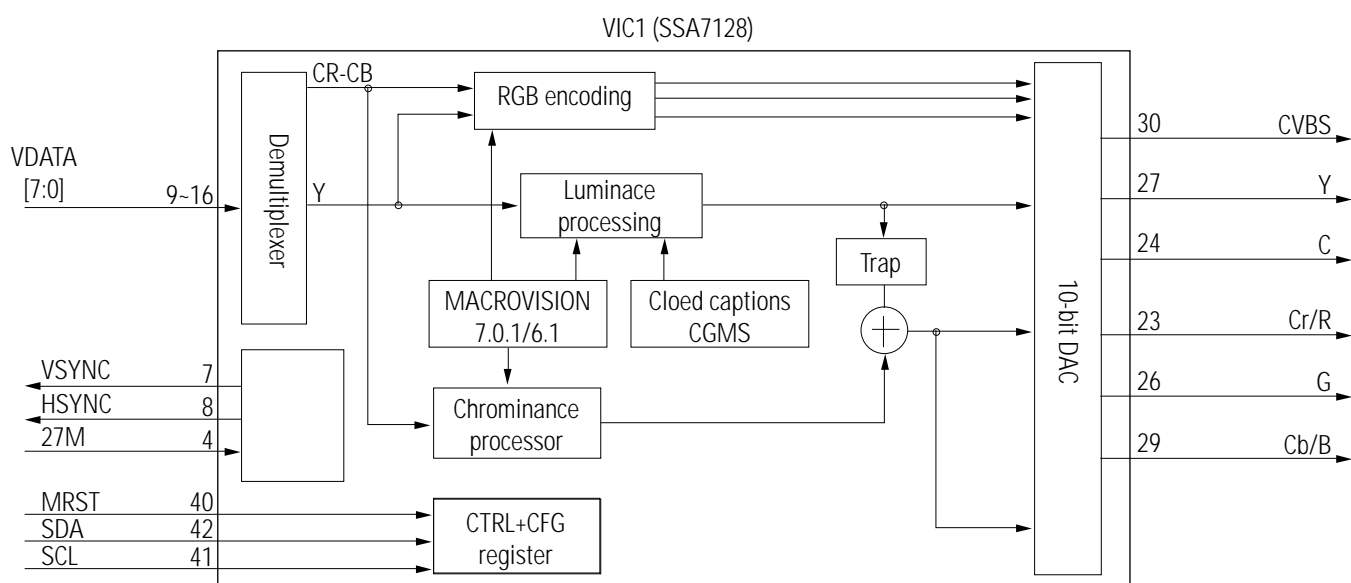

Fig. 6-22

6-6-3 Amplifier (VIC51, VIC52 : BA7660)

VIC51 and VIC52 are 6dB amplifier. Based on CVBS signal, the final output level must be 2Vpp without 75ohm terminal resistance. Because the level of video encoder output is only 1.1Vpp, the level is adjusted with the special amplifier. When mute of pin1 is high active, if the pin is floating and connected to power, the output signal is never outputted. CVBS, Y, C, Cr and Cb outputted from video encoder are inputted to VIC52 (Pin7, Pin2 and Pin4) and VIC51 (Pin7 and Pin4) respectively and outputted from VIC52 (Pin10, Pin15 and Pin13) and VIC51 (Pin10 and Pin 13). Pin9, Pin12 and Pin14 of VIC51 and VIC52 are feedback pin to SAG compensation(DC characteristic compensation of signal). Resistance(VR3-VR14) which is inserted to input terminal is bias resistance for input offset. The signal to which gain is adjusted by amplifier is outputted from jack via 75ohm.

6-6-4 Scart Jack Output

The AV1 of scart jacks is used for connecting a TV or other display devices and the AV2 for a VCR or other players. When the DVD player is turned on, the RGB, CVBS, or S-VIDEO is outputted to AV1 and CVBS to AV2. When the player is turned off, CVBS signal of the TV is inputted and CVBS or RGB of a VCR inputted via AV2 is outputted. In case of AV2, the reverse signal flow to that.

Switching of power on/off is controlled by SCIC1, SCIC2, and SCIC5.

The control signal (Pin 9,10,11) of SCIC1 and SCIC2 is outputted from PIN100 of FIC1 and connected to the signal(Pin 4) inverted by FIC3.

The control signal(Pin 9,10,11) of SCIC5 is also outputted from Pin100 of FIC1 and inverted again by SCQ8.

According to the characteristics that SCART Jack is supplied same pins for the output of CVBS signal and Y signal and for the R signal and C signal, SCIC3 lets the user select two signals in setup menu.

This control signal (Pin 9,10,11) of the switch is outputted from Pin 92 of FIC1.

The signal selected by switch is amplified by SIC4 and SIC6 and outputted through the SCART jack.

The scart jack has the function select signal (Pin 8 of AV1) that the TV can select automatically RF and the external video signal.

SCQ1 to SCQ7 are the circuit to point, FIC1 (Pin100, 94) controls. When the TV aspect ratio is 4/3 or 16/9, it is outputted 4.5 ~ 7V or 9.5 ~ 12V each. But, when the DVD video source is 16/9 and 16/9 wide is selected in setup menu, 4.5 ~ 7V is outputted. Otherwise, 9.5 ~ 12V is outputted.

When the player is turned off, the TV works with function selection by output signal of VCR in relation of SCQ9 and SCQ10.

RGB control signal (Pin 16 of AV1) is outputted that the TV can select between RGB and CVBS.

SCQ11 ~ SCQ14 and SCQ17 are for RGB control and controlled by FIC1 (Pin91).

When the player is turned off, receives VCR input (Pin 37 of AV2) and buffers in this circuit and then outputs to Pin 16 of AV1.

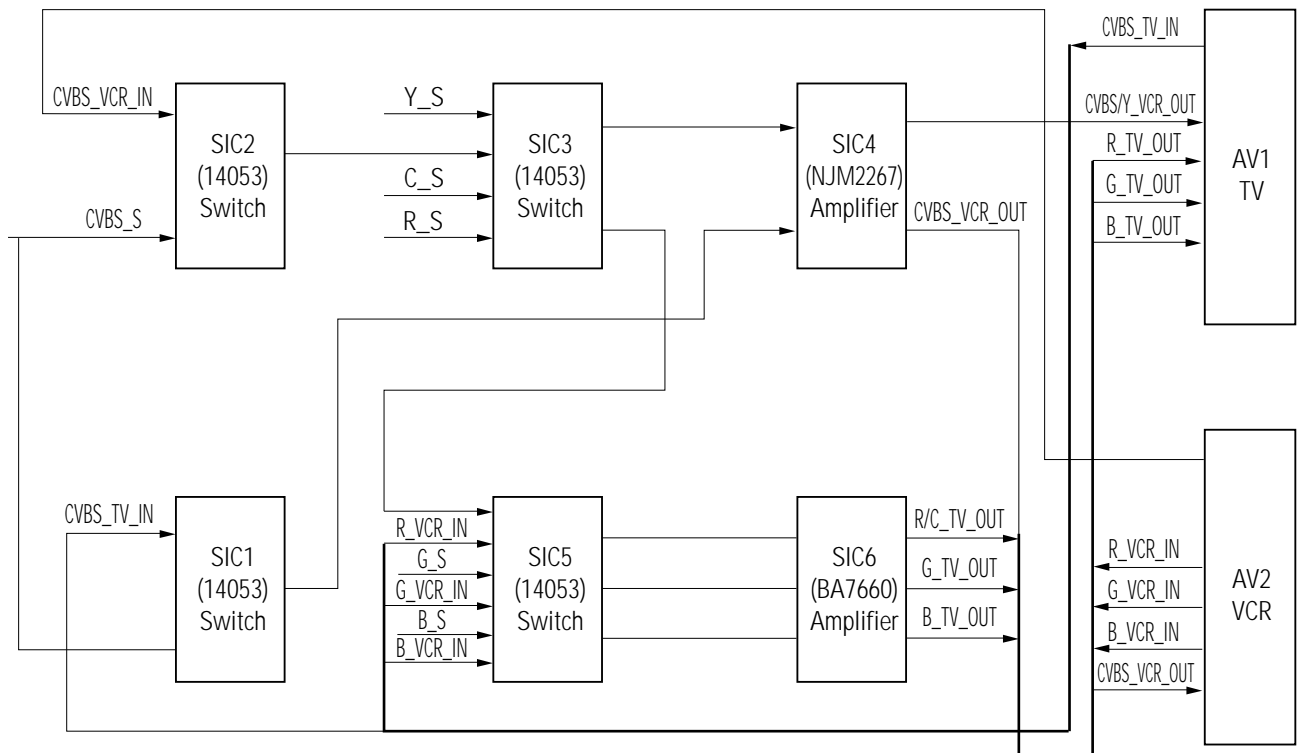

Fig. 6-23

6-7 Audio

6-7-1 Outline

The four data (Data 0~3) outputted from A/V decoder (VIC1 ; ZiVA-3) are supplied to DATA 0 for 2-channel mixed audio output and to DATA 1~3 for Analog audio output (5.1-channel).

The audio data (0~3) transmitted from A/V decoder (VIC1 ; ZiVA-3) are converted into analog signal via audio D/A converter and outputted via post filter and amplifier.

CD and VCD are outputted with only 2 channels audio data and transmit them to Data 0 and Data 1.

Front L/R channel is outputted in mixed audio output (L/R output) and analog audio output and surround L/R, center and subwoofer aren't outputted.

If DVD of 2 channels source disc is used, it is outputted by the same way with CD and VCD.

If 5.1-channel source disc, front L/R channel is outputted in Data 1, Surround L/R in Data 2 and Center/Subwoofer in Data 3. At that time, 5.1 channel can be downmixed in 2 channel in Data 0.

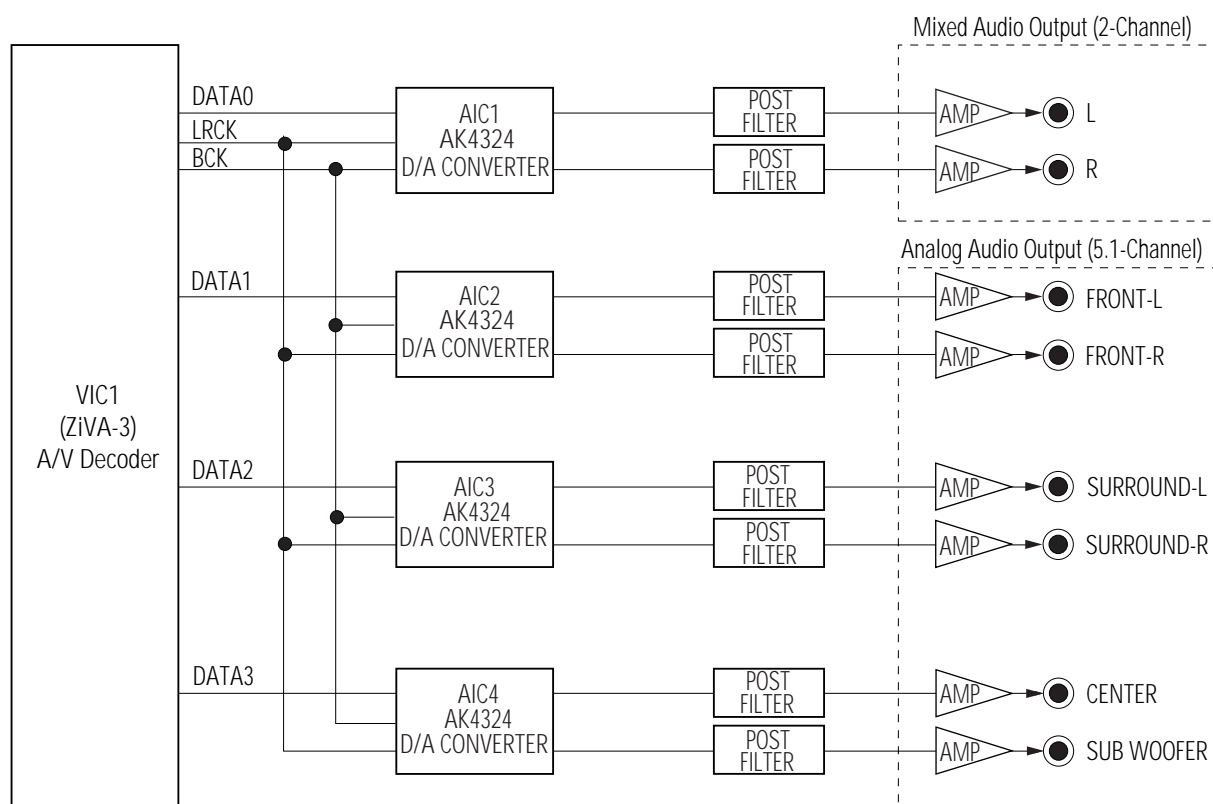

Fig. 6-24 Audio Output Block Diagram

6-7-2 DVD Audio Output

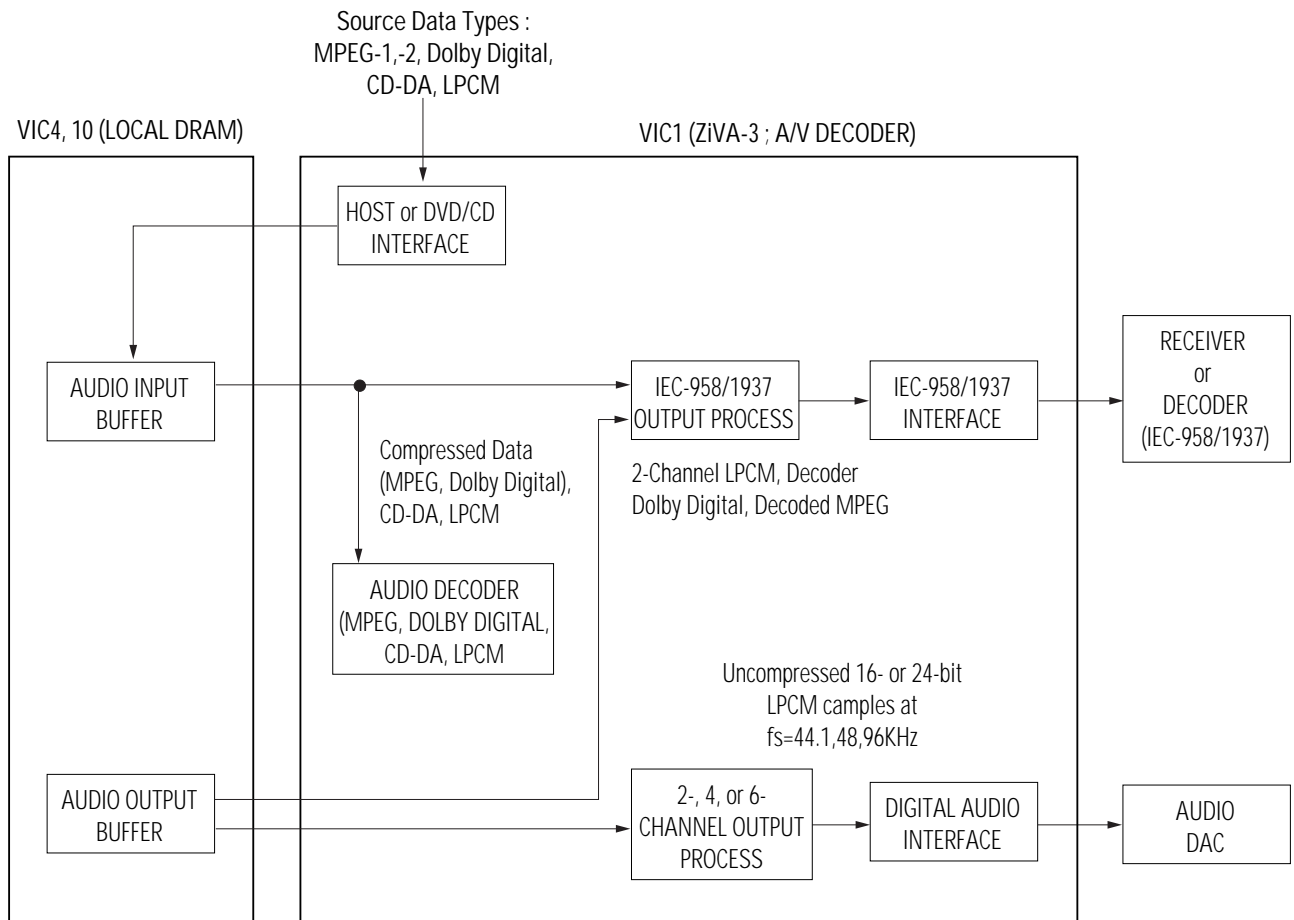

Fig. 6-25 Audio Decoder and Output Interface Datapath

1) Compressed Data

The audio data inputted to VIC1 (ZiVA-3) A/V decoder is divided into compressed data and uncompressed data. It is compressed data that is compressed with multi-channel audio data such as Dolby digital, MPEG, DTS, etc. The compressed data inputted to VIC1 (ZiVA-3) is converted into the uncompressed data of 2, 4, and 6 channels through ZiVA-3 built-in audio decoder and is outputted to Data 0, 1, 2, and 3 through digital audio interface. The compressed data is transmitted to external AC-3 amplifier or MPEG/DTS amplifier as IEC-958/1937 transmission data format compressed by ZiVA-3 built-in IEC-958 output process.

2) Uncompressed Data

The uncompressed data is that data isn't compressed, so it is called CD-DA, LPCM data. The 2 channels data is converted through audio decoder 2-channel data and Data 0 and Data 1 are outputted in digital audio interface. Via IEC-958 output process, they is transmitted to digital amplifier or AC-3/MPEG/DTS amplifier built in the external digital input source with IEC-958/1937 transmission format.

7. Troubleshooting

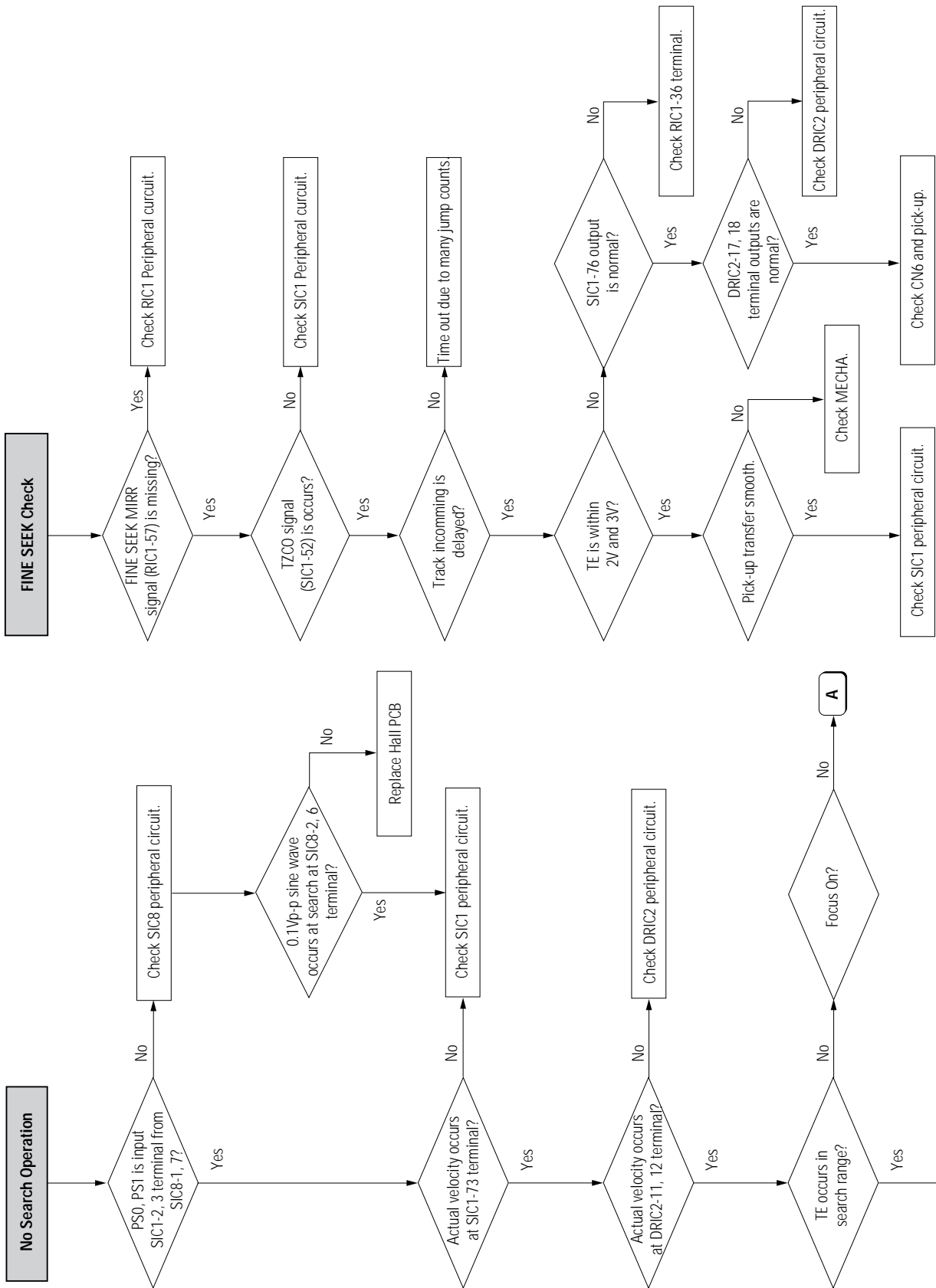

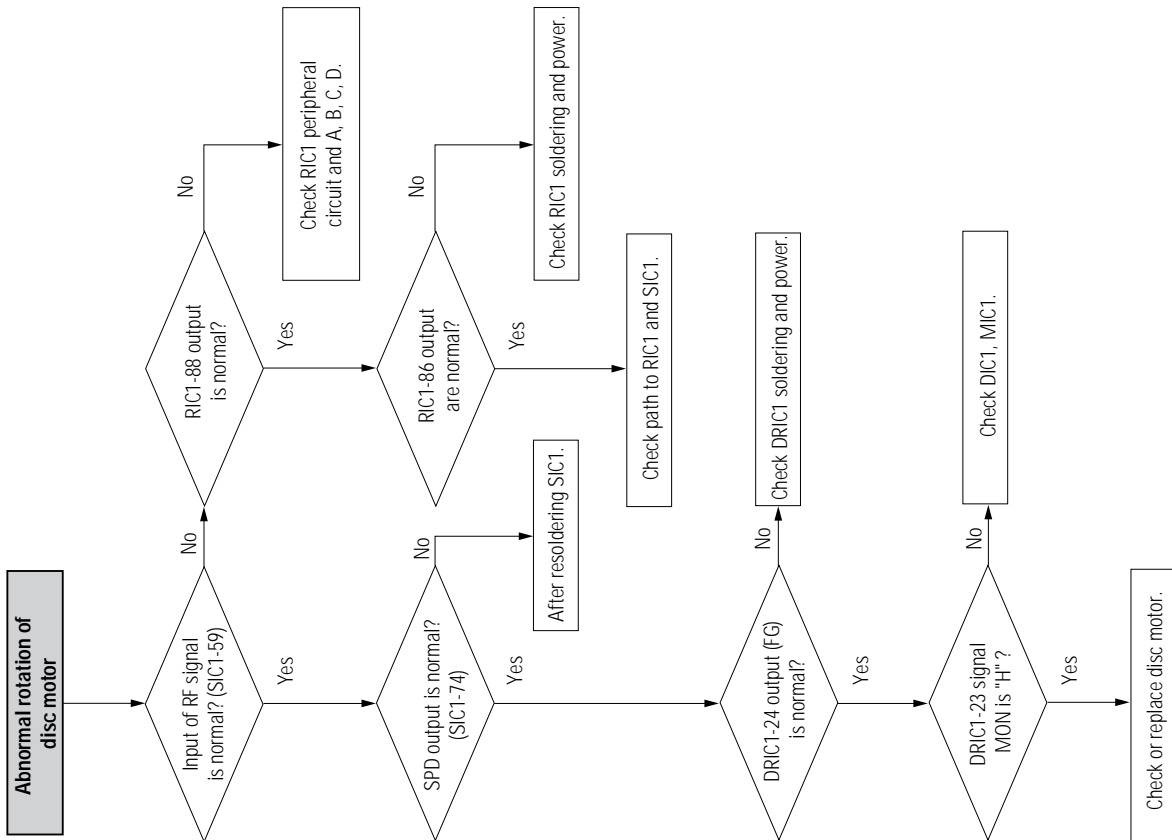
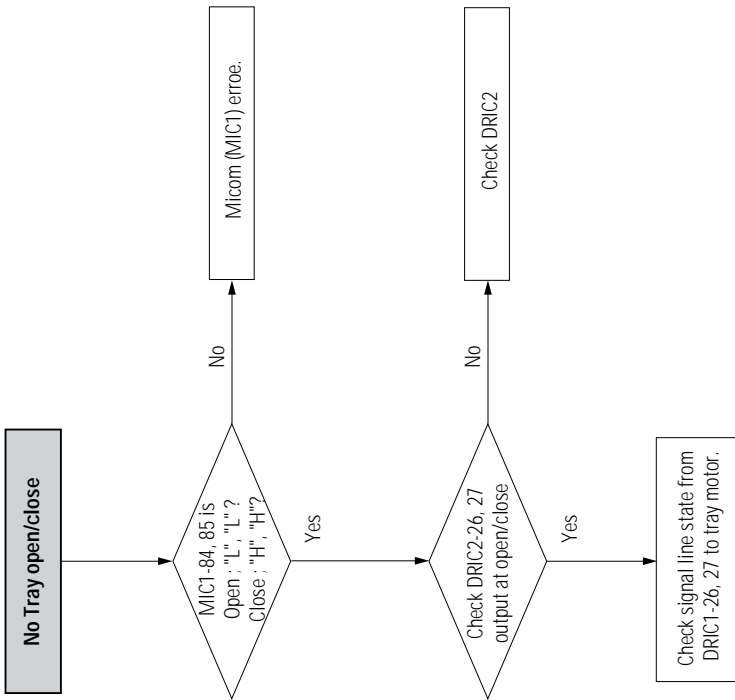

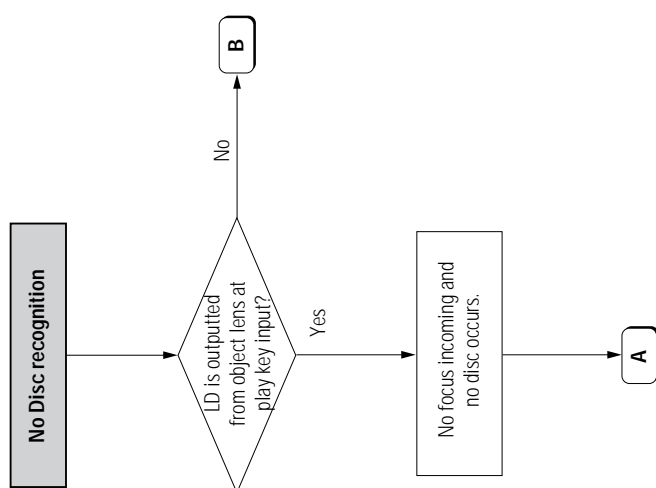
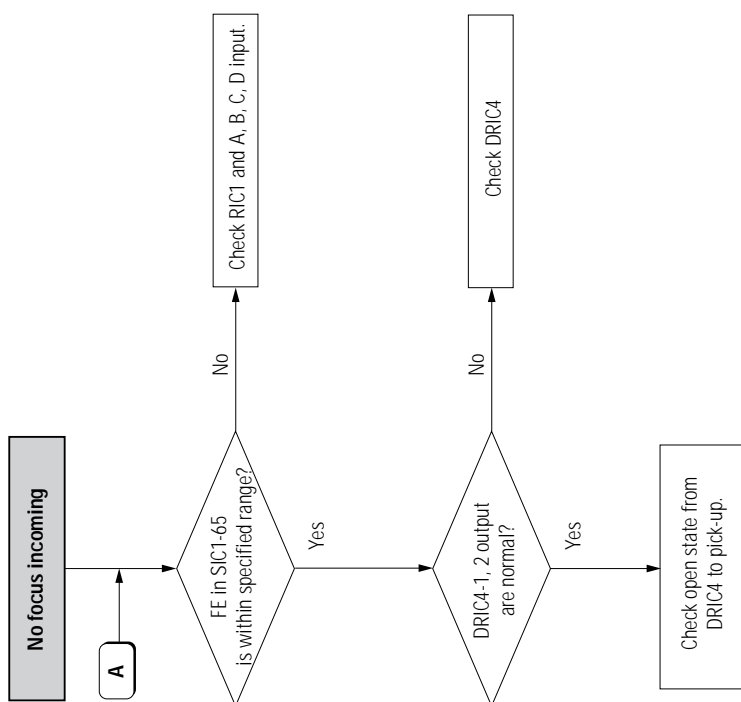

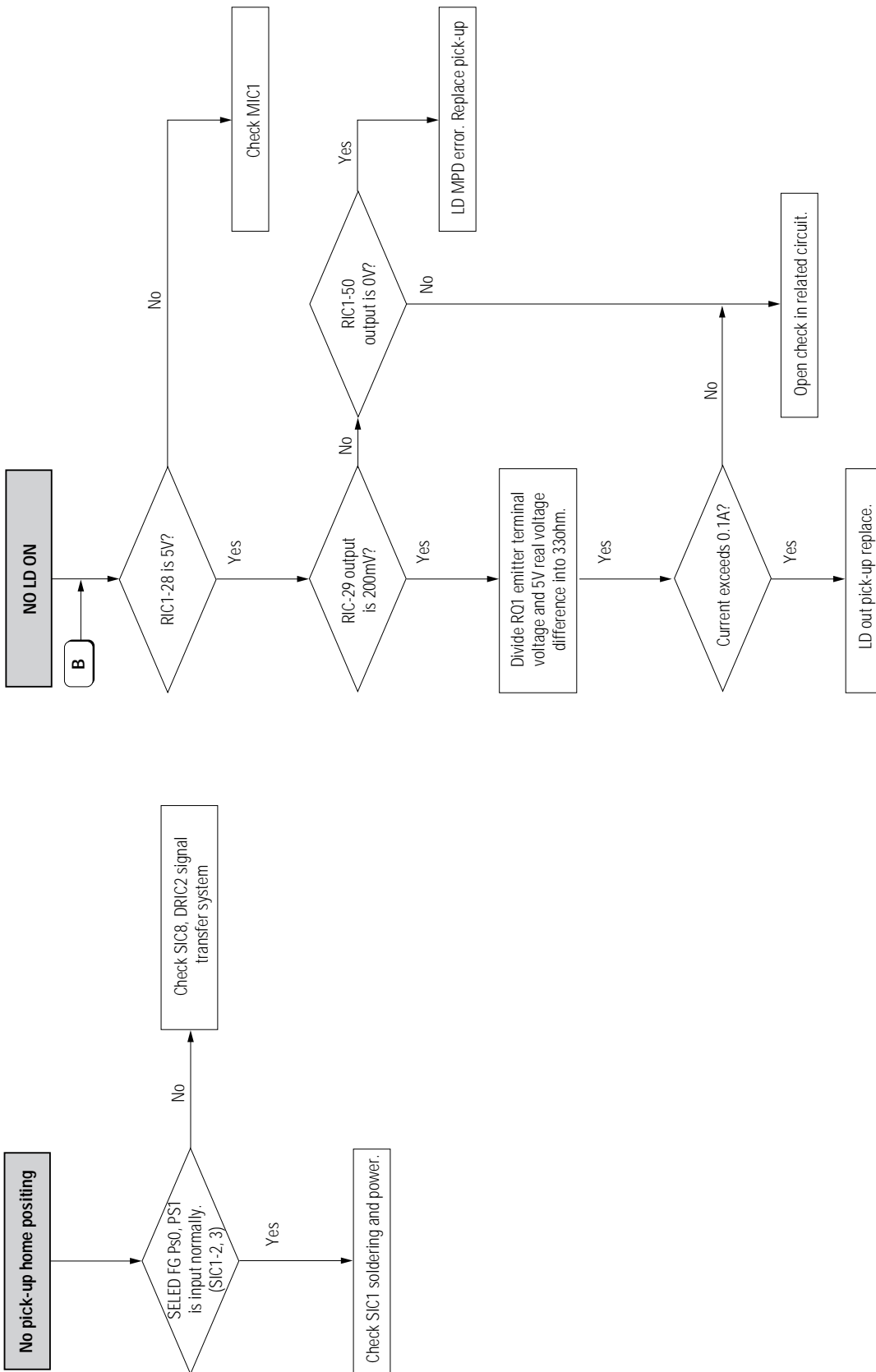

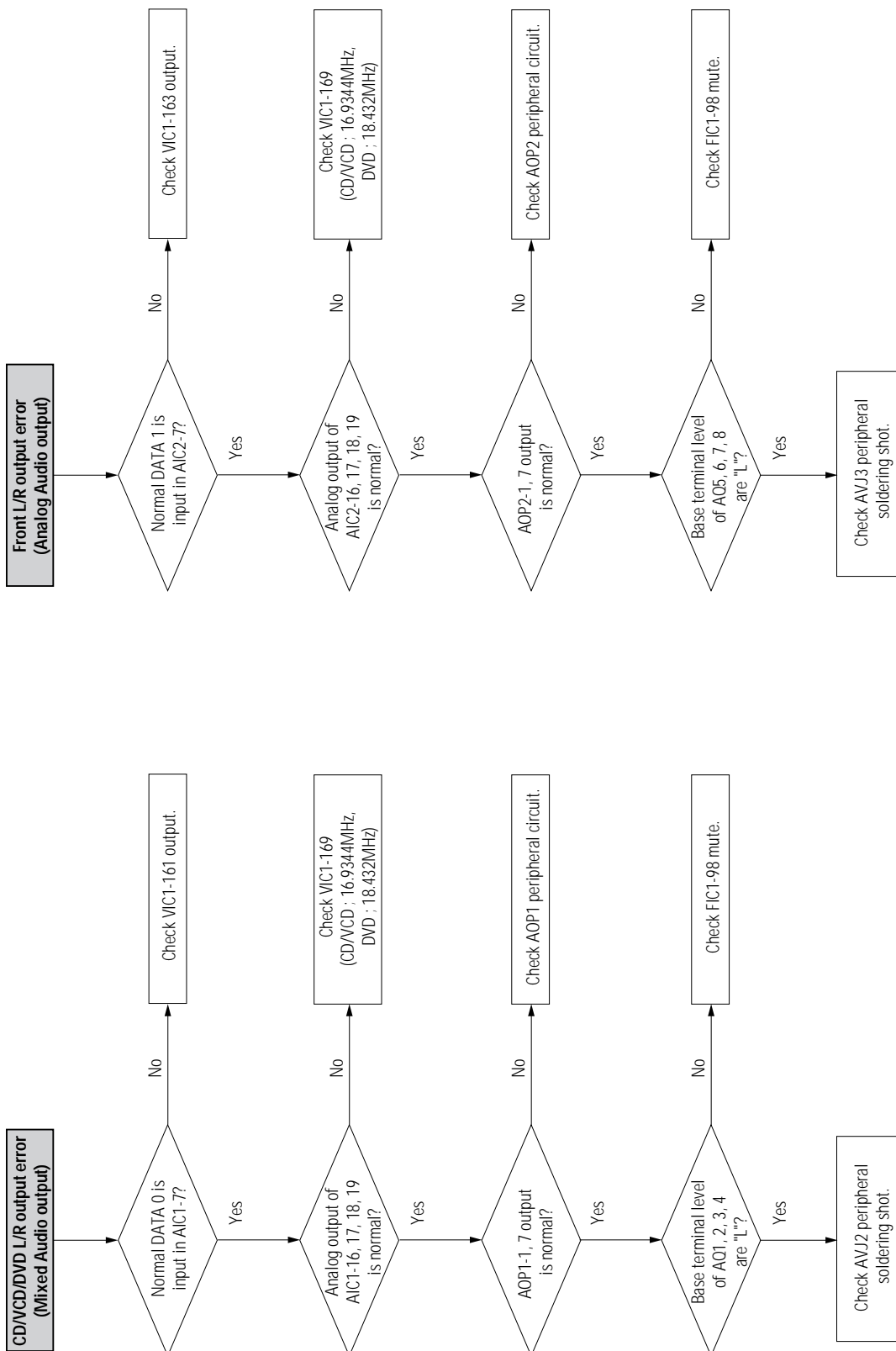

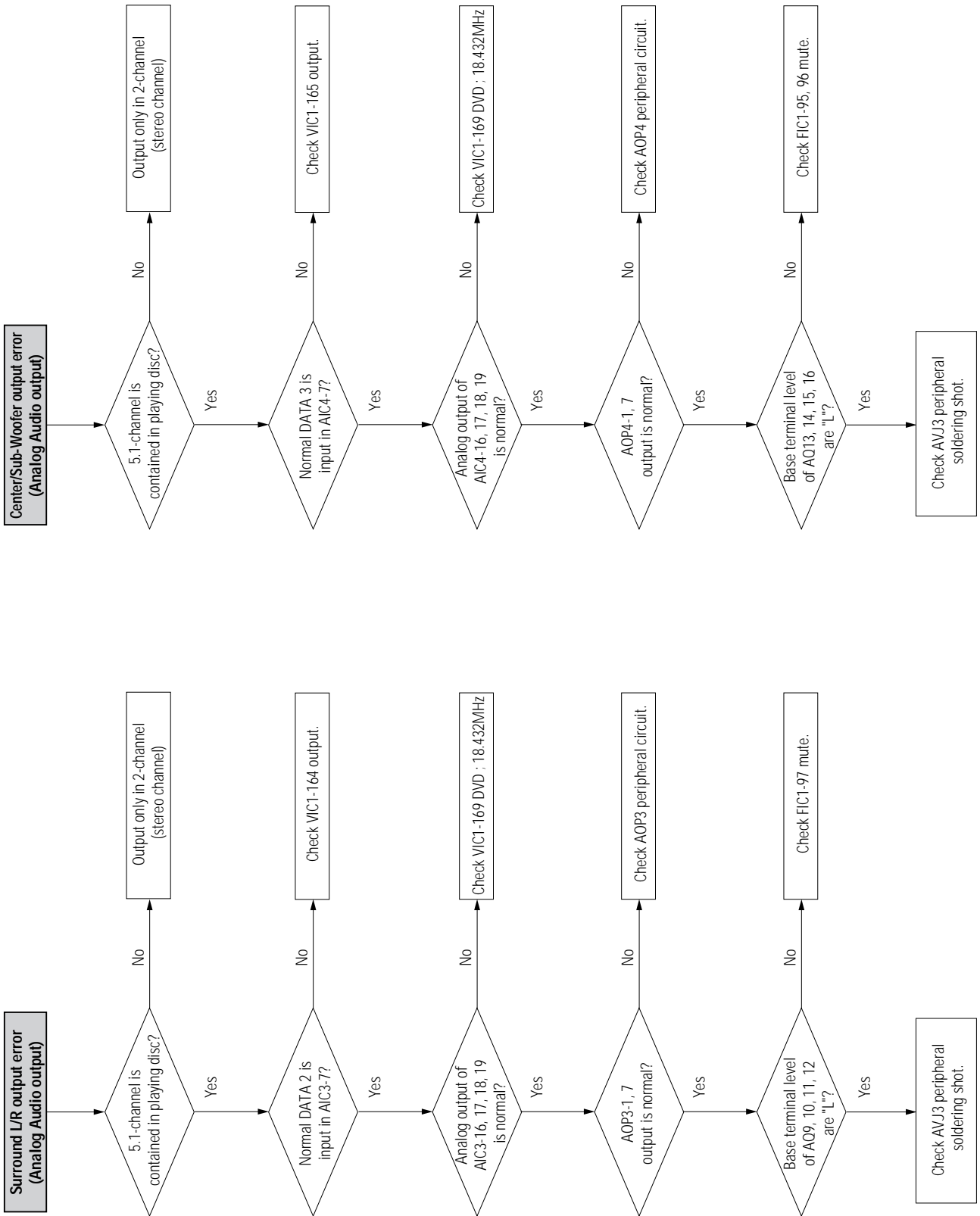

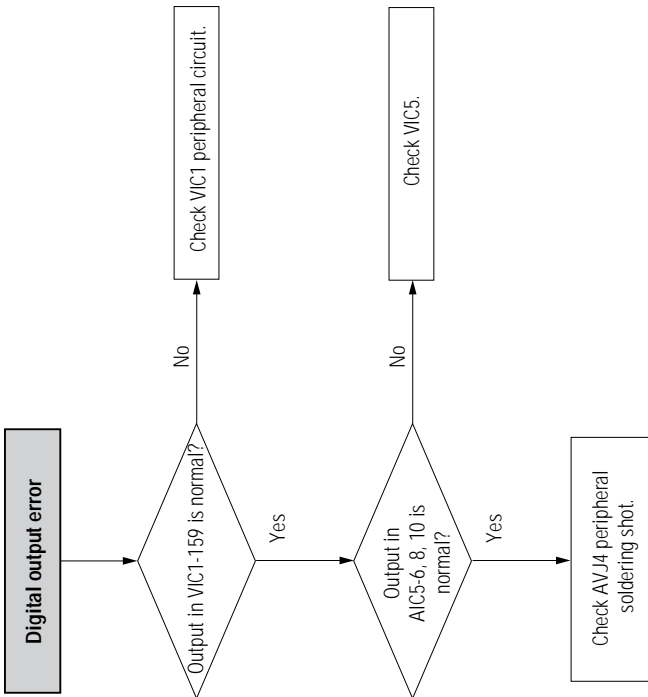
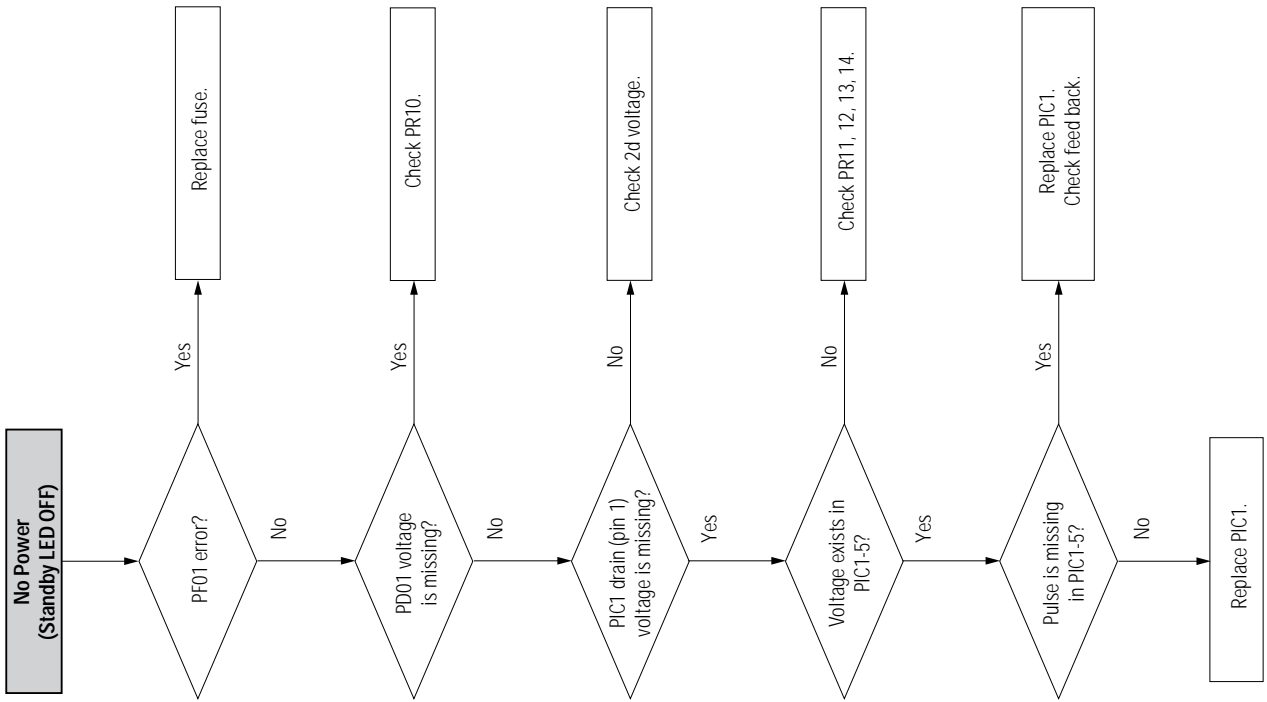

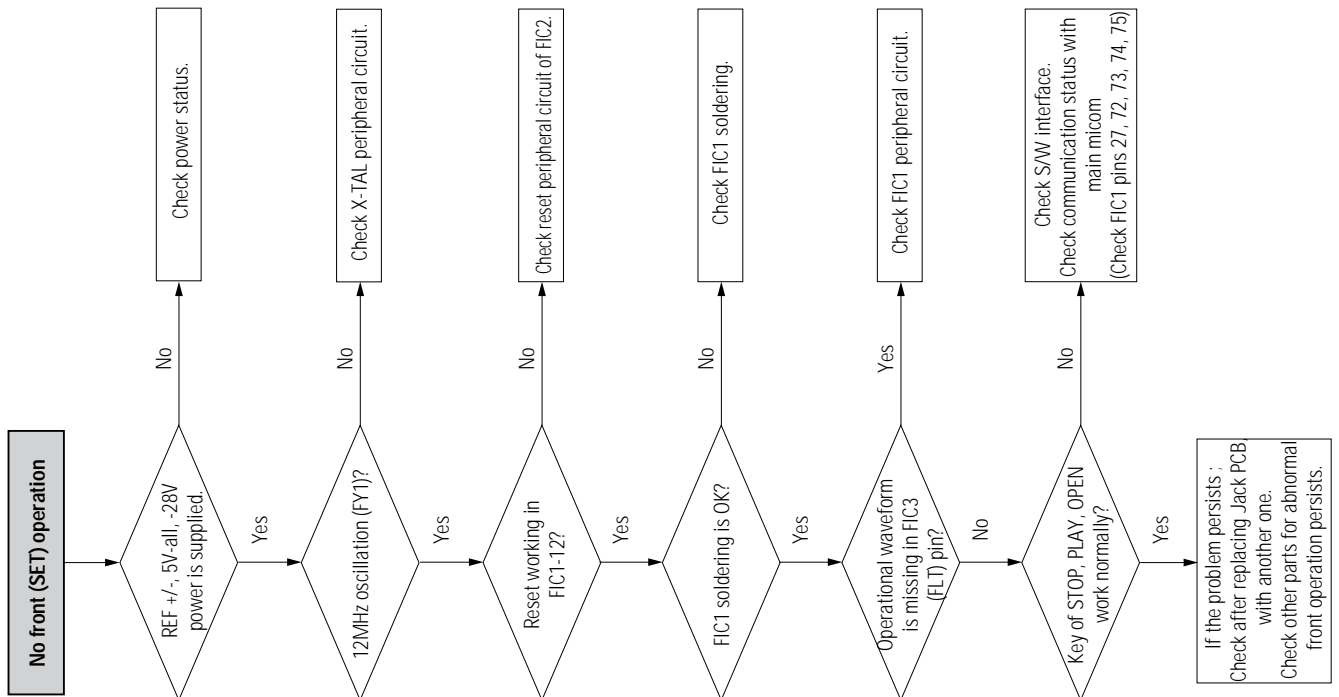
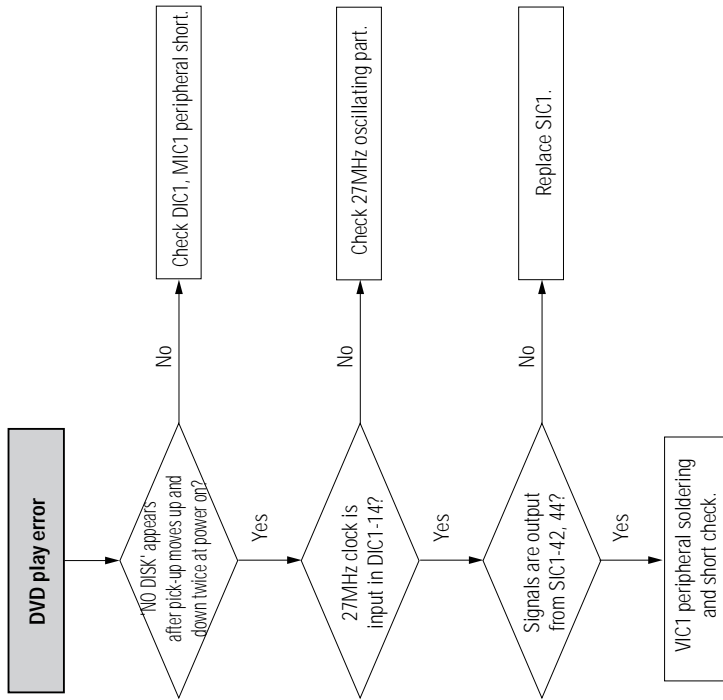

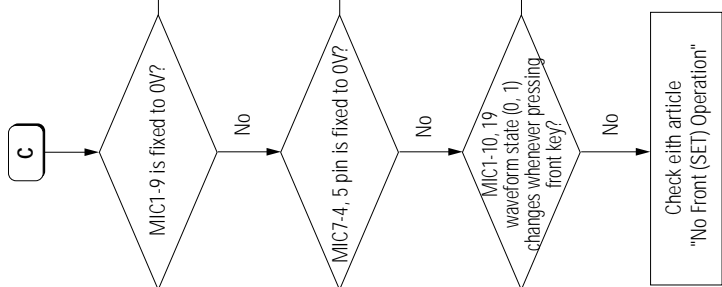
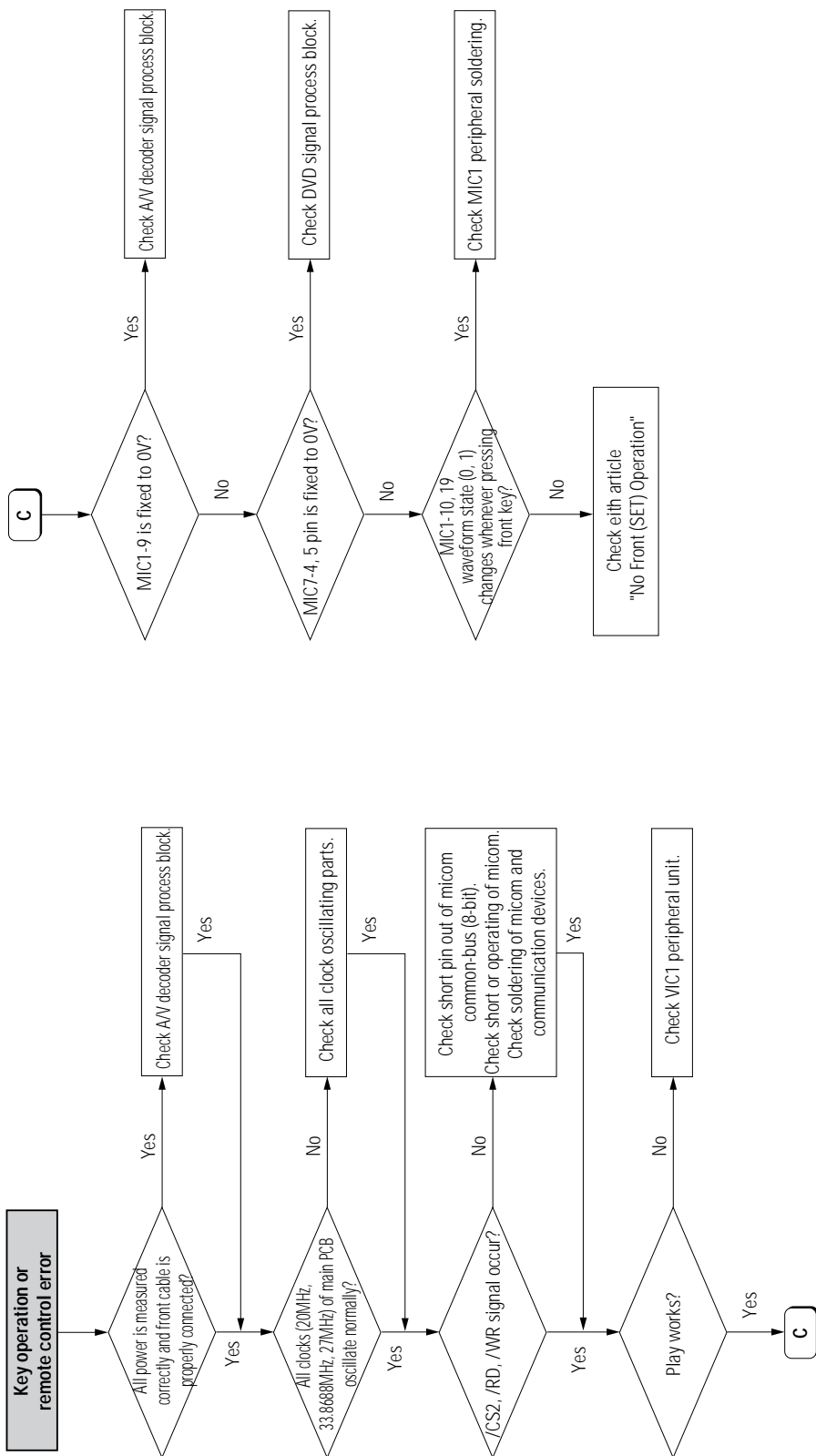

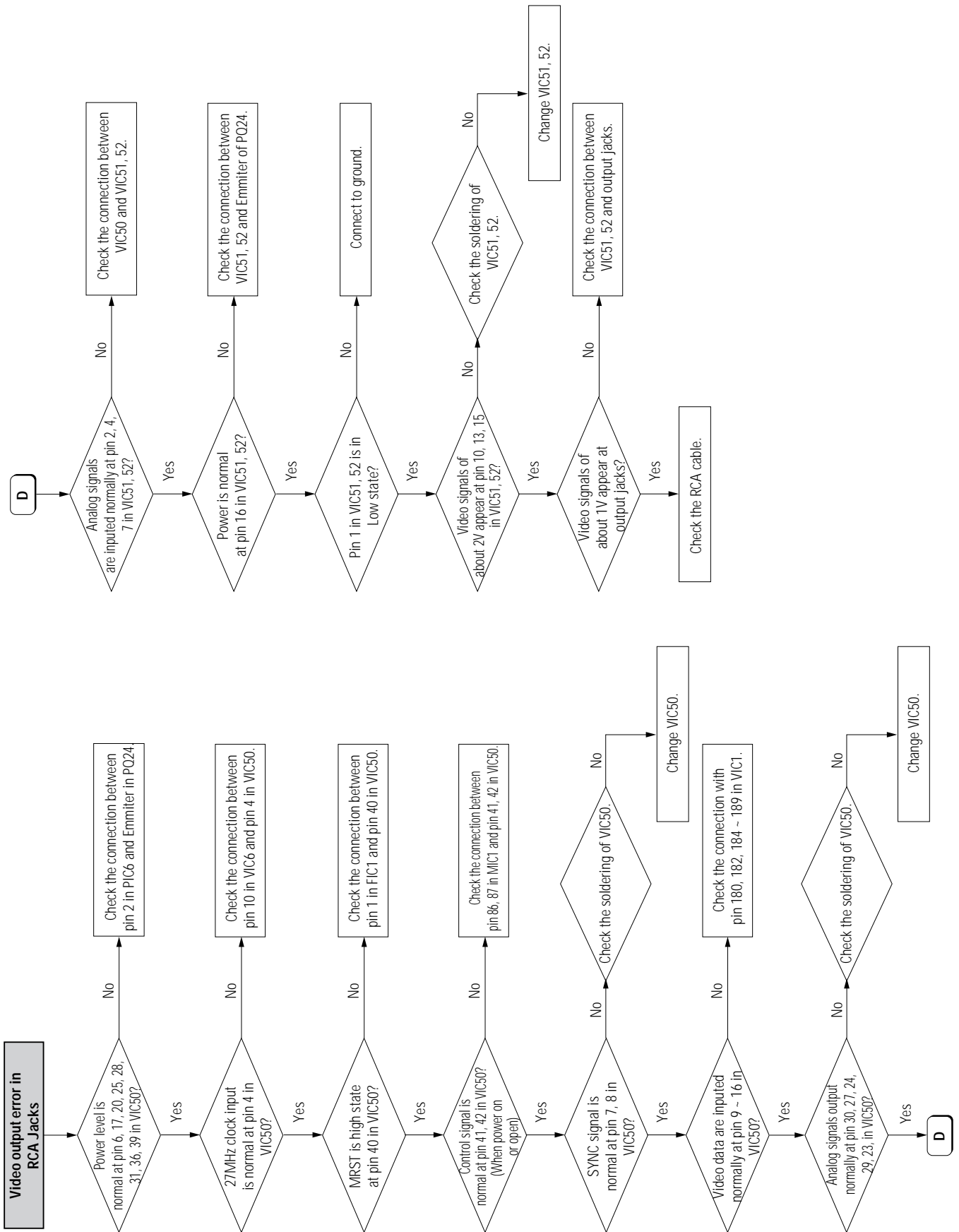

8. Exploded View and Parts List

	Page
8-1 Cabinet Assembly - - - - -	8-2
8-2 Deck Assembly - - - - -	8-4

8-1 Cabinet Assembly

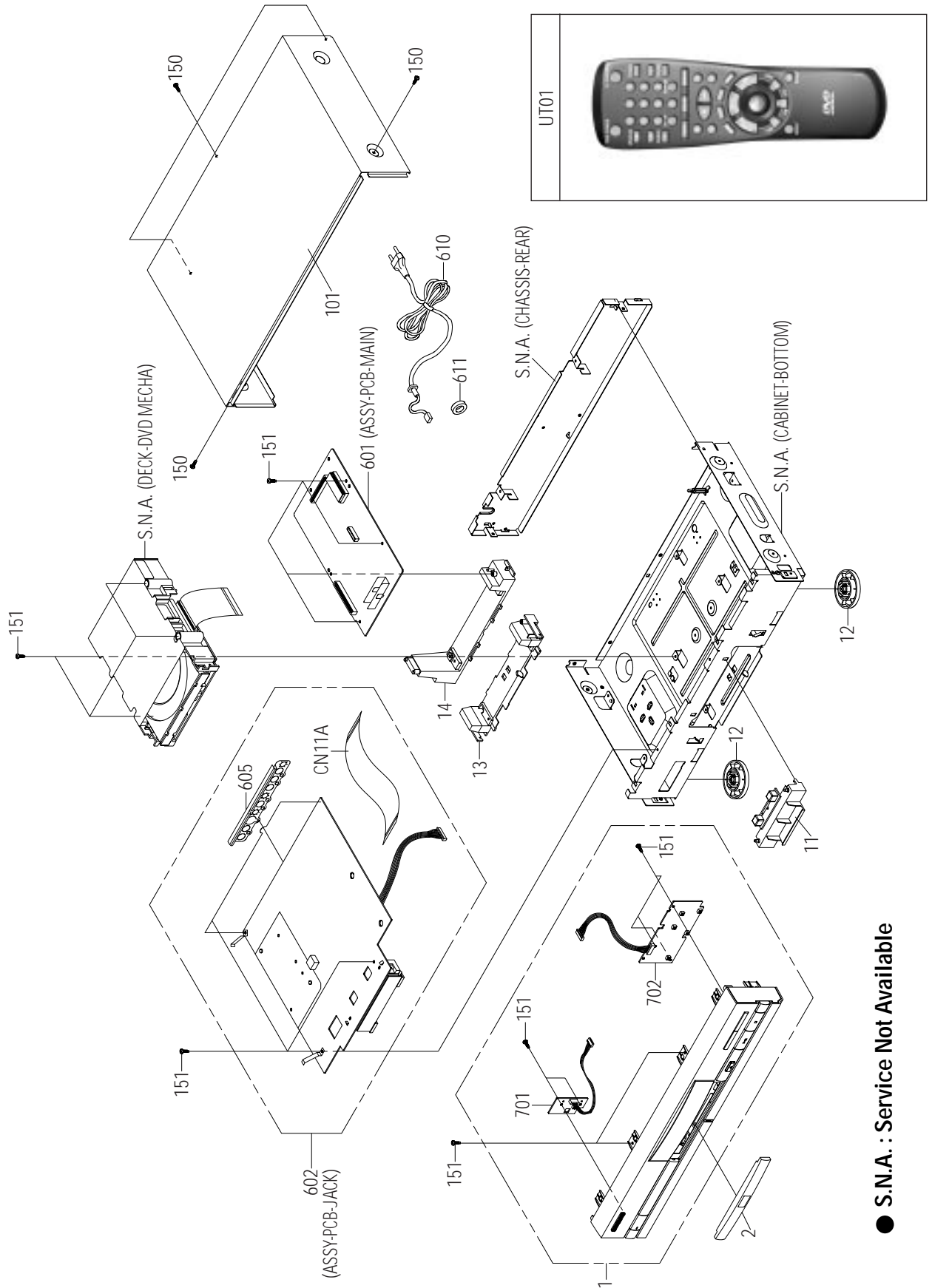

● S.N.A. : Service Not Available

Loc. No	Parts No.	Description ; Specification	Remark
1	AH95-10355E	ASSY-CABINET FRONT;DVD-739,ABS94HB,XAA	
2	AH95-50369E	ASSY-DOOR TRAY;DVD-739,ABS,XAA	
11	AH61-00194A	HOLDER-DECK A;- ,ABS 94HB,- ,BLK,- ,DVD-909	
12	AH64-80001E	FOOT-FRONT;- ,ABS94,HB,T2,SIL,H/STAMP,DVD	
13	AH61-00194B	HOLDER-DECK B;- ,ABS 94HB,- ,BLK,- ,DVD-909	
14	AH61-00194C	HOLDER-DECK C;- ,ABS 94HB,- ,BLK,- ,DVD-909	
150	6003-000275	SCREW-TAPTITE;BH,+ ,B,M3,L10,BLK,SWCH1018	
151	6003-000276	SCREW-TAPTITE;BH,+ ,B,M3,L10,ZPC(YEL),SWC	
101	AH97-00188D	ASSY-CABINET TOP;DVD-739,ASSY,XAA	
601	AH92-00172A	ASSY-PCB-MAIN;DVD-739,MAIN PCB	
602	AH92-00173A	ASSY-PCB-JACK;DVD-739,JACK PCB	
605	AH63-00040A	GROUND-REAR;- ,PBS,T0.2,- ,DVD-909	
610	AH39-00034A	POWER CORD;KJ-10W,EP2,- ,1.83M,CONNECTOR,	
611	3301-000132	CORE-FERRITE;AC,28.8x19.3x7.5mm,1400,290	
701	AH92-00167A	ASSY-PCB-POWER;DVD-709/DOM,POWER LEADER	
702	AH92-00166A	ASSY-PCB-PLAY;DVD-709/DOM,PLAY LEADER	
UT01	AH59-10141A	REMOCON-ASS'Y;- ,-, -,48,DVD-909,S.S	
CN11A	3809-001133	CABLE-FLAT;30V,80C,200MM,35P,1.25MM,UL28	

8-2 Deck Assembly

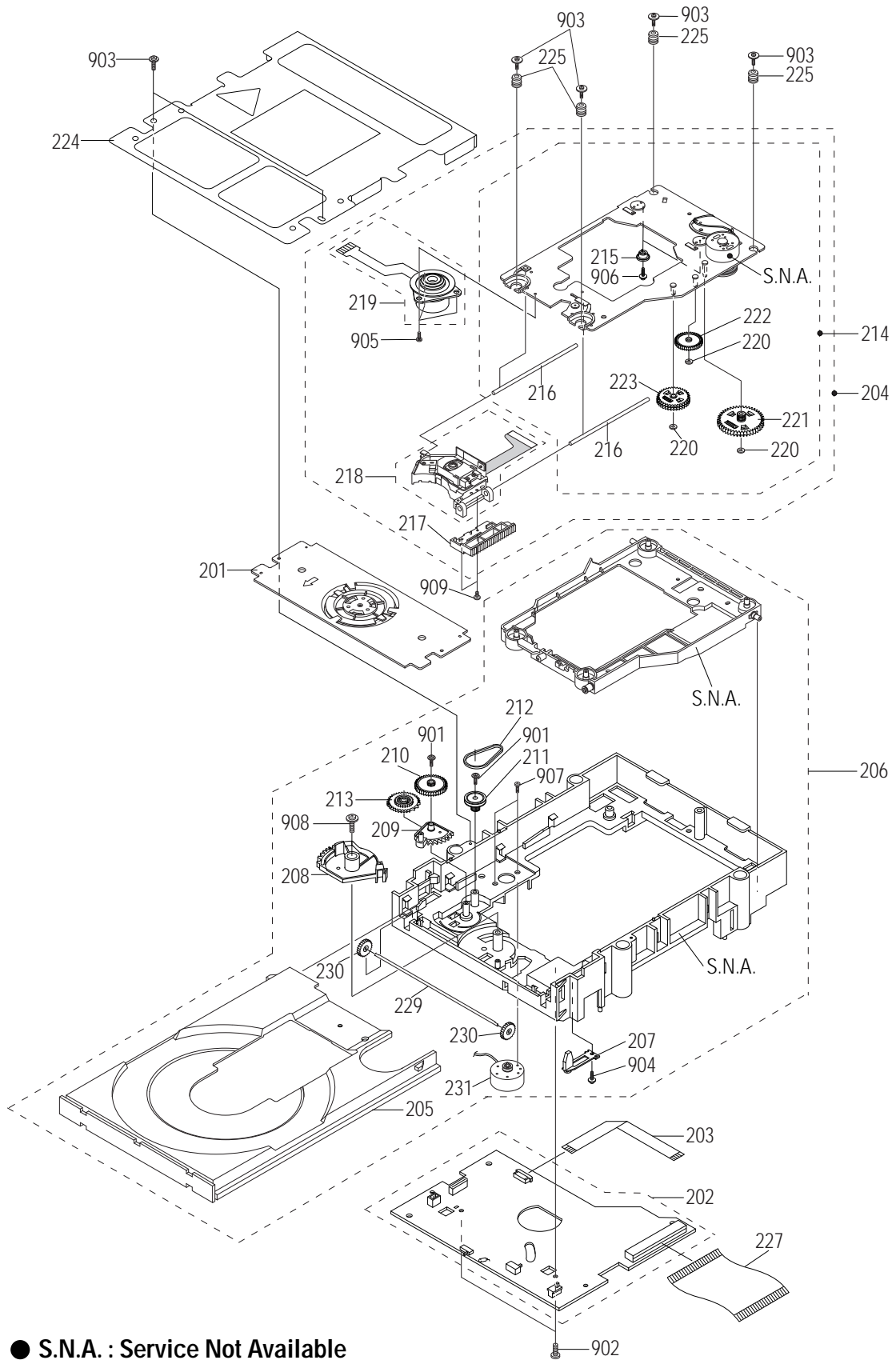

Loc. No	Parts No.	Description ; Specification	Remark
201	AH91-60117A	ASSY-DECK CLAMPER;DVD860,-,DP-1	
202	AH92-00035A	ASSY-PCB-DECK;DP-3,-	
203	3809-001125	CABLE-FLAT;30V,80C,140MM,8P,1MM,UL2896	
204	AH91-60147A	ASSY-BRKT DECK;DP-3,DVD-909,-	
205	AH66-90054A	TRAY-DVD;DP,ABS,-,BLK,-,DP-1	
206	AH91-60154A	ASSY-DECK HOUSING;DP-3,DVD-909,-	
207	AH66-30087A	LEVER-OPEN SW;DP,KEPITAL,T0.7,L26,F20-03	
208	AH66-20194A	GEAR-CAM CENTER;DP,KEPITAL F20-03,M1.2,Z	
209	AH66-20183A	GEAR-CAM SUB;DP,KEPITAL FT2020,M1,2,Z7,-	
210	AH66-20185A	GEAR-TRAY A;DP,KEPITAL F20-03,M0.4/M0.5,	
211	AH66-10024A	PULLEY-GEAR;DP,KEPITAL F20-03,BLK,DP-1	
212	AH66-60033A	BELT-PULLEY;DP,CR,T1.5,0.08,L82.7,BLK,DP	
213	AH66-20184A	GEAR-TRAY;DP,KEPITAL F20-03,M0.5/M0.6,Z4	
214	AH97-00178A	ASSY-BRKT FEED;DP-3,-,SOH-DP1	
215	BG61-20031A	HOLDER-CAM;- ,POM,-,-,-,DDR-4	
216	AH61-50327A	SHAFT-P/U;DP,SUS420J2,OD3,L84.7,S/FINISH	
217	AH66-20228A	RACK-SLIDE;DP,KEPITAL F20-03,WHT,M0.4,P1	
218	AH30-20001B	PICK-UP;SPU-DP1 DVD-909	
219	AH91-60151A	ASSY-MOTOR SPINDLE;DP-3,DVD-909,-	
220	AH60-30020A	WASHER-PLAIN;DP,-,ID3.1,OD6,T0.3,RED COL	
221	AH91-60120A	ASSY-GEAR-FEED-AU/AL;DP-1,DVD-860,-	
222	AH66-20182A	GEAR-FEED B;DP,KEPITAL F20-03,M0.4,Z44,W	
223	AH91-60121A	ASSY-GEAR-FEED-CU/CL;DP-1,DVD-860,-	
224	AH63-30245B	COVER-sheet;-,-,-,T0.7,CLR,-,BLK CARBON,	
225	AH73-10017A	RUBBER-INSULATOR;RUBBER(LB-40),OD11,DP-1	
227	3809-001123	CABLE-FLAT;30V,80C,90MM,40P,1.25MM,UL289	
229	AH61-50323A	SHAFT-SYNCRO;- ,sus304,2.1,119,-,-,dvd-90	
230	AH66-22005A	GEAR-SYNCRO-A;KEPITAL F20-03,M0.8,Z9,-,P	
231	AH97-00179A	ASSY-HOUSING MOTOR;DP-3,-,SOH-DP1	
901	AH60-10151A	SCREW-TAP TITE;DP,SPEC6.8 ,PH,+,CP,M2,L	
902	AC60-10051A	SCREW-TAPPING;BH,-,-,M3,L8,FZY	
903	AH60-10143U	SCREW-TAP TITE;DP,PH,+,SPEC,TAP1.7,L5,ZP	
904	AH60-10145A	SCREW-TAP TITE;DP,PH,+,SPEC OD5.5 FP,TAP	
905	AH60-10147A	SCREW-MACHINE;DP,CH,+,FP,M2,L4,ZPC,SWRCH	
906	AC60-10059A	SCREW-TAPPING;BH,+,-,1.7,X5,ZPC2	
907	AH60-00010A	SCREW-MACHINE-MOTOR;- ,+,SWCH18AK,M1.7,L2	
908	AC60-10042A	SCREW-TAPPING;PWH,+,-,M3,L8,-	
909	BG60-10020A	SCREW-SP MOTOR;- ,BHW TOOTH,-,-,M1.7,L3,-	

MEMO

9. Electrical Parts List

Loc.No	Part No	Description ; Specification	Remark	Loc.No	Part No	Description ; Specification	Remark
601		ASSY-PCB-MAIN;DVD-739		DRR11	2007-000087	R-CHIP:6.8Kohm,5%,1/16W,DA,TP,1608	
AR1	2007-000074	R-CHIP:100ohm,5%,1/16W,DA,TP,1608		DRR12	2007-000087	R-CHIP:6.8Kohm,5%,1/16W,DA,TP,1608	
AR2	2007-000074	R-CHIP:100ohm,5%,1/16W,DA,TP,1608		DRR13	2007-000090	R-CHIP:10Kohm,5%,1/16W,DA,TP,1608	
AR3	2007-000074	R-CHIP:100ohm,5%,1/16W,DA,TP,1608		DRR14	2007-000070	R-CHIP:0ohm,5%,1/16W,DA,TP,1608	
AR4	2007-000074	R-CHIP:100ohm,5%,1/16W,DA,TP,1608		DRR3	2007-007157	R-CHIP:1ohm,5%,1/4W,DA,TP,3216	
AR5	2007-000074	R-CHIP:100ohm,5%,1/16W,DA,TP,1608		DRR4	2007-007157	R-CHIP:1ohm,5%,1/4W,DA,TP,3216	
AR6	2007-000074	R-CHIP:100ohm,5%,1/16W,DA,TP,1608		DRR7	2007-001179	R-CHIP:8.2Kohm,5%,1/16W,DA,TP,1608	
AR7	2007-000070	R-CHIP:0ohm,5%,1/16W,DA,TP,1608		DRR9	2007-000616	R-CHIP:24Kohm,5%,1/16W,DA,TP,1608	
AR8	2007-000074	R-CHIP:100ohm,5%,1/16W,DA,TP,1608		MC1	2203-000189	C-CERAMIC,CHIP:100nF,+80-20%,25V,Y5V,TP,	
AR9	2007-000070	R-CHIP:0ohm,5%,1/16W,DA,TP,1608		MC10	2203-000189	C-CERAMIC,CHIP:100nF,+80-20%,25V,Y5V,TP,	
CN6	3708-001085	CONNECTOR-FPC/FC/PIC:40P,1.25mm,STRAIGHT		MC11	2203-000189	C-CERAMIC,CHIP:100nF,+80-20%,25V,Y5V,TP,	
CN7	3711-003358	CONNECTOR-HEADER:BOX,8P,1R,2.5mm,STRAIGHT		MC12	2203-000189	C-CERAMIC,CHIP:100nF,+80-20%,25V,Y5V,TP,	
CN8	3708-001364	CONNECTOR-FPC/FC/PIC:35P,1.25MM,STRAIGHT		MC13	2203-000189	C-CERAMIC,CHIP:100nF,+80-20%,25V,Y5V,TP,	
DC1	2203-000560	C-CERAMIC,CHIP:220nF,+80-20%,25V,Y5V,TP,		MC14	2203-000189	C-CERAMIC,CHIP:100nF,+80-20%,25V,Y5V,TP,	
DC10	2203-000189	C-CERAMIC,CHIP:100nF,+80-20%,25V,Y5V,TP,		MC16	2203-001656	C-CERAMIC,CHIP:470pF,5%,50V,CH,TP,1608,1	
DC11	2203-000189	C-CERAMIC,CHIP:100nF,+80-20%,25V,Y5V,TP,		MC18	2203-001656	C-CERAMIC,CHIP:470pF,5%,50V,CH,TP,1608,1	
DC12	2203-000189	C-CERAMIC,CHIP:100nF,+80-20%,25V,Y5V,TP,		MC19	2203-001656	C-CERAMIC,CHIP:470pF,5%,50V,CH,TP,1608,1	
DC13	2203-000189	C-CERAMIC,CHIP:100nF,+80-20%,25V,Y5V,TP,		MC2	2203-000189	C-CERAMIC,CHIP:100nF,+80-20%,25V,Y5V,TP,	
DC14	2203-000189	C-CERAMIC,CHIP:100nF,+80-20%,25V,Y5V,TP,		MC20	2203-000189	C-CERAMIC,CHIP:100nF,+80-20%,25V,Y5V,TP,	
DC15	2203-001567	C-CERAMIC,CHIP:10pF,0.5pF,50V,CH,TP,1608		MC3	2203-000426	C-CERAMIC,CHIP:18pF,5%,50V,NPO,1608,-,TP	
DC16	2203-000189	C-CERAMIC,CHIP:100nF,+80-20%,25V,Y5V,TP,		MC4	2203-000426	C-CERAMIC,CHIP:18pF,5%,50V,NPO,1608,-,TP	
DC2	2203-000560	C-CERAMIC,CHIP:220nF,+80-20%,25V,Y5V,TP,		MC5	2203-000189	C-CERAMIC,CHIP:100nF,+80-20%,25V,Y5V,TP,	
DC23	2203-000189	C-CERAMIC,CHIP:100nF,+80-20%,25V,Y5V,TP,		MC6	2203-000189	C-CERAMIC,CHIP:100nF,+80-20%,25V,Y5V,TP,	
DC24	2203-000189	C-CERAMIC,CHIP:100nF,+80-20%,25V,Y5V,TP,		MC7	2203-000189	C-CERAMIC,CHIP:100nF,+80-20%,25V,Y5V,TP,	
DC3	2203-000560	C-CERAMIC,CHIP:220nF,+80-20%,25V,Y5V,TP,		MC8	2203-000189	C-CERAMIC,CHIP:100nF,+80-20%,25V,Y5V,TP,	
DC4	2203-000189	C-CERAMIC,CHIP:100nF,+80-20%,25V,Y5V,TP,		MC9	2203-000189	C-CERAMIC,CHIP:100nF,+80-20%,25V,Y5V,TP,	
DC5	2203-000189	C-CERAMIC,CHIP:100nF,+80-20%,25V,Y5V,TP,		MIC1	0903-001144	IC-MICROCONTROLLER:93CM41,8BIT,QFP,100P,	
DC6	2203-000189	C-CERAMIC,CHIP:100nF,+80-20%,25V,Y5V,TP,		MIC2	0801-002207	IC-CMOS LOGIC:74AC573,LATCH,SOP,20P,300M	
DC7	2203-000189	C-CERAMIC,CHIP:100nF,+80-20%,25V,Y5V,TP,		MIC5	1103-001133	IC-EEPROM:24C020,256X8BIT,SOP,8P,150MIL,	
DC8	2203-000189	C-CERAMIC,CHIP:100nF,+80-20%,25V,Y5V,TP,		MIC6	0801-002143	IC-CMOS LOGIC:7S32,OR GATE,SOT-25,5P,63M	
DC9	2203-000189	C-CERAMIC,CHIP:100nF,+80-20%,25V,Y5V,TP,		MIC7	0801-000379	IC-CMOS LOGIC:74HC00,NAND GATE,SOP,14P,1	
DE1	2401-002144	C-AL:47uF,20%,16V,GP,TP,5x11,5		MIC8	1102-001090	IC-EPROM:27C081,1MX8BIT,DIP,32P,600MIL,1	
DIC1	AH13-10030P	IC-ASIC:-,KS1453,TOFP,128P,DATA PRO. I		MIC8A	3704-000472	SOCKET-IC:32P,DIP,SN,2.54mm	
DIC2	1105-001233	IC-DRAM:416C256,256KX16BIT,SOJ,40P,400MI		ML1	3301-000353	CORE-FERRITE BEAD:AB,2.0x1.25x0.9mm,-,-	
DIC7	0801-002097	IC-CMOS LOGIC:7SET08,AND GATE,SOP,5P,110		MQ1	0504-000128	TR-DIGITAL:-,NPN,200MW,22K/22K,SOT-23,TP	
DL1	3301-000353	CORE-FERRITE BEAD:AB,2.0x1.25x0.9mm,-,-		MR1	2007-000084	R-CHIP:4.7Kohm,5%,1/16W,DA,TP,1608	
DRC1	2203-000189	C-CERAMIC,CHIP:100nF,+80-20%,25V,Y5V,TP,		MR10	2007-000084	R-CHIP:4.7Kohm,5%,1/16W,DA,TP,1608	
DRC10	2203-000189	C-CERAMIC,CHIP:100nF,+80-20%,25V,Y5V,TP,		MR12	2007-000074	R-CHIP:100ohm,5%,1/16W,DA,TP,1608	
DRC11	2203-000189	C-CERAMIC,CHIP:100nF,+80-20%,25V,Y5V,TP,		MR13	2007-000074	R-CHIP:100ohm,5%,1/16W,DA,TP,1608	
DRC2	2203-000189	C-CERAMIC,CHIP:100nF,+80-20%,25V,Y5V,TP,		MR14	2007-000074	R-CHIP:100ohm,5%,1/16W,DA,TP,1608	
DRC3	2203-000189	C-CERAMIC,CHIP:100nF,+80-20%,25V,Y5V,TP,		MR15	2007-000074	R-CHIP:100ohm,5%,1/16W,DA,TP,1608	
DRC4	2203-000189	C-CERAMIC,CHIP:100nF,+80-20%,25V,Y5V,TP,		MR16	2007-000074	R-CHIP:100ohm,5%,1/16W,DA,TP,1608	
DRC5	2203-000189	C-CERAMIC,CHIP:100nF,+80-20%,25V,Y5V,TP,		MR17	2007-000074	R-CHIP:100ohm,5%,1/16W,DA,TP,1608	
DRC6	2203-000189	C-CERAMIC,CHIP:100nF,+80-20%,25V,Y5V,TP,		MR18	2007-000074	R-CHIP:100ohm,5%,1/16W,DA,TP,1608	
DRC7	2203-000189	C-CERAMIC,CHIP:100nF,+80-20%,25V,Y5V,TP,		MR19	2007-000074	R-CHIP:100ohm,5%,1/16W,DA,TP,1608	
DRC8	2203-000189	C-CERAMIC,CHIP:100nF,+80-20%,25V,Y5V,TP,		MR2	2007-000109	R-CHIP:1Mohm,5%,1/16W,DA,TP,1608	
DRC9	2203-000189	C-CERAMIC,CHIP:100nF,+80-20%,25V,Y5V,TP,		MR22	2007-000074	R-CHIP:100ohm,5%,1/16W,DA,TP,1608	
DRE1	2401-002075	C-AL:4.7uF,20%,50V,GP,TP,5x11,5		MR23	2007-000074	R-CHIP:100ohm,5%,1/16W,DA,TP,1608	
DRE2	2401-002075	C-AL:4.7uF,20%,50V,GP,TP,5x11,5		MR24	2007-000074	R-CHIP:100ohm,5%,1/16W,DA,TP,1608	
DRE3	2401-002075	C-AL:4.7uF,20%,50V,GP,TP,5x11,5		MR25	2007-000070	R-CHIP:0ohm,5%,1/16W,DA,TP,1608	
DRE4	2401-002144	C-AL:47uF,20%,16V,GP,TP,5x11,5		MR3	2007-000084	R-CHIP:4.7Kohm,5%,1/16W,DA,TP,1608	
DRE5	2401-002144	C-AL:47uF,20%,16V,GP,TP,5x11,5		MR33	2007-000070	R-CHIP:0ohm,5%,1/16W,DA,TP,1608	
DRE6	2401-002144	C-AL:47uF,20%,16V,GP,TP,5x11,5		MR34	2007-000084	R-CHIP:4.7Kohm,5%,1/16W,DA,TP,1608	
DRE7	2401-002144	C-AL:47uF,20%,16V,GP,TP,5x11,5		MR35	2007-000084	R-CHIP:4.7Kohm,5%,1/16W,DA,TP,1608	
DRE8	2401-002144	C-AL:47uF,20%,16V,GP,TP,5x11,5		MR36	2007-000124	R-CHIP:2.2Kohm,5%,1/16W,DA,TP,1608	
DRE9	2401-002144	C-AL:47uF,20%,16V,GP,TP,5x11,5		MR37	2007-000090	R-CHIP:10Kohm,5%,1/16W,DA,TP,1608	
DRIC1	1003-001130	IC-MOTOR DRIVER:KA3011DTF,SOP,28P,-,QUAD		MR38	2007-000090	R-CHIP:10Kohm,5%,1/16W,DA,TP,1608	
DRIC2	1003-001067	IC-MOTOR DRIVER:KA3010D,SOP,28P,375MIL,Q		MR39	2007-000103	R-CHIP:120Kohm,5%,1/16W,DA,TP,1608	
DRL1	3301-000353	CORE-FERRITE BEAD:AB,2.0x1.25x0.9mm,-,-		MR4	2007-000084	R-CHIP:4.7Kohm,5%,1/16W,DA,TP,1608	
DRL2	3301-000353	CORE-FERRITE BEAD:AB,2.0x1.25x0.9mm,-,-		MR40	2007-000402	R-CHIP:150ohm,5%,1/16W,DA,TP,1608	
DRR10	2007-000084	R-CHIP:4.7Kohm,5%,1/16W,DA,TP,1608		MR43	2007-000102	R-CHIP:100Kohm,5%,1/16W,DA,TP,1608	
				MR5	2007-000084	R-CHIP:4.7Kohm,5%,1/16W,DA,TP,1608	

Electrical Parts List

Loc.No	Part No	Description ; Specification	Remark
MR6	2007-000084	R-CHIP:4.7Kohm,5%,1/16W,DA,TP,1608	
MR7	2007-000084	R-CHIP:4.7Kohm,5%,1/16W,DA,TP,1608	
MR8	2007-000084	R-CHIP:4.7Kohm,5%,1/16W,DA,TP,1608	
MR9	2007-000084	R-CHIP:4.7Kohm,5%,1/16W,DA,TP,1608	
MXTAL1	2801-000199	CRYSTAL-UNIT:20MHz,50ppm,28-AAA,16pF,50o	
PC1	2203-000189	C-CERAMIC,CHIP:100nF,+80-20%,25V,Y5V,TP,	
PC2	2203-000189	C-CERAMIC,CHIP:100nF,+80-20%,25V,Y5V,TP,	
PC3	2203-000189	C-CERAMIC,CHIP:100nF,+80-20%,25V,Y5V,TP,	
PC4	2203-000189	C-CERAMIC,CHIP:100nF,+80-20%,25V,Y5V,TP,	
PE1	2401-002165	C-AL:100uF,20%,16V,GP,TP,6.3x7,5	
PE2	2401-002165	C-AL:100uF,20%,16V,GP,TP,6.3x7,5	
PE3	2401-002165	C-AL:100uF,20%,16V,GP,TP,6.3x7,5	
PE4	2401-002165	C-AL:100uF,20%,16V,GP,TP,6.3x7,5	
RC1	2203-000189	C-CERAMIC,CHIP:100nF,+80-20%,25V,Y5V,TP,	
RC10	2203-000257	C-CERAMIC,CHIP:10nF,10%,50V,X7R,TP,1608,	
RC11	2203-000189	C-CERAMIC,CHIP:100nF,+80-20%,25V,Y5V,TP,	
RC12	2203-000560	C-CERAMIC,CHIP:220nF,+80-20%,25V,Y5V,TP,	
RC13	2203-000560	C-CERAMIC,CHIP:220nF,+80-20%,25V,Y5V,TP,	
RC14	2203-000440	C-CERAMIC,CHIP:1nF,10%,50V,X7R,TP,1608,-	
RC15	2203-000189	C-CERAMIC,CHIP:100nF,+80-20%,25V,Y5V,TP,	
RC16	2203-000189	C-CERAMIC,CHIP:100nF,+80-20%,25V,Y5V,TP,	
RC17	2203-000189	C-CERAMIC,CHIP:100nF,+80-20%,25V,Y5V,TP,	
RC2	2203-000189	C-CERAMIC,CHIP:100nF,+80-20%,25V,Y5V,TP,	
RC20	2203-000189	C-CERAMIC,CHIP:100nF,+80-20%,25V,Y5V,TP,	
RC21	2203-000384	C-CERAMIC,CHIP:.015NF,5%,50V,NPO,TP,1608	
RC22	2203-000189	C-CERAMIC,CHIP:100nF,+80-20%,25V,Y5V,TP,	
RC23	2203-000189	C-CERAMIC,CHIP:100nF,+80-20%,25V,Y5V,TP,	
RC24	2203-001697	C-CERAMIC,CHIP:.082NF,5%,50V,NPO,TP,1608	
RC25	2203-000189	C-CERAMIC,CHIP:100nF,+80-20%,25V,Y5V,TP,	
RC26	2203-000189	C-CERAMIC,CHIP:100nF,+80-20%,25V,Y5V,TP,	
RC27	2203-000189	C-CERAMIC,CHIP:100nF,+80-20%,25V,Y5V,TP,	
RC28	2203-001052	C-CERAMIC,CHIP:.56NF,10%,50V,X7R,TP,1608	
RC29	2203-000189	C-CERAMIC,CHIP:100nF,+80-20%,25V,Y5V,TP,	
RC3	2203-000189	C-CERAMIC,CHIP:100nF,+80-20%,25V,Y5V,TP,	
RC31	2203-000189	C-CERAMIC,CHIP:100nF,+80-20%,25V,Y5V,TP,	
RC32	2203-000189	C-CERAMIC,CHIP:100nF,+80-20%,25V,Y5V,TP,	
RC33	2203-000189	C-CERAMIC,CHIP:100nF,+80-20%,25V,Y5V,TP,	
RC34	2203-000189	C-CERAMIC,CHIP:100nF,+80-20%,25V,Y5V,TP,	
RC35	2203-000236	C-CERAMIC,CHIP:100pF,5%,50V,NPO,TP,1608,	
RC36	2203-000140	C-CERAMIC,CHIP:1.5nF,10%,50V,X7R,TP,1608	
RC37	2203-000189	C-CERAMIC,CHIP:100nF,+80-20%,25V,Y5V,TP,	
RC38	2203-000189	C-CERAMIC,CHIP:100nF,+80-20%,25V,Y5V,TP,	
RC39	2203-000531	C-CERAMIC,CHIP:2.7nF,10%,50V,X7R,TP,1608	
RC4	2203-000236	C-CERAMIC,CHIP:100pF,5%,50V,NPO,TP,1608,	
RC40	2203-000257	C-CERAMIC,CHIP:10nF,10%,50V,X7R,TP,1608,	
RC41	2203-000189	C-CERAMIC,CHIP:100nF,+80-20%,25V,Y5V,TP,	
RC42	2203-000189	C-CERAMIC,CHIP:100nF,+80-20%,25V,Y5V,TP,	
RC43	2203-000189	C-CERAMIC,CHIP:100nF,+80-20%,25V,Y5V,TP,	
RC44	2203-000189	C-CERAMIC,CHIP:100nF,+80-20%,25V,Y5V,TP,	
RC45	2203-001652	C-CERAMIC,CHIP:470NF,+80-20%,16V,Y5V,TP,	
RC46	2203-000560	C-CERAMIC,CHIP:220nF,+80-20%,25V,Y5V,TP,	
RC47	2203-000189	C-CERAMIC,CHIP:100nF,+80-20%,25V,Y5V,TP,	
RC5	2203-000189	C-CERAMIC,CHIP:100nF,+80-20%,25V,Y5V,TP,	
RC50	2203-000189	C-CERAMIC,CHIP:100nF,+80-20%,25V,Y5V,TP,	
RC51	2203-000189	C-CERAMIC,CHIP:100nF,+80-20%,25V,Y5V,TP,	
RC52	2203-000189	C-CERAMIC,CHIP:100nF,+80-20%,25V,Y5V,TP,	
RC53	2203-000189	C-CERAMIC,CHIP:100nF,+80-20%,25V,Y5V,TP,	
RC54	2203-000189	C-CERAMIC,CHIP:100nF,+80-20%,25V,Y5V,TP,	
RC55	2203-000888	C-CERAMIC,CHIP:4.7nF,10%,50V,X7R,TP,1608	
RC6	2203-001052	C-CERAMIC,CHIP:.56NF,10%,50V,X7R,TP,1608	
RC7	2203-001640	C-CERAMIC,CHIP:390pF,10%,50V,X7R,TP,1608	
RC8	2203-000384	C-CERAMIC,CHIP:.015NF,5%,50V,NPO,TP,1608	
RC9	2203-000257	C-CERAMIC,CHIP:10nF,10%,50V,X7R,TP,1608,	
RD1	0401-000008	DIODE-SWITCHING:DAN217,80V,100mA,SOT-23,	
RD2	0403-001079	DIODE-ZENER:UDZ3.9B,7%,200MW,SOD-323,TP	
RD6	0407-000114	DIODE-ARRAY:DAN202K,80V,100mA,CA2-3,SOT-	

Loc.No	Part No	Description ; Specification	Remark
RD7	0407-000114	DIODE-ARRAY:DAN202K,80V,100mA,CA2-3,SOT-	
RE10	2401-002036	C-AL:1uF,20%,50V,GP,TP,5x11,2.5mm	
RE11	2401-000913	C-AL:22uF,20%,16V,GP,TP,5x11mm,2.5mm	
RE12	2401-002144	C-AL:47uF,20%,16V,GP,TP,5x11,5	
RE13	2401-000414	C-AL:10uF,20%,16V,GP,TP,4x7,5	
RE17	2401-002144	C-AL:47uF,20%,16V,GP,TP,5x11,5	
RE2	2401-000414	C-AL:10uF,20%,16V,GP,TP,4x7,5	
RE8	2401-000414	C-AL:10uF,20%,16V,GP,TP,4x7,5	
RE9	2401-002144	C-AL:47uF,20%,16V,GP,TP,5x11,5	
RIC1	AH13-10030M	IC-ASIC:-,KS1461,VQFP,100P,RF IC	
RIC2	0801-002279	IC-CMOS LOGIC:74VHC4053,MUX,SOP,16P,150M	
RIC3	1202-000121	IC-VOLTAGE COMP:2903,SOP8P,150MIL,DUAL	
RIC4	1201-000163	IC-OP AMP:4560,SOP8P,150MIL,DUAL,100V/M	
RIC6	0801-002097	IC-CMOS LOGIC:7SET08,AND GATE,SOP,5P,110	
RL2	2703-000398	INDUCTOR-SMD:10UH,10%,3.2X2.5X2.2MM	
RL3	3301-000353	CORE-FERRITE BEAD:AB,2.0x1.25x0.9mm,-,-	
RL4	3301-000353	CORE-FERRITE BEAD:AB,2.0x1.25x0.9mm,-,-	
RQ1	0501-000279	TR-SMALL SIGNAL:KSA1182-Y,PNP,150mW,SOT-	
RQ2	0504-000128	TR-DIGITAL:-,NPN,200MW,22K/22K,SOT-23,TP	
RR1	2007-000091	R-CHIP:12Kohm,5%,1/16W,DA,TP,1608	
RR10	2007-001179	R-CHIP:8.2Kohm,5%,1/16W,DA,TP,1608	
RR11	2007-000509	R-CHIP:2.4Kohm,1%,1/16W,DA,TP,1608	
RR12	2007-000093	R-CHIP:20Kohm,5%,1/16W,DA,TP,1608	
RR13	2007-001179	R-CHIP:8.2Kohm,5%,1/16W,DA,TP,1608	
RR14	2007-000091	R-CHIP:12Kohm,5%,1/16W,DA,TP,1608	
RR15	2007-001179	R-CHIP:8.2Kohm,5%,1/16W,DA,TP,1608	
RR16	2007-000704	R-CHIP:3.6Kohm,5%,1/16W,DA,TP,1608	
RR17	2007-000092	R-CHIP:15Kohm,5%,1/16W,DA,TP,1608	
RR18	2007-000102	R-CHIP:100Kohm,5%,1/16W,DA,TP,1608	
RR19	2007-000102	R-CHIP:100Kohm,5%,1/16W,DA,TP,1608	
RR2	2007-000092	R-CHIP:15Kohm,5%,1/16W,DA,TP,1608	
RR20	2007-000084	R-CHIP:4.7Kohm,5%,1/16W,DA,TP,1608	
RR21	2007-000081	R-CHIP:2.7Kohm,5%,1/16W,DA,TP,1608	
RR22	2007-000102	R-CHIP:100Kohm,5%,1/16W,DA,TP,1608	
RR23	2007-000102	R-CHIP:100Kohm,5%,1/16W,DA,TP,1608	
RR24	2007-000078	R-CHIP:1Kohm,5%,1/16W,DA,TP,1608	
RR25	2007-000091	R-CHIP:12Kohm,5%,1/16W,DA,TP,1608	
RR26	2007-000090	R-CHIP:10Kohm,5%,1/16W,DA,TP,1608	
RR27	2007-000130	R-CHIP:39Kohm,5%,1/16W,DA,TP,1608	
RR28	2007-000078	R-CHIP:1Kohm,5%,1/16W,DA,TP,1608	
RR29	2007-000078	R-CHIP:1Kohm,5%,1/16W,DA,TP,1608	
RR3	2007-000091	R-CHIP:12Kohm,5%,1/16W,DA,TP,1608	
RR30	2007-000091	R-CHIP:12Kohm,5%,1/16W,DA,TP,1608	
RR31	2007-001179	R-CHIP:8.2Kohm,5%,1/16W,DA,TP,1608	
RR32	2007-000102	R-CHIP:100Kohm,5%,1/16W,DA,TP,1608	
RR32A	2007-000108	R-CHIP:510Kohm,5%,1/16W,DA,TP,1608	
RR33	2007-000082	R-CHIP:3.3Kohm,5%,1/16W,DA,TP,1608	
RR34	2007-000090	R-CHIP:10Kohm,5%,1/16W,DA,TP,1608	
RR35	2007-000092	R-CHIP:15Kohm,5%,1/16W,DA,TP,1608	
RR36	2007-000102	R-CHIP:100Kohm,5%,1/16W,DA,TP,1608	
RR37	2007-000102	R-CHIP:100Kohm,5%,1/16W,DA,TP,1608	
RR38	2007-000102	R-CHIP:100Kohm,5%,1/16W,DA,TP,1608	
RR39	2007-000102	R-CHIP:100Kohm,5%,1/16W,DA,TP,1608	
RR4	2007-000090	R-CHIP:10Kohm,5%,1/16W,DA,TP,1608	
RR40	2007-000655	R-CHIP:27Kohm,5%,1/16W,DA,TP,1608	
RR41	2007-000708	R-CHIP:3.9Kohm,1%,1/16W,DA,TP,1608	
RR42	2007-000090	R-CHIP:10Kohm,5%,1/16W,DA,TP,1608	
RR43	2007-000090	R-CHIP:10Kohm,5%,1/16W,DA,TP,1608	
RR44	2007-000090	R-CHIP:10Kohm,5%,1/16W,DA,TP,1608	
RR45	2007-000090	R-CHIP:10Kohm,5%,1/16W,DA,TP,1608	
RR46	2007-000084	R-CHIP:4.7Kohm,5%,1/16W,DA,TP,1608	
RR47	2007-000102	R-CHIP:100Kohm,5%,1/16W,DA,TP,1608	
RR48	2007-000102	R-CHIP:100Kohm,5%,1/16W,DA,TP,1608	
RR49	2007-000084	R-CHIP:4.7Kohm,5%,1/16W,DA,TP,1608	
RR5	2007-001056	R-CHIP:6.2Kohm,5%,1/16W,DA,TP,1608	
RR50	2007-000084	R-CHIP:4.7Kohm,5%,1/16W,DA,TP,1608	

Loc.No	Part No	Description ; Specification	Remark	Loc.No	Part No	Description ; Specification	Remark
RR51	2007-000134	R-CHIP:33Kohm,5%,1/16W,DA,TP,1608		SR10	2007-000084	R-CHIP:4.7Kohm,5%,1/16W,DA,TP,1608	
RR52	2007-000084	R-CHIP:4.7Kohm,5%,1/16W,DA,TP,1608		SR11	2007-000107	R-CHIP:470Kohm,5%,1/16W,DA,TP,1608	
RR53	2007-001179	R-CHIP:8.2Kohm,5%,1/16W,DA,TP,1608		SR12	2007-001235	R-CHIP:910Kohm,5%,1/16W,DA,TP,1608	
RR53A	2007-000087	R-CHIP:6.8Kohm,5%,1/16W,DA,TP,1608		SR13	2007-000070	R-CHIP:0ohm,5%,1/16W,DA,TP,1608	
RR56	2007-000084	R-CHIP:4.7Kohm,5%,1/16W,DA,TP,1608		SR14	2007-000450	R-CHIP:180ohm,5%,1/16W,DA,TP,1608	
RR57	2007-000088	R-CHIP:7.5Kohm,5%,1/16W,DA,TP,1608		SR15	2007-000102	R-CHIP:100Kohm,5%,1/16W,DA,TP,1608	
RR58	2007-000091	R-CHIP:12Kohm,5%,1/16W,DA,TP,1608		SR16	2007-000131	R-CHIP:91Kohm,5%,1/16W,DA,TP,1608	
RR59	2007-000082	R-CHIP:3.3Kohm,5%,1/16W,DA,TP,1608		SR17	2007-000093	R-CHIP:20Kohm,5%,1/16W,DA,TP,1608	
RR6	2007-000092	R-CHIP:15Kohm,5%,1/16W,DA,TP,1608		SR18	2007-000093	R-CHIP:20Kohm,5%,1/16W,DA,TP,1608	
RR62	2007-000084	R-CHIP:4.7Kohm,5%,1/16W,DA,TP,1608		SR19	2007-000092	R-CHIP:15Kohm,5%,1/16W,DA,TP,1608	
RR63	2007-000090	R-CHIP:10Kohm,5%,1/16W,DA,TP,1608		SR2	2007-000109	R-CHIP:1Mohm,5%,1/16W,DA,TP,1608	
RR65	2007-000082	R-CHIP:3.3Kohm,5%,1/16W,DA,TP,1608		SR20	2007-000092	R-CHIP:15Kohm,5%,1/16W,DA,TP,1608	
RR67	2007-000092	R-CHIP:15Kohm,5%,1/16W,DA,TP,1608		SR21	2007-000070	R-CHIP:0ohm,5%,1/16W,DA,TP,1608	
RR68	2007-000655	R-CHIP:27Kohm,5%,1/16W,DA,TP,1608		SR22	2007-000070	R-CHIP:0ohm,5%,1/16W,DA,TP,1608	
RR69	2007-000091	R-CHIP:12Kohm,5%,1/16W,DA,TP,1608		SR23	2007-000130	R-CHIP:39Kohm,5%,1/16W,DA,TP,1608	
RR69A	2007-000431	R-CHIP:16Kohm,5%,1/16W,DA,TP,1608		SR24	2007-000070	R-CHIP:0ohm,5%,1/16W,DA,TP,1608	
RR7	2007-000072	R-CHIP:47ohm,5%,1/16W,DA,TP,1608		SR26	2007-000091	R-CHIP:12Kohm,5%,1/16W,DA,TP,1608	
RR70	2007-000134	R-CHIP:33Kohm,5%,1/16W,DA,TP,1608		SR3	2007-000090	R-CHIP:10Kohm,5%,1/16W,DA,TP,1608	
RR71	2007-000070	R-CHIP:0ohm,5%,1/16W,DA,TP,1608		SR31	2007-000080	R-CHIP:2Kohm,5%,1/16W,DA,TP,1608	
RR8	2007-000077	R-CHIP:470ohm,5%,1/16W,DA,TP,1608		SR32	2007-000080	R-CHIP:2Kohm,5%,1/16W,DA,TP,1608	
RR9	2007-000783	R-CHIP:330HM,5%,1/8W,DA,TP,3216		SR33	2007-000080	R-CHIP:2Kohm,5%,1/16W,DA,TP,1608	
SC1	2203-000189	C-CERAMIC,CHIP:100nF,+80-20%,25V,Y5V,TP,		SR34	2007-000124	R-CHIP:2.2Kohm,5%,1/16W,DA,TP,1608	
SC10	2203-001222	C-CERAMIC,CHIP:820pF,10%,50V,X7R,TP,1608		SR35	2007-000124	R-CHIP:2.2Kohm,5%,1/16W,DA,TP,1608	
SC11	2203-000189	C-CERAMIC,CHIP:100nF,+80-20%,25V,Y5V,TP,		SR36	2007-000124	R-CHIP:2.2Kohm,5%,1/16W,DA,TP,1608	
SC14	2203-000491	C-CERAMIC,CHIP:2.2nF,10%,50V,X7R,TP,1608		SR37	2007-000124	R-CHIP:2.2Kohm,5%,1/16W,DA,TP,1608	
SC15	2203-000491	C-CERAMIC,CHIP:2.2nF,10%,50V,X7R,TP,1608		SR38	2007-000092	R-CHIP:15Kohm,5%,1/16W,DA,TP,1608	
SC16	2203-000189	C-CERAMIC,CHIP:100nF,+80-20%,25V,Y5V,TP,		SR39	2007-000458	R-CHIP:18Kohm,5%,1/16W,DA,TP,1608	
SC17	2203-000560	C-CERAMIC,CHIP:220nF,+80-20%,25V,Y5V,TP,		SR4	2007-001179	R-CHIP:8.2Kohm,5%,1/16W,DA,TP,1608	
SC18	2203-000189	C-CERAMIC,CHIP:100nF,+80-20%,25V,Y5V,TP,		SR40	2007-000090	R-CHIP:10Kohm,5%,1/16W,DA,TP,1608	
SC19	2203-000140	C-CERAMIC,CHIP:1.5nF,10%,50V,X7R,TP,1608		SR42	2007-000090	R-CHIP:10Kohm,5%,1/16W,DA,TP,1608	
SC2	2203-001573	C-CERAMIC,CHIP:12pF,5%,50V,CH,1608,1.6mm		SR44	2007-000078	R-CHIP:1Kohm,5%,1/16W,DA,TP,1608	
SC20	2203-000189	C-CERAMIC,CHIP:100nF,+80-20%,25V,Y5V,TP,		SR45	2007-000078	R-CHIP:1Kohm,5%,1/16W,DA,TP,1608	
SC21	2203-001567	C-CERAMIC,CHIP:10pF,0.5pF,50V,CH,TP,1608		SR46	2007-000078	R-CHIP:1Kohm,5%,1/16W,DA,TP,1608	
SC26	2203-002398	C-CERAMIC,CHIP:22nF,10%,50V,X7R,TP,1608,		SR47	2007-000078	R-CHIP:1Kohm,5%,1/16W,DA,TP,1608	
SC29	2203-000372	C-CERAMIC,CHIP:15nF,10%,50V,X7R,TP,1608,		SR48	2007-000109	R-CHIP:1Mohm,5%,1/16W,DA,TP,1608	
SC3	2203-001573	C-CERAMIC,CHIP:12pF,5%,50V,CH,1608,1.6mm		SR49	2007-000109	R-CHIP:1Mohm,5%,1/16W,DA,TP,1608	
SC30	2203-000372	C-CERAMIC,CHIP:15nF,10%,50V,X7R,TP,1608,		SR5	2007-000087	R-CHIP:6.8Kohm,5%,1/16W,DA,TP,1608	
SC31	2203-000491	C-CERAMIC,CHIP:2.2nF,10%,50V,X7R,TP,1608		SR50	2007-000082	R-CHIP:3.3Kohm,5%,1/16W,DA,TP,1608	
SC32	2203-000491	C-CERAMIC,CHIP:2.2nF,10%,50V,X7R,TP,1608		SR51	2007-000082	R-CHIP:3.3Kohm,5%,1/16W,DA,TP,1608	
SC33	2203-000560	C-CERAMIC,CHIP:220nF,+80-20%,25V,Y5V,TP,		SR52	2007-000704	R-CHIP:3.6Kohm,5%,1/16W,DA,TP,1608	
SC34	2203-000405	C-CERAMIC,CHIP:180pF,5%,50V,NPO,TP,1608,		SR53	2007-000123	R-CHIP:1.5Kohm,5%,1/16W,DA,TP,1608	
SC36	2203-000189	C-CERAMIC,CHIP:100nF,+80-20%,25V,Y5V,TP,		SR54	2007-000077	R-CHIP:470ohm,5%,1/16W,DA,TP,1608	
SC37	2203-000189	C-CERAMIC,CHIP:100nF,+80-20%,25V,Y5V,TP,		SR6	2007-000098	R-CHIP:56Kohm,5%,1/16W,DA,TP,1608	
SC38	2203-000189	C-CERAMIC,CHIP:100nF,+80-20%,25V,Y5V,TP,		SR7	2007-000799	R-CHIP:360ohm,5%,1/16W,DA,TP,1608	
SC39	2203-000189	C-CERAMIC,CHIP:100nF,+80-20%,25V,Y5V,TP,		SR8	2007-000070	R-CHIP:0ohm,5%,1/16W,DA,TP,1608	
SC4	2203-000189	C-CERAMIC,CHIP:100nF,+80-20%,25V,Y5V,TP,		SR9	2007-000084	R-CHIP:4.7Kohm,5%,1/16W,DA,TP,1608	
SC5	2203-000189	C-CERAMIC,CHIP:100nF,+80-20%,25V,Y5V,TP,		SY1	2801-000261	CRYSTAL-UNIT:33.8688MHZ,50PPM,28-AAA,12P	
SC6	2203-000189	C-CERAMIC,CHIP:100nF,+80-20%,25V,Y5V,TP,		VC1	2203-000189	C-CERAMIC,CHIP:100nF,+80-20%,25V,Y5V,TP,	
SC7	2203-000189	C-CERAMIC,CHIP:100nF,+80-20%,25V,Y5V,TP,		VC10	2203-000189	C-CERAMIC,CHIP:100nF,+80-20%,25V,Y5V,TP,	
SC9	2203-000560	C-CERAMIC,CHIP:220nF,+80-20%,25V,Y5V,TP,		VC11	2203-000189	C-CERAMIC,CHIP:100nF,+80-20%,25V,Y5V,TP,	
SD2	0407-000114	DIODE-ARRAY:DAN202K,80V,100mA,CA2-3,SOT-		VC12	2203-000189	C-CERAMIC,CHIP:100nF,+80-20%,25V,Y5V,TP,	
SD3	0407-000114	DIODE-ARRAY:DAN202K,80V,100mA,CA2-3,SOT-		VC13	2203-000189	C-CERAMIC,CHIP:100nF,+80-20%,25V,Y5V,TP,	
SE1	2401-002144	C-AL:47uF,20%,16V,GP,TP,5x11,5		VC14	2203-000189	C-CERAMIC,CHIP:100nF,+80-20%,25V,Y5V,TP,	
SE2	2401-002144	C-AL:47uF,20%,16V,GP,TP,5x11,5		VC15	2203-000189	C-CERAMIC,CHIP:100nF,+80-20%,25V,Y5V,TP,	
SE3	2401-002144	C-AL:47uF,20%,16V,GP,TP,5x11,5		VC16	2203-000189	C-CERAMIC,CHIP:100nF,+80-20%,25V,Y5V,TP,	
SE4	2401-000240	C-AL:100uF,20%,10V,GP,TP,5x11,5		VC17	2203-000189	C-CERAMIC,CHIP:100nF,+80-20%,25V,Y5V,TP,	
SE5	2401-000913	C-AL:22uF,20%,16V,GP,TP,5x11mm,2.5m		VC18	2203-000189	C-CERAMIC,CHIP:100nF,+80-20%,25V,Y5V,TP,	
SIC1	AH13-10030N	IC-ASIC:-,KS1452,QFP,80P,DSSP IC		VC19	2203-000189	C-CERAMIC,CHIP:100nF,+80-20%,25V,Y5V,TP,	
SIC2	0801-002097	IC-CMOS LOGIC:7SET08,AND GATE,SOP,5P,110		VC20	2203-000189	C-CERAMIC,CHIP:100nF,+80-20%,25V,Y5V,TP,	
SIC3	0801-002097	IC-CMOS LOGIC:7SET08,AND GATE,SOP,5P,110		VC21	2203-000189	C-CERAMIC,CHIP:100nF,+80-20%,25V,Y5V,TP,	
SIC8	1202-000121	IC-VOLTAGE COMP:2903,SOP,8P,150MIL,DUAL		VC22	2203-000189	C-CERAMIC,CHIP:100nF,+80-20%,25V,Y5V,TP,	
SL2	3301-000353	CORE-FERRITE BEAD:AB,2.0x1.25x0.9mm,-,-		VC23	2203-000189	C-CERAMIC,CHIP:100nF,+80-20%,25V,Y5V,TP,	
SL3	3301-000353	CORE-FERRITE BEAD:AB,2.0x1.25x0.9mm,-,-		VC24	2203-000189	C-CERAMIC,CHIP:100nF,+80-20%,25V,Y5V,TP,	
SL4	3301-000353	CORE-FERRITE BEAD:AB,2.0x1.25x0.9mm,-,-		VC25	2203-000189	C-CERAMIC,CHIP:100nF,+80-20%,25V,Y5V,TP,	
SQ1	0504-000128	TR-DIGITAL:-,NPN,200MW,22K/22K,SOT-23,TP		VC26	2203-000189	C-CERAMIC,CHIP:100nF,+80-20%,25V,Y5V,TP,	
SR1	2007-000090	R-CHIP:10Kohm,5%,1/16W,DA,TP,1608		VC27	2203-000189	C-CERAMIC,CHIP:100nF,+80-20%,25V,Y5V,TP,	

Electrical Parts List

Loc.No	Part No	Description ; Specification	Remark	Loc.No	Part No	Description ; Specification	Remark
VC28	2203-000189	C-CERAMIC,CHIP:100nF,+80-20%,25V,Y5V,TP,		VL14	3301-000353	CORE-FERRITE BEAD;AB,2.0x1.25x0.9mm,-,-	
VC29	2203-000189	C-CERAMIC,CHIP:100nF,+80-20%,25V,Y5V,TP,		VL15	3301-000353	CORE-FERRITE BEAD;AB,2.0x1.25x0.9mm,-,-	
VC3	2203-000189	C-CERAMIC,CHIP:100nF,+80-20%,25V,Y5V,TP,		VL16	3301-000353	CORE-FERRITE BEAD;AB,2.0x1.25x0.9mm,-,-	
VC30	2203-000189	C-CERAMIC,CHIP:100nF,+80-20%,25V,Y5V,TP,		VL17	3301-000353	CORE-FERRITE BEAD;AB,2.0x1.25x0.9mm,-,-	
VC31	2203-000189	C-CERAMIC,CHIP:100nF,+80-20%,25V,Y5V,TP,		VL18	3301-000353	CORE-FERRITE BEAD;AB,2.0x1.25x0.9mm,-,-	
VC32	2203-000189	C-CERAMIC,CHIP:100nF,+80-20%,25V,Y5V,TP,		VL19	3301-000353	CORE-FERRITE BEAD;AB,2.0x1.25x0.9mm,-,-	
VC33	2203-000189	C-CERAMIC,CHIP:100nF,+80-20%,25V,Y5V,TP,		VL2	3301-000353	CORE-FERRITE BEAD;AB,2.0x1.25x0.9mm,-,-	
VC34	2203-000189	C-CERAMIC,CHIP:100nF,+80-20%,25V,Y5V,TP,		VL20	3301-000353	CORE-FERRITE BEAD;AB,2.0x1.25x0.9mm,-,-	
VC35	2203-000189	C-CERAMIC,CHIP:100nF,+80-20%,25V,Y5V,TP,		VL21	3301-000353	CORE-FERRITE BEAD;AB,2.0x1.25x0.9mm,-,-	
VC36	2203-000560	C-CERAMIC,CHIP:220nF,+80-20%,25V,Y5V,TP,		VL22	3301-000353	CORE-FERRITE BEAD;AB,2.0x1.25x0.9mm,-,-	
VC37	2203-000560	C-CERAMIC,CHIP:220nF,+80-20%,25V,Y5V,TP,		VL23	3301-000353	CORE-FERRITE BEAD;AB,2.0x1.25x0.9mm,-,-	
VC38	2203-000560	C-CERAMIC,CHIP:220nF,+80-20%,25V,Y5V,TP,		VL24	3301-000353	CORE-FERRITE BEAD;AB,2.0x1.25x0.9mm,-,-	
VC39	2203-000560	C-CERAMIC,CHIP:220nF,+80-20%,25V,Y5V,TP,		VL25	3301-000353	CORE-FERRITE BEAD;AB,2.0x1.25x0.9mm,-,-	
VC4	2203-000189	C-CERAMIC,CHIP:100nF,+80-20%,25V,Y5V,TP,		VL26	3301-000353	CORE-FERRITE BEAD;AB,2.0x1.25x0.9mm,-,-	
VC40	2203-000560	C-CERAMIC,CHIP:220nF,+80-20%,25V,Y5V,TP,		VL27	3301-000353	CORE-FERRITE BEAD;AB,2.0x1.25x0.9mm,-,-	
VC41	2203-000560	C-CERAMIC,CHIP:220nF,+80-20%,25V,Y5V,TP,		VL28	3301-000353	CORE-FERRITE BEAD;AB,2.0x1.25x0.9mm,-,-	
VC42	2203-000189	C-CERAMIC,CHIP:100nF,+80-20%,25V,Y5V,TP,		VL29	3301-000353	CORE-FERRITE BEAD;AB,2.0x1.25x0.9mm,-,-	
VC43	2203-000189	C-CERAMIC,CHIP:100nF,+80-20%,25V,Y5V,TP,		VL3	3301-000353	CORE-FERRITE BEAD;AB,2.0x1.25x0.9mm,-,-	
VC44	2203-000189	C-CERAMIC,CHIP:100nF,+80-20%,25V,Y5V,TP,		VL4	3301-000353	CORE-FERRITE BEAD;AB,2.0x1.25x0.9mm,-,-	
VC45	2203-000189	C-CERAMIC,CHIP:100nF,+80-20%,25V,Y5V,TP,		VL5	3301-000353	CORE-FERRITE BEAD;AB,2.0x1.25x0.9mm,-,-	
VC47	2203-000626	C-CERAMIC,CHIP:22pF,5%,50V,NPO,TP,1608,-		VL6	3301-000353	CORE-FERRITE BEAD;AB,2.0x1.25x0.9mm,-,-	
VC48	2203-000681	C-CERAMIC,CHIP:27pF,5%,50V,NPO,1608,-,TP		VR1	2007-000078	R-CHIP;1Kohm,5%,1/16W,DA,TP,1608	
VC5	2203-000189	C-CERAMIC,CHIP:100nF,+80-20%,25V,Y5V,TP,		VR10	2007-000084	R-CHIP;4.7Kohm,5%,1/16W,DA,TP,1608	
VC50	2203-000560	C-CERAMIC,CHIP:220nF,+80-20%,25V,Y5V,TP,		VR100	2007-001134	R-CHIP;68ohm,5%,1/16W,DA,TP,1608	
VC51	2203-000560	C-CERAMIC,CHIP:220nF,+80-20%,25V,Y5V,TP,		VR101	2007-001134	R-CHIP;68ohm,5%,1/16W,DA,TP,1608	
VC52	2203-000560	C-CERAMIC,CHIP:220nF,+80-20%,25V,Y5V,TP,		VR102	2007-000113	R-CHIP;33ohm,5%,1/16W,DA,TP,1608	
VC53	2203-000560	C-CERAMIC,CHIP:220nF,+80-20%,25V,Y5V,TP,		VR103	2007-000113	R-CHIP;33ohm,5%,1/16W,DA,TP,1608	
VC54	2203-000560	C-CERAMIC,CHIP:220nF,+80-20%,25V,Y5V,TP,		VR104	2007-000113	R-CHIP;33ohm,5%,1/16W,DA,TP,1608	
VC55	2203-000560	C-CERAMIC,CHIP:220nF,+80-20%,25V,Y5V,TP,		VR2	2007-000084	R-CHIP;4.7Kohm,5%,1/16W,DA,TP,1608	
VC6	2203-000189	C-CERAMIC,CHIP:100nF,+80-20%,25V,Y5V,TP,		VR21	2007-000090	R-CHIP;10Kohm,5%,1/16W,DA,TP,1608	
VC61	2203-000815	C-CERAMIC,CHIP:33pF,5%,50V,NPO,TP,1608,-		VR22	2007-000090	R-CHIP;10Kohm,5%,1/16W,DA,TP,1608	
VC62	2203-000815	C-CERAMIC,CHIP:33pF,5%,50V,NPO,TP,1608,-		VR23	2007-000090	R-CHIP;10Kohm,5%,1/16W,DA,TP,1608	
VC65	2203-000815	C-CERAMIC,CHIP:33pF,5%,50V,NPO,TP,1608,-		VR24	2007-000090	R-CHIP;10Kohm,5%,1/16W,DA,TP,1608	
VC66	2203-000815	C-CERAMIC,CHIP:33pF,5%,50V,NPO,TP,1608,-		VR25	2007-000090	R-CHIP;10Kohm,5%,1/16W,DA,TP,1608	
VC67	2203-000815	C-CERAMIC,CHIP:33pF,5%,50V,NPO,TP,1608,-		VR26	2007-000090	R-CHIP;10Kohm,5%,1/16W,DA,TP,1608	
VC68	2203-000815	C-CERAMIC,CHIP:33pF,5%,50V,NPO,TP,1608,-		VR27	2007-000090	R-CHIP;10Kohm,5%,1/16W,DA,TP,1608	
VC69	2203-000626	C-CERAMIC,CHIP:22pF,5%,50V,NPO,TP,1608,-		VR28	2007-000090	R-CHIP;10Kohm,5%,1/16W,DA,TP,1608	
VC7	2203-000189	C-CERAMIC,CHIP:100nF,+80-20%,25V,Y5V,TP,		VR3	2007-000074	R-CHIP;100ohm,5%,1/16W,DA,TP,1608	
VC70	2203-000626	C-CERAMIC,CHIP:22pF,5%,50V,NPO,TP,1608,-		VR30	2007-000113	R-CHIP;33ohm,5%,1/16W,DA,TP,1608	
VC71	2203-000626	C-CERAMIC,CHIP:22pF,5%,50V,NPO,TP,1608,-		VR31	2007-000113	R-CHIP;33ohm,5%,1/16W,DA,TP,1608	
VC72	2203-000626	C-CERAMIC,CHIP:22pF,5%,50V,NPO,TP,1608,-		VR32	2007-000113	R-CHIP;33ohm,5%,1/16W,DA,TP,1608	
VC73	2203-000626	C-CERAMIC,CHIP:22pF,5%,50V,NPO,TP,1608,-		VR33	2007-000113	R-CHIP;33ohm,5%,1/16W,DA,TP,1608	
VC74	2203-000626	C-CERAMIC,CHIP:22pF,5%,50V,NPO,TP,1608,-		VR34	2007-000113	R-CHIP;33ohm,5%,1/16W,DA,TP,1608	
VC75	2203-000626	C-CERAMIC,CHIP:22pF,5%,50V,NPO,TP,1608,-		VR35	2007-000113	R-CHIP;33ohm,5%,1/16W,DA,TP,1608	
VC76	2203-000626	C-CERAMIC,CHIP:22pF,5%,50V,NPO,TP,1608,-		VR36	2007-000113	R-CHIP;33ohm,5%,1/16W,DA,TP,1608	
VC77	2203-000626	C-CERAMIC,CHIP:22pF,5%,50V,NPO,TP,1608,-		VR37	2007-000113	R-CHIP;33ohm,5%,1/16W,DA,TP,1608	
VC78	2203-000626	C-CERAMIC,CHIP:22pF,5%,50V,NPO,TP,1608,-		VR38	2007-000113	R-CHIP;33ohm,5%,1/16W,DA,TP,1608	
VC8	2203-000189	C-CERAMIC,CHIP:100nF,+80-20%,25V,Y5V,TP,		VR39	2007-000113	R-CHIP;33ohm,5%,1/16W,DA,TP,1608	
VC81	2203-000851	C-CERAMIC,CHIP:39pF,5%,50V,NPO,TP,1608,-		VR4	2007-000084	R-CHIP;4.7Kohm,5%,1/16W,DA,TP,1608	
VC82	2203-000851	C-CERAMIC,CHIP:39pF,5%,50V,NPO,TP,1608,-		VR40	2007-000113	R-CHIP;33ohm,5%,1/16W,DA,TP,1608	
VC83	2203-001071	C-CERAMIC,CHIP:56pF,5%,50V,NPO,TP,1608,-		VR41	2007-000113	R-CHIP;33ohm,5%,1/16W,DA,TP,1608	
VC84	2203-000236	C-CERAMIC,CHIP:100pF,5%,50V,NPO,TP,1608,		VR42	2007-000074	R-CHIP;100ohm,5%,1/16W,DA,TP,1608	
VC85	2203-000236	C-CERAMIC,CHIP:100pF,5%,50V,NPO,TP,1608,		VR43	2007-000074	R-CHIP;100ohm,5%,1/16W,DA,TP,1608	
VC9	2203-000189	C-CERAMIC,CHIP:100nF,+80-20%,25V,Y5V,TP,		VR44	2007-000074	R-CHIP;100ohm,5%,1/16W,DA,TP,1608	
VE1	2401-002165	C-AL;100uF,20%,16V,GP,TP,6.3x7,5		VR45	2007-000074	R-CHIP;100ohm,5%,1/16W,DA,TP,1608	
VE2	2401-002165	C-AL;100uF,20%,16V,GP,TP,6.3x7,5		VR46	2007-000074	R-CHIP;100ohm,5%,1/16W,DA,TP,1608	
VIC1	1204-001438	IC-DECODER;ZIVA-3,VQFP,208P,1098MIL,PLAS		VR47	2007-000074	R-CHIP;100ohm,5%,1/16W,DA,TP,1608	
VIC10	1105-001259	IC-DRAM;416S1020,16BIT,TSOP,50P,400MIL,8		VR48	2007-000074	R-CHIP;100ohm,5%,1/16W,DA,TP,1608	
VIC3	0801-002097	IC-CMOS LOGIC;7SET08,AND GATE,SOP,5P,110		VR49	2007-000074	R-CHIP;100ohm,5%,1/16W,DA,TP,1608	
VIC4	1105-001259	IC-DRAM;416S1020,16BIT,TSOP,50P,400MIL,8		VR50	2007-000074	R-CHIP;100ohm,5%,1/16W,DA,TP,1608	
VIC6	AH14-10004R	IC;M74HCU04,SOP,TAPE 14P		VR51	2007-000074	R-CHIP;100ohm,5%,1/16W,DA,TP,1608	
VL1	3301-000353	CORE-FERRITE BEAD;AB,2.0x1.25x0.9mm,-,-		VR52	2007-000074	R-CHIP;100ohm,5%,1/16W,DA,TP,1608	
VL10	2007-000029	R-CHIP;0OHM,5%,1/10W,DA,TP,2012		VR54	2007-000074	R-CHIP;100ohm,5%,1/16W,DA,TP,1608	
VL11	3301-000353	CORE-FERRITE BEAD;AB,2.0x1.25x0.9mm,-,-		VR55	2007-000074	R-CHIP;100ohm,5%,1/16W,DA,TP,1608	
VL12	3301-000353	CORE-FERRITE BEAD;AB,2.0x1.25x0.9mm,-,-		VR56	2007-000070	R-CHIP;0ohm,5%,1/16W,DA,TP,1608	
VL13	3301-000353	CORE-FERRITE BEAD;AB,2.0x1.25x0.9mm,-,-		VR57	2007-000070	R-CHIP;0ohm,5%,1/16W,DA,TP,1608	

Loc.No	Part No	Description ; Specification	Remark	Loc.No	Part No	Description ; Specification	Remark
VR58	2007-000075	R-CHIP:220ohm,5%,1/16W,DA,TP,1608		602		ASSY-PCB-JACK;DVD-739	
VR59	2007-000075	R-CHIP:220ohm,5%,1/16W,DA,TP,1608		AC1	2203-000192	C-CERAMIC,CHIP:100nF,+80-20%,50V,Y5V,TP,	
VR60	2007-000075	R-CHIP:220ohm,5%,1/16W,DA,TP,1608		AC10	2203-000444	C-CERAMIC,CHIP:1nF,10%,50V,X7R,TP,2012,-	
VR61	2007-000075	R-CHIP:220ohm,5%,1/16W,DA,TP,1608		AC11	2202-000806	C-CERAMIC,MLC-AXIAL:220pF,10%,50V,Y5P,TP	
VR62	2007-000075	R-CHIP:220ohm,5%,1/16W,DA,TP,1608		AC12	2203-000595	C-CERAMIC,CHIP:220pF,5%,50V,NPO,TP,2012,	
VR63	2007-000075	R-CHIP:220ohm,5%,1/16W,DA,TP,1608		AC2	2203-000192	C-CERAMIC,CHIP:100nF,+80-20%,50V,Y5V,TP,	
VR64	2007-000075	R-CHIP:220ohm,5%,1/16W,DA,TP,1608		AC3	2202-002037	C-CERAMIC,MLC-AXIAL:100nF,80-20%,50V,Y5V,TP,	
VR65	2007-000075	R-CHIP:220ohm,5%,1/16W,DA,TP,1608		AC4	2203-000444	C-CERAMIC,CHIP:1nF,10%,50V,X7R,TP,2012,-	
VR66	2007-000074	R-CHIP:100ohm,5%,1/16W,DA,TP,1608		AC5	2203-000595	C-CERAMIC,CHIP:220pF,5%,50V,NPO,TP,2012,	
VR67	2007-000074	R-CHIP:100ohm,5%,1/16W,DA,TP,1608		AC56	2203-000192	C-CERAMIC,CHIP:100nF,+80-20%,50V,Y5V,TP,	
VR68	2007-000074	R-CHIP:100ohm,5%,1/16W,DA,TP,1608		AC6	2203-000595	C-CERAMIC,CHIP:220pF,5%,50V,NPO,TP,2012,	
VR69	2007-000074	R-CHIP:100ohm,5%,1/16W,DA,TP,1608		AC60	2202-002037	C-CERAMIC,MLC-AXIAL:100nF,80-20%,50V,Y5V,TP,	
VR7	2007-000116	R-CHIP:120ohm,5%,1/16W,DA,TP,1608		AC7	2203-000192	C-CERAMIC,CHIP:100nF,+80-20%,50V,Y5V,TP,	
VR70	2007-000074	R-CHIP:100ohm,5%,1/16W,DA,TP,1608		AC71	2203-000192	C-CERAMIC,CHIP:100nF,+80-20%,50V,Y5V,TP,	
VR71	2007-000074	R-CHIP:100ohm,5%,1/16W,DA,TP,1608		AC73	2301-000161	C-FILM,PEF:12nF,5%,50V,6.5X5.5X3.0X5,5mm	
VR72	2007-000074	R-CHIP:100ohm,5%,1/16W,DA,TP,1608		AC74	2301-000161	C-FILM,PEF:12nF,5%,50V,6.5X5.5X3.0X5,5mm	
VR73	2007-000074	R-CHIP:100ohm,5%,1/16W,DA,TP,1608		AC8	2203-000192	C-CERAMIC,CHIP:100nF,+80-20%,50V,Y5V,TP,	
VR74	2007-000074	R-CHIP:100ohm,5%,1/16W,DA,TP,1608		AC90	2202-000849	C-CERAMIC,MLC-AXIAL:18pF,5%,50V,CH,TP,3.	
VR75	2007-000074	R-CHIP:100ohm,5%,1/16W,DA,TP,1608		AC94	2202-000849	C-CERAMIC,MLC-AXIAL:18pF,5%,50V,CH,TP,3.	
VR76	2007-000074	R-CHIP:100ohm,5%,1/16W,DA,TP,1608		AC95	2202-000849	C-CERAMIC,MLC-AXIAL:18pF,5%,50V,CH,TP,3.	
VR77	2007-000074	R-CHIP:100ohm,5%,1/16W,DA,TP,1608		AC98	2203-000239	C-CERAMIC,CHIP:100pF,5%,50V,NPO,TP,2012,	
VR78	2007-000074	R-CHIP:100ohm,5%,1/16W,DA,TP,1608		AD1	0407-000114	DIODE-ARRAY:DAN202K,80V,100mA,CA2-3,SOT-	
VR79	2007-000074	R-CHIP:100ohm,5%,1/16W,DA,TP,1608		AD2	0407-000114	DIODE-ARRAY:DAN202K,80V,100mA,CA2-3,SOT-	
VR80	2007-000074	R-CHIP:100ohm,5%,1/16W,DA,TP,1608		AD4	0401-000101	DIODE-SWITCHING:1N4148,100V,200mA,DO-35,	
VR81	2007-000074	R-CHIP:100ohm,5%,1/16W,DA,TP,1608		AD5	0401-000101	DIODE-SWITCHING:1N4148,100V,200mA,DO-35,	
VR82	2007-000402	R-CHIP:150ohm,5%,1/16W,DA,TP,1608		AD6	0407-000114	DIODE-ARRAY:DAN202K,80V,100mA,CA2-3,SOT-	
VR83	2007-001134	R-CHIP:68ohm,5%,1/16W,DA,TP,1608		AD7	0407-000114	DIODE-ARRAY:DAN202K,80V,100mA,CA2-3,SOT-	
VR84	2007-001134	R-CHIP:68ohm,5%,1/16W,DA,TP,1608		AE1	2401-002042	C-AL:220uF,20%,10V,GP,TP,6.3x11,5	
VR85	2007-001134	R-CHIP:68ohm,5%,1/16W,DA,TP,1608		AE10	2401-002144	C-AL:47uF,20%,16V,GP,TP,5x11,5	
VR86	2007-001134	R-CHIP:68ohm,5%,1/16W,DA,TP,1608		AE11	2401-002144	C-AL:47uF,20%,16V,GP,TP,5x11,5	
VR87	2007-001134	R-CHIP:68ohm,5%,1/16W,DA,TP,1608		AE2	2401-002042	C-AL:220uF,20%,10V,GP,TP,6.3x11,5	
VR88	2007-001134	R-CHIP:68ohm,5%,1/16W,DA,TP,1608		AE3	2401-002042	C-AL:220uF,20%,10V,GP,TP,6.3x11,5	
VR89	2007-001134	R-CHIP:68ohm,5%,1/16W,DA,TP,1608		AE30	2401-000302	C-AL:100uF,20%,25V,GP,TP,6.3x11,5	
VR9	2007-000109	R-CHIP:1Mohm,5%,1/16W,DA,TP,1608		AE31	2401-001969	C-AL:470uF,20%,25V,GP,TP,10x12.5,5	
VR90	2007-001134	R-CHIP:68ohm,5%,1/16W,DA,TP,1608		AE4	2401-002068	C-AL:33uF,20%,16V,GP,TP,5x11,5	
VR91	2007-001134	R-CHIP:68ohm,5%,1/16W,DA,TP,1608		AE5	2401-002068	C-AL:33uF,20%,16V,GP,TP,5x11,5	
VR92	2007-001134	R-CHIP:68ohm,5%,1/16W,DA,TP,1608		AE6	2401-000913	C-AL:22uF,20%,16V,GP,TP,5x11mm,2.5m	
VR93	2007-001134	R-CHIP:68ohm,5%,1/16W,DA,TP,1608		AE7	2401-002068	C-AL:33uF,20%,16V,GP,TP,5x11,5	
VR94	2007-001134	R-CHIP:68ohm,5%,1/16W,DA,TP,1608		AE8	2401-002068	C-AL:33uF,20%,16V,GP,TP,5x11,5	
VR95	2007-001134	R-CHIP:68ohm,5%,1/16W,DA,TP,1608		AE9	2401-000913	C-AL:22uF,20%,16V,GP,TP,5x11mm,2.5m	
VR96	2007-001134	R-CHIP:68ohm,5%,1/16W,DA,TP,1608		AIC1	1002-001129	IC-D/A CONVERTER:AK4324VF,24BIT,V5SOP,24P	
VR97	2007-001134	R-CHIP:68ohm,5%,1/16W,DA,TP,1608		AIC5	AH14-10004R	IC:M74HCU04,SOP,TAPE 14P	
VR98	2007-001134	R-CHIP:68ohm,5%,1/16W,DA,TP,1608		AL1	3301-000353	CORE-FERRITE BEAD:AB,2.0x1.25x0.9mm,-,-	
VR99	2007-000070	R-CHIP:0ohm,5%,1/16W,DA,TP,1608		AL19	2901-001125	FILTER-EMI ON BOARD:50V,0.5A,-,220pF,7x7	
VY1	2801-003554	CRYSTAL-UNIT:27MHz,10ppm,28-AAM,12pF,40o		AL2	3301-000353	CORE-FERRITE BEAD:AB,2.0x1.25x0.9mm,-,-	
				AL5	3301-000353	CORE-FERRITE BEAD:AB,2.0x1.25x0.9mm,-,-	
				AL6	3301-000353	CORE-FERRITE BEAD:AB,2.0x1.25x0.9mm,-,-	
				AOP1	1201-000163	IC-OP AMP:4560,SOP,8P,150MIL,DUAL,100V/M	
				AQ1	0501-000341	TR-SMALL SIGNAL:KSC1623-L,NPN,200mW,SOT-	
				AQ17	0504-000118	TR-DIGITAL:KSR1003,NPN,300MW,22K/22K,TO-	
				AQ18	0504-000118	TR-DIGITAL:KSR1003,NPN,300MW,22K/22K,TO-	
				AQ19	0504-001003	TR-DIGITAL:KSR2003,PNP,300MW,22K/22K,TO-	
				AQ2	0501-000341	TR-SMALL SIGNAL:KSC1623-L,NPN,200mW,SOT-	
				AQ20	0504-000156	TR-DIGITAL:DTA124EKA,PNP,200mW,22K-22K	
				AQ21	0504-000128	TR-DIGITAL:-,NPN,200MW,22K/22K,SOT-23,TP	
				AQ22	0504-000156	TR-DIGITAL:DTA124EKA,PNP,200mW,22K-22K	
				AQ3	0501-000341	TR-SMALL SIGNAL:KSC1623-L,NPN,200mW,SOT-	
				AQ33	0504-000128	TR-DIGITAL:-,NPN,200MW,22K/22K,SOT-23,TP	
				AQ4	0501-000341	TR-SMALL SIGNAL:KSC1623-L,NPN,200mW,SOT-	
				AR1	2007-000290	R-CHIP:100OHM,5%,1/10W,DA,TP,2012	
				AR10	2001-000878	R-CARBON:6.2KOHM,5%,1/8W,AA,TP,1.8X3.2MM	
				AR11	2001-000878	R-CARBON:6.2KOHM,5%,1/8W,AA,TP,1.8X3.2MM	
				AR119	2007-000766	R-CHIP:330OHM,5%,1/10W,DA,TP,2012	
				AR12	2007-001055	R-CHIP:6.2KOHM,5%,1/10W,DA,TP,2012	
				AR121	2007-001247	R-CHIP:910HM,5%,1/10W,DA,TP,2012	

Electrical Parts List

Loc.No	Part No	Description ; Specification	Remark	Loc.No	Part No	Description ; Specification	Remark
AR13	2007-001055	R-CHIP:6.2KOHM,5%,1/10W,DA,TP,2012		FR101	2001-000273	R-CARBON:100KOHM,5%,1/8W,AA,TP,1.8X3.2MM	
AR130	2001-000281	R-CARBON:100OHM,5%,1/8W,AA,TP,1.8X3.2MM		FR102	2001-000273	R-CARBON:100KOHM,5%,1/8W,AA,TP,1.8X3.2MM	
AR134	2001-000281	R-CARBON:100OHM,5%,1/8W,AA,TP,1.8X3.2MM		FR103	2001-000273	R-CARBON:100KOHM,5%,1/8W,AA,TP,1.8X3.2MM	
AR138	2007-000029	R-CHIP:00HM,5%,1/10W,DA,TP,2012		FR104	2001-000273	R-CARBON:100KOHM,5%,1/8W,AA,TP,1.8X3.2MM	
AR14	2007-001055	R-CHIP:6.2KOHM,5%,1/10W,DA,TP,2012		FR105	2001-000273	R-CARBON:100KOHM,5%,1/8W,AA,TP,1.8X3.2MM	
AR15	2001-000290	R-CARBON:10KOHM,5%,1/8W,AA,TP,1.8X3.2MM		FR106	2001-000273	R-CARBON:100KOHM,5%,1/8W,AA,TP,1.8X3.2MM	
AR150	2001-000429	R-CARBON:1KOHM,5%,1/8W,AA,TP,1.8X3.2MM		FR11	2001-000281	R-CARBON:100OHM,5%,1/8W,AA,TP,1.8X3.2MM	
AR151	2001-000429	R-CARBON:1KOHM,5%,1/8W,AA,TP,1.8X3.2MM		FR12	2001-000281	R-CARBON:100OHM,5%,1/8W,AA,TP,1.8X3.2MM	
AR18	2001-000429	R-CARBON:1KOHM,5%,1/8W,AA,TP,1.8X3.2MM		FR13	2001-000281	R-CARBON:100OHM,5%,1/8W,AA,TP,1.8X3.2MM	
AR19	2001-000429	R-CARBON:1KOHM,5%,1/8W,AA,TP,1.8X3.2MM		FR16	2001-000027	R-CARBON:100OHM,5%,1/4W,AA,TP,2.4X6.4MM	
AR20	2001-000003	R-CARBON:330OHM,5%,1/8W,AA,TP,1.8X3.2MM		FR17	2001-000027	R-CARBON:100OHM,5%,1/4W,AA,TP,2.4X6.4MM	
AR21	2001-000878	R-CARBON:6.2KOHM,5%,1/8W,AA,TP,1.8X3.2MM		FR18	2001-000449	R-CARBON:2.2KOHM,5%,1/8W,AA,TP,1.8X3.2MM	
AR22	2001-000878	R-CARBON:6.2KOHM,5%,1/8W,AA,TP,1.8X3.2MM		FR19	2001-000449	R-CARBON:2.2KOHM,5%,1/8W,AA,TP,1.8X3.2MM	
AR23	2001-000878	R-CARBON:6.2KOHM,5%,1/8W,AA,TP,1.8X3.2MM		FR20	2001-000449	R-CARBON:2.2KOHM,5%,1/8W,AA,TP,1.8X3.2MM	
AR24	2007-001055	R-CHIP:6.2KOHM,5%,1/10W,DA,TP,2012		FR21	2001-000435	R-CARBON:1MOHM,5%,1/8W,AA,TP,1.8X3.2MM	
AR25	2007-001055	R-CHIP:6.2KOHM,5%,1/10W,DA,TP,2012		FR24	2001-000281	R-CARBON:100OHM,5%,1/8W,AA,TP,1.8X3.2MM	
AR26	2007-001055	R-CHIP:6.2KOHM,5%,1/10W,DA,TP,2012		FR25	2001-000780	R-CARBON:470OHM,5%,1/10W,DA,TP,2012	
AR27	2007-000300	R-CHIP:10KOHM,5%,1/10W,DA,TP,2012		FR26	2001-000281	R-CARBON:100OHM,5%,1/8W,AA,TP,1.8X3.2MM	
AR28	2001-000003	R-CARBON:330OHM,5%,1/8W,AA,TP,1.8X3.2MM		FR31	2007-000282	R-CHIP:100KOHM,5%,1/10W,DA,TP,2012	
AR29	2001-000281	R-CARBON:100OHM,5%,1/8W,AA,TP,1.8X3.2MM		FR32	2007-000282	R-CHIP:100KOHM,5%,1/10W,DA,TP,2012	
AR30	2001-000429	R-CARBON:1KOHM,5%,1/8W,AA,TP,1.8X3.2MM		FR33	2007-000282	R-CHIP:100KOHM,5%,1/10W,DA,TP,2012	
AR31	2001-000429	R-CARBON:1KOHM,5%,1/8W,AA,TP,1.8X3.2MM		FR34	2007-000282	R-CHIP:100KOHM,5%,1/10W,DA,TP,2012	
AR32	2007-000766	R-CHIP:330OHM,5%,1/10W,DA,TP,2012		FR35	2007-000282	R-CHIP:100KOHM,5%,1/10W,DA,TP,2012	
AR41	2001-000003	R-CARBON:330OHM,5%,1/8W,AA,TP,1.8X3.2MM		FR36	2007-000282	R-CHIP:100KOHM,5%,1/10W,DA,TP,2012	
AR42	2001-000281	R-CARBON:100OHM,5%,1/8W,AA,TP,1.8X3.2MM		FR37	2007-000282	R-CHIP:100KOHM,5%,1/10W,DA,TP,2012	
AR8	2007-000308	R-CHIP:10OHM,5%,1/10W,DA,TP,2012		FR43	2001-000793	R-CARBON:47OHM,5%,1/8W,AA,TP,1.8X3.2MM	
AR9	2001-000878	R-CARBON:6.2KOHM,5%,1/8W,AA,TP,1.8X3.2MM		FR44	2001-000429	R-CARBON:1KOHM,5%,1/8W,AA,TP,1.8X3.2MM	
AR90	2001-000241	R-CARBON:1.5KOHM,5%,1/8W,AA,TP,1.8X3.2MM		FR45	2001-000429	R-CARBON:1KOHM,5%,1/8W,AA,TP,1.8X3.2MM	
AR91	2001-000281	R-CARBON:100OHM,5%,1/8W,AA,TP,1.8X3.2MM		FR46	2001-000273	R-CARBON:100KOHM,5%,1/8W,AA,TP,1.8X3.2MM	
AR92	2001-000281	R-CARBON:100OHM,5%,1/8W,AA,TP,1.8X3.2MM		FR5	2001-000325	R-CARBON:120OHM,5%,1/8W,AA,TP,1.8X3.2MM	
AVJ1	3722-001355	JACK-RCA:3P(4P),3.2MM,NI,GRN/RED/BLU,-		FR57	2001-000290	R-CARBON:10KOHM,5%,1/8W,AA,TP,1.8X3.2MM	
AVJ2	3722-001358	JACK-RCA:3P,3.2MM,NI,BLK,-		FR58	2007-000029	R-CHIP:00HM,5%,1/10W,DA,TP,2012	
AVJ4	3722-001053	JACK-RCA:1P,3.2mm,NI,BLK,-		FR59	2007-000029	R-CHIP:00HM,5%,1/10W,DA,TP,2012	
AZD1	0403-000551	DIODE-ZENER:MTZ3.9B,3.9V,3.89-4.16V,500m		FY1	2802-000108	RESONATOR-CERAMIC:12MHZ,0.5%,BK,10.0X5.0	
CN11	3708-000277	CONNECTOR-FPC/FC/PIC:35P,1.25mm,ANGLE,SN		PC01	2305-001021	C-FILM,MPEF:100nF,20%,275V,TP,17.5x7x13	△
CN12	AH39-00035A	LEAD CONNECTOR-ASSY:-,5264-08,35023-08,8		PC02	2305-001021	C-FILM,MPEF:100nF,20%,275V,TP,17.5x7x13	△
CN16	3711-001061	CONNECTOR-HEADER-BOX,6P,1R,2mm,ANGLE,SN		PC04	2301-000140	C-FILM,PEF:10nF,10%,630V,BK,16.5X9.5X5.7	
CN18	3711-000967	CONNECTOR-HEADER-BOX,4P,1R,2mm,ANGLE,SN		PC05	2201-000129	C-CERAMIC,DISC:100pF,10%,1KV,Y5P,TP,6x5	△
FC1	2202-002037	C-CERAMIC,MLC-AXIAL:100nF,80-20%,50V,Y5V		PC07	2301-000129	C-FILM,PEF:100nF,5%,50V,TP,10X9X4.3X5,5m	
FC10	2202-002037	C-CERAMIC,MLC-AXIAL:100nF,80-20%,50V,Y5V		PC09	2301-000415	C-FILM,PEF:22nF,5%,50V,TP,6.5x10.5x4mm,5	
FC14	2202-002037	C-CERAMIC,MLC-AXIAL:100nF,80-20%,50V,Y5V		PC10	2201-000916	C-CERAMIC,DISC:100pF,10%,400V,Y5U,TP,10x	△
FC15	2202-002037	C-CERAMIC,MLC-AXIAL:100nF,80-20%,50V,Y5V		PC11	2201-000916	C-CERAMIC,DISC:100pF,10%,400V,Y5U,TP,10x	△
FC16	2202-000173	C-CERAMIC,MLC-AXIAL:1nF,10%,50V,Y5P,TP,1		PC12	2203-000575	C-CERAMIC,CHIP:220NF,10%,25V,X7R,TP,2012	
FC2	2203-000389	C-CERAMIC,CHIP:15pF,5%,50V,NPO,TP,2012,-		PC13	2203-000575	C-CERAMIC,CHIP:220NF,10%,25V,X7R,TP,2012	
FC3	2203-000389	C-CERAMIC,CHIP:15pF,5%,50V,NPO,TP,2012,-		PC14	2203-000575	C-CERAMIC,CHIP:220NF,10%,25V,X7R,TP,2012	
FC4	2202-002037	C-CERAMIC,MLC-AXIAL:100nF,80-20%,50V,Y5V		PC15	2203-000575	C-CERAMIC,CHIP:220NF,10%,25V,X7R,TP,2012	
FC6	2202-002037	C-CERAMIC,MLC-AXIAL:100nF,80-20%,50V,Y5V		PC44	2301-000129	C-FILM,PEF:100nF,5%,50V,TP,10X9X4.3X5,5m	
FD10	0401-000101	DIODE-SWITCHING:1N4148,100V,200mA,DO-35,		PCN01	3711-000178	CONNECTOR-HEADER:1WALL,2P,1R,3.96mm,STRA	△
FD6	0401-000101	DIODE-SWITCHING:1N4148,100V,200mA,DO-35,		PD01	0402-001009	DIODE-RECTIFIER:1SR139,600V,1A,MSR,TP	△
FD7	0401-000101	DIODE-SWITCHING:1N4148,100V,200mA,DO-35,		PD02	0402-001009	DIODE-RECTIFIER:1SR139,600V,1A,MSR,TP	△
FD8	0401-000101	DIODE-SWITCHING:1N4148,100V,200mA,DO-35,		PD03	0402-001009	DIODE-RECTIFIER:1SR139,600V,1A,MSR,TP	△
FD9	0403-000551	DIODE-ZENER:MTZ3.9B,3.9V,3.89-4.16V,500m		PD04	0402-001009	DIODE-RECTIFIER:1SR139,600V,1A,MSR,TP	△
FE1	2401-000913	C-AL:22uF,20%,16V,GP,TP,5x11mm,2.5m		PD11	0402-000378	DIODE-RECTIFIER:EG01C,1000V,500mA,DO-41	
FE12	2401-000240	C-AL:100uF,20%,10V,GP,TP,5x11,5		PD12	0402-001013	DIODE-RECTIFIER:1SR153-400,400V,800mA,DO	
FE13	2401-000240	C-AL:100uF,20%,10V,GP,TP,5x11,5		PD3	0402-001013	DIODE-RECTIFIER:1SR153-400,400V,800mA,DO	
FE2	2401-002144	C-AL:47uF,20%,16V,GP,TP,5x11,5		PD31	0402-001013	DIODE-RECTIFIER:1SR153-400,400V,800mA,DO	
FE5	2401-002144	C-AL:47uF,20%,16V,GP,TP,5x11,5		PD32	0402-000430	DIODE-RECTIFIER:FML-G02S,200V,3.0A,TO-22	
FE8	2401-002144	C-AL:47uF,20%,16V,GP,TP,5x11,5		PD33	0402-001251	DIODE-RECTIFIER:FVG-22R,200V,10A,TO-220F	
FIC1	AH09-00010A	IC-MICOM MASKING:LC866232,100PIN,QIP,FLT		PD34	0402-001251	DIODE-RECTIFIER:FVG-22R,200V,10A,TO-220F	
FIC2	1203-001252	IC-VOL. DETECTOR:7545,TO-92,3P,-,PLASTIC		PD35	0402-001013	DIODE-RECTIFIER:1SR153-400,400V,800mA,DO	
FIC3	0801-002166	IC-CMOS LOGIC:7SHU04,INVERTER,SSOP,5P,63		PD37	0402-000132	DIODE-RECTIFIER:1N4004,400V,1A,DO-41,TP	
FIC4	AH59-60010A	MODULE-REMOCON:-,GP1U281Q,38KHz,940,MESH		PD38	0402-000132	DIODE-RECTIFIER:1N4004,400V,1A,DO-41,TP	
FL1	2701-000114	INDUCTOR-AXIAL:10uH,10%,2.5x3.4mm		PE10	2401-001353	C-AL:470uF,20%,10V,GP,TP,8x11.5,5	
FL2	2701-000113	INDUCTOR-AXIAL:100uH,5%,2.5x3.4mm		PE11	2401-000302	C-AL:100uF,20%,25V,GP,TP,6.3x11,5	
FR1	2001-000273	R-CARBON:100KOHM,5%,1/8W,AA,TP,1.8X3.2MM		PE12	2401-000302	C-AL:100uF,20%,25V,GP,TP,6.3x11,5	
FR10	2001-000281	R-CARBON:100OHM,5%,1/8W,AA,TP,1.8X3.2MM		PE13	2401-000302	C-AL:100uF,20%,25V,GP,TP,6.3x11,5	

Loc.No	Part No	Description ; Specification	Remark	Loc.No	Part No	Description ; Specification	Remark
PE3	2401-001682	C-AL:82uF,20%,400V,GP,BK,22x25,10mm	△	VC1	2203-000192	C-CERAMIC,CHIP:100nF,+80-20%,50V,Y5V,TP,	
PE31	2401-000302	C-AL:100uF,20%,25V,GP,TP,6.3x11,5		VC10	2202-000849	C-CERAMIC,MLC-AXIAL:18pf,5%,50V,CH,TP,3.	
PE32	2401-001998	C-AL:1000uF,20%,25V,GP,TP,10x20,5mm		VC100	2203-000192	C-CERAMIC,CHIP:100nF,+80-20%,50V,Y5V,TP,	
PE33	2401-001998	C-AL:1000uF,20%,25V,GP,TP,10x20,5mm		VC101	2203-000192	C-CERAMIC,CHIP:100nF,+80-20%,50V,Y5V,TP,	
PE35	2401-000360	C-AL:100uF,20%,50V,GP,TP,8x11,5,5		VC102	2202-002037	C-CERAMIC,MLC-AXIAL:100nF,80-20%,50V,Y5V	
PE36	2401-001998	C-AL:1000uF,20%,25V,GP,TP,10x20,5mm		VC103	2202-002037	C-CERAMIC,MLC-AXIAL:100nF,80-20%,50V,Y5V	
PE37	2401-001134	C-AL:330uF,20%,35V,WT,TP,10x16,5		VC104	2202-002037	C-CERAMIC,MLC-AXIAL:100nF,80-20%,50V,Y5V	
PE38	2401-002144	C-AL:47uF,20%,16V,GP,TP,5x11,5		VC105	2007-000029	R-CHIP:00HM,5%,1/10W,DA,TP,2012	
PE39	2401-001134	C-AL:330uF,20%,35V,WT,TP,10x16,5		VC11	2202-000849	C-CERAMIC,MLC-AXIAL:18pf,5%,50V,CH,TP,3.	
PE4	2401-000302	C-AL:100uF,20%,25V,GP,TP,6.3x11,5		VC12	2202-000849	C-CERAMIC,MLC-AXIAL:18pf,5%,50V,CH,TP,3.	
PE41	2401-002036	C-AL:1uF,20%,50V,GP,TP,5x11,2.5mm		VC13	2202-000849	C-CERAMIC,MLC-AXIAL:18pf,5%,50V,CH,TP,3.	
PE42	2401-002144	C-AL:47uF,20%,16V,GP,TP,5x11,5		VC14	2202-000849	C-CERAMIC,MLC-AXIAL:18pf,5%,50V,CH,TP,3.	
PE43	2401-002144	C-AL:47uF,20%,16V,GP,TP,5x11,5		VC2	2203-000192	C-CERAMIC,CHIP:100nF,+80-20%,50V,Y5V,TP,	
PE44	2401-002036	C-AL:1uF,20%,50V,GP,TP,5x11,2.5mm		VC3	2203-000192	C-CERAMIC,CHIP:100nF,+80-20%,50V,Y5V,TP,	
PE6	2401-001583	C-AL:47uF,20%,50V,WT,TP,6.3x11,5		VC4	2202-000849	C-CERAMIC,MLC-AXIAL:18pf,5%,50V,CH,TP,3.	
PFOA	3601-000453	FUSE-FERRULE:250V,1.6A,SB,GLASS,5.2x20mm	△	VC5	2202-000849	C-CERAMIC,MLC-AXIAL:18pf,5%,50V,CH,TP,3.	
PIC1	1203-001721	IC-PWM CONTROLLER,STR-G6153T,TO-220,5P,1	△	VC6	2202-000849	C-CERAMIC,MLC-AXIAL:18pf,5%,50V,CH,TP,3.	
PIC2	0604-000186	PHOTO-COUPLER:TR,-,200mW,DIP-4,ST	△	VC7	2202-000849	C-CERAMIC,MLC-AXIAL:18pf,5%,50V,CH,TP,3.	
PIC3	AC14-12006D	IC-KA431Z,TO-92,TAPING		VC8	2202-000849	C-CERAMIC,MLC-AXIAL:18pf,5%,50V,CH,TP,3.	
PIC4	1203-000122	IC-NEGA.FIXED REG.:7908,TO-220,3P,-,PLAS		VC9	2202-000849	C-CERAMIC,MLC-AXIAL:18pf,5%,50V,CH,TP,3.	
PIC5	1203-001697	IC-VOLTAGE REGULATOR:78R08,TO-220,4P,-,P		VE51	2401-002042	C-AL:220uF,20%,10V,GP,TP,6.3x11,5	
PIC6	1203-001083	IC-VOLTAGE REGULATOR:3RF23,TO-202,4P,12.		VE54	2401-000369	C-AL:100uF,20%,6.3V,GP,-,6.3X11,5	
PL01	AC29-30050A	FILTER-LINE NOISE:-,400UH,-,250V,-	△	VE55	2401-000913	C-AL:22uF,20%,16V,GP,TP,5x11mm,2.5m	
PL02	AC27-92001Q	COIL-LINE FILTER:BSF-2120Z,25MH,-,-,-	△	VE58	2401-000369	C-AL:100uF,20%,6.3V,GP,-,6.3X11,5	
PL03	3301-000297	CORE-FERRITE BEAD:AA,3.6x1.2x5.7mm,1400,		VE58A	2401-000913	C-AL:22uF,20%,16V,GP,TP,5x11mm,2.5m	
PL11	3301-000297	CORE-FERRITE BEAD:AA,3.6x1.2x5.7mm,1400,		VE60	2401-001353	C-AL:470uF,20%,10V,GP,TP,8x11,5,5	
PQ1	0501-000398	TR-SMALL SIGNAL:KSC945,NPN,250mW,TO-92,T		VE61	2401-000913	C-AL:22uF,20%,16V,GP,TP,5x11mm,2.5m	
PQ2	0501-000616	TR-SMALL SIGNAL:KSC2328A-Y,NPN,1W,TO-92L		VE66	2401-001353	C-AL:470uF,20%,10V,GP,TP,8x11,5,5	
PQ21	0504-000142	TR-DIGITAL:KSR2001,PNP,300MW,4.7K/4.7K,T		VE67	2401-000913	C-AL:22uF,20%,16V,GP,TP,5x11mm,2.5m	
PQ22	0504-000118	TR-DIGITAL:KSR1003,NPN,300MW,22K/22K,TO-		VE69	2401-001353	C-AL:470uF,20%,10V,GP,TP,8x11,5,5	
PQ23	0502-000298	TR-POWER:KSD73,NPN,30W,TO-220,-,120-240		VE70	2401-002042	C-AL:220uF,20%,10V,GP,TP,6.3x11,5	
PQ24	0502-000298	TR-POWER:KSD73,NPN,30W,TO-220,-,120-240		VE71	2401-002042	C-AL:220uF,20%,10V,GP,TP,6.3x11,5	
PQ3	0504-000118	TR-DIGITAL:KSR1003,NPN,300MW,22K/22K,TO-		VE72	2401-002042	C-AL:220uF,20%,10V,GP,TP,6.3x11,5	
PQ4	0504-000142	TR-DIGITAL:KSR2001,PNP,300MW,4.7K/4.7K,T		VE73	2401-002042	C-AL:220uF,20%,10V,GP,TP,6.3x11,5	
PR10	2006-000262	R-CEMENT:2.7ohm,10%,2W,CB,ST,7.5x11x20.		VFD1	AH07-00002A	VF-DISPLAY:SVV-08M,21SEG,25X100MM,DVD-90	
PR11	2001-000073	R-CARBON:33KOHM,5%,1/4W,AA,TP,2.4X6.4MM		VIC50	1204-001366	IC-VIDEO ENCODER:SAA7128,QFP,44P,-,PLAST	
PR12	2001-000073	R-CARBON:33KOHM,5%,1/4W,AA,TP,2.4X6.4MM		VIC51	1201-001419	IC-VIDEO AMP:7660,SSOP,16P,173MIL,3,6DB,	
PR13	2001-000073	R-CARBON:33KOHM,5%,1/4W,AA,TP,2.4X6.4MM		VIC52	1201-001419	IC-VIDEO AMP:7660,SSOP,16P,173MIL,3,6DB,	
PR14	2001-000073	R-CARBON:33KOHM,5%,1/4W,AA,TP,2.4X6.4MM		VL100	3301-000353	CORE-FERRITE BEAD:AB,2.0x1.25x0.9mm,-,-	
PR15	2003-000994	R-METAL OXIDE(S):33Kohm,5%,2W,AF,TP,3.9x		VL110	3301-000297	CORE-FERRITE BEAD:AA,3.6x1.2x5.7mm,1400,	
PR16	2003-000994	R-METAL OXIDE(S):33Kohm,5%,2W,AF,TP,3.9x		VL111	3301-000297	CORE-FERRITE BEAD:AA,3.6x1.2x5.7mm,1400,	
PR17	2003-000148	R-METAL OXIDE:100OHM,5%,2W,AE,TP,6X16MM		VL112	3301-000353	CORE-FERRITE BEAD:AB,2.0x1.25x0.9mm,-,-	
PR18	2001-000666	R-CARBON:33OHM,5%,1/8W,AA,TP,1.8X3.2MM		VL113	2701-000138	INDUCTOR-AXIAL:18uH,5%,2.4x3.4mm	
PR2	2003-000148	R-METAL OXIDE:100OHM,5%,2W,AE,TP,6X16MM		VL115	2701-000002	INDUCTOR-AXIAL:100uH,10%,4.2x9.8mm	
PR20	2001-000429	R-CARBON:1KOHM,5%,1/8W,AA,TP,1.8X3.2MM		VL116	2701-000002	INDUCTOR-AXIAL:100uH,10%,4.2x9.8mm	
PR3	2001-000734	R-CARBON:4.7KOHM,5%,1/8W,AA,TP,1.8X3.2MM		VL119	3301-000353	CORE-FERRITE BEAD:AB,2.0x1.25x0.9mm,-,-	
PR31	2001-000034	R-CARBON:220OHM,5%,1/4W,AA,TP,2.4X6.4MM		VR10	2001-000008	R-CARBON:15KOHM,5%,1/8W,AA,TP,1.8X3.2MM	
PR32	2001-000429	R-CARBON:1KOHM,5%,1/8W,AA,TP,1.8X3.2MM		VR100	2001-000281	R-CARBON:100OHM,5%,1/8W,AA,TP,1.8X3.2MM	
PR33	2001-000429	R-CARBON:1KOHM,5%,1/8W,AA,TP,1.8X3.2MM		VR108	2001-000969	R-CARBON:75OHM,5%,1/8W,AA,TP,1.8X3.2MM	
PR34	2001-000440	R-CARBON:10HM,5%,1/8W,AA,TP,1.8X3.2MM		VR109	2001-000666	R-CARBON:33OHM,5%,1/8W,AA,TP,1.8X3.2MM	
PR35	2001-000362	R-CARBON:150OHM,5%,1/8W,AA,TP,1.8X3.2MM		VR11	2001-000008	R-CARBON:15KOHM,5%,1/8W,AA,TP,1.8X3.2MM	
PR36	2001-000221	R-CARBON:1.2KOHM,5%,1/8W,AA,TP,1.8X3.2MM		VR110	2001-000666	R-CARBON:33OHM,5%,1/8W,AA,TP,1.8X3.2MM	
PR37	2001-000429	R-CARBON:1KOHM,5%,1/8W,AA,TP,1.8X3.2MM		VR111	2001-000666	R-CARBON:33OHM,5%,1/8W,AA,TP,1.8X3.2MM	
PR38	2004-000869	R-METAL:3Kohm,1%,1/8W,AA,TP,1.8x3.2mm		VR112	2001-000666	R-CARBON:33OHM,5%,1/8W,AA,TP,1.8X3.2MM	
PR39	2004-000459	R-METAL:2.2Kohm,1%,1/8W,AA,TP,1.8x3.2m		VR113	2001-000666	R-CARBON:33OHM,5%,1/8W,AA,TP,1.8X3.2MM	
PR4	2001-000429	R-CARBON:1KOHM,5%,1/8W,AA,TP,1.8X3.2MM		VR114	2001-000666	R-CARBON:33OHM,5%,1/8W,AA,TP,1.8X3.2MM	
PR40	2003-000111	R-METAL OXIDE:0.47ohm,5%,1W,AD,TP,4.3x12		VR115	2001-000666	R-CARBON:33OHM,5%,1/8W,AA,TP,1.8X3.2MM	
PR5	2001-000281	R-CARBON:100OHM,5%,1/8W,AA,TP,1.8X3.2MM		VR116	2001-000666	R-CARBON:33OHM,5%,1/8W,AA,TP,1.8X3.2MM	
PR6	2001-000429	R-CARBON:1KOHM,5%,1/8W,AA,TP,1.8X3.2MM		VR117	2001-000969	R-CARBON:75OHM,5%,1/8W,AA,TP,1.8X3.2MM	
PT01	AH26-00008A	TRANS-SWITCHING:-,85V-240V,UL/CSA,EE2821	△	VR12	2001-000591	R-CARBON:3.3KOHM,5%,1/8W,AA,TP,1.8X3.2MM	
PVA01	1405-000186	VARISTOR:470V,4500A,17x12mm,TP		VR13	2001-000591	R-CARBON:3.3KOHM,5%,1/8W,AA,TP,1.8X3.2MM	
PZD31	0403-000716	DIODE-ZENER:MTZJ4.7B,4.7V,4.55-4.8V,500m		VR130	2001-000969	R-CARBON:75OHM,5%,1/8W,AA,TP,1.8X3.2MM	
RC12	2201-000812	C-CERAMIC,DISC:2.2nf,20%,400V,Y5U,BK,11x	△	VR132	2001-000780	R-CARBON:470OHM,5%,1/8W,AA,TP,1.8X3.2MM	
RC13	2201-000812	C-CERAMIC,DISC:2.2nf,20%,400V,Y5U,BK,11x	△	VR133	2001-000780	R-CARBON:470OHM,5%,1/8W,AA,TP,1.8X3.2MM	
RL03	3301-000297	CORE-FERRITE BEAD:AA,3.6x1.2x5.7mm,1400,		VR14	2001-000591	R-CARBON:3.3KOHM,5%,1/8W,AA,TP,1.8X3.2MM	
SVJ1	3722-001375	JACK-DIN:4P,-,NI,BLK,-		VR146	2001-000969	R-CARBON:75OHM,5%,1/8W,AA,TP,1.8X3.2MM	

Electrical Parts List

Loc.No	Part No	Description ; Specification	Remark
VR15	2001-000734	R-CARBON:4.7KOHM,5%,1/8W,AA,TP,1.8X3.2MM	
VR16	2001-000734	R-CARBON:4.7KOHM,5%,1/8W,AA,TP,1.8X3.2MM	
VR17	2001-000666	R-CARBON:330HM,5%,1/8W,AA,TP,1.8X3.2MM	
VR175	2001-000969	R-CARBON:750HM,5%,1/8W,AA,TP,1.8X3.2MM	
VR176	2001-000554	R-CARBON:2700HM,5%,1/8W,AA,TP,1.8X3.2MM	
VR177	2001-000780	R-CARBON:4700HM,5%,1/8W,AA,TP,1.8X3.2MM	
VR178	2001-000003	R-CARBON:3300HM,5%,1/8W,AA,TP,1.8X3.2MM	
VR18	2001-000666	R-CARBON:330HM,5%,1/8W,AA,TP,1.8X3.2MM	
VR192	2001-000969	R-CARBON:750HM,5%,1/8W,AA,TP,1.8X3.2MM	
VR4	2001-000221	R-CARBON:1.2KOHM,5%,1/8W,AA,TP,1.8X3.2MM	
VR5	2001-000221	R-CARBON:1.2KOHM,5%,1/8W,AA,TP,1.8X3.2MM	
VR7	2001-000977	R-CARBON:8.2KOHM,5%,1/8W,AA,TP,1.8X3.2MM	
VR8	2001-000977	R-CARBON:8.2KOHM,5%,1/8W,AA,TP,1.8X3.2MM	
VR9	2001-000008	R-CARBON:15KOHM,5%,1/8W,AA,TP,1.8X3.2MM	

701 ASSY-PCB-POWER

CON24	AH39-00033A	LEAD CONNECTOR-ASSY,-,51004-04,35023-04,	
KD2	0601-001238	LED:ROUND,RED,3.1mm,697nm	
KSW2	3404-000165	SWITCH-TACT;12V,50mA,160gf+-50gf,6x6mm,S	

702 ASSY-PCB-PLAY

CON22	AH39-00028A	LEAD CONNECTOR-ASSY,-,51004-06,35023-06,	
FSW1	3404-000165	SWITCH-TACT;12V,50mA,160gf+-50gf,6x6mm,S	
FSW2	3404-000165	SWITCH-TACT;12V,50mA,160gf+-50gf,6x6mm,S	
FSW4	3404-000165	SWITCH-TACT;12V,50mA,160gf+-50gf,6x6mm,S	
FSW5	3404-000165	SWITCH-TACT;12V,50mA,160gf+-50gf,6x6mm,S	
FSW6	3404-000165	SWITCH-TACT;12V,50mA,160gf+-50gf,6x6mm,S	

202 ASSY-PCB-DECK;DP-3,-

CN1	3708-001081	CONNECTOR-FPC/FC/PIC;11P,1mm,STRAIGHT,SN	
CN2	3708-001001	CONNECTOR-FPC/FC/PIC;20P,1mm,SMD-A,SN	
CN3	3711-000827	CONNECTOR-HEADER:BOX,2P,1R,2mm,STRAIGHT,	
CN4	3708-001108	CONNECTOR-FPC/FC/PIC;8P,1.0MM,ANGLE,SN	
CN5	3708-001084	CONNECTOR-FPC/FC/PIC;40P,1.25mm,ANGLE,SN	
DC1	2203-000208	C-CERAMIC,CHIP:100nF,10%,50V,X7R,TP,3216	
DC2	2203-000208	C-CERAMIC,CHIP:100nF,10%,50V,X7R,TP,3216	
DC3	2203-000208	C-CERAMIC,CHIP:100nF,10%,50V,X7R,TP,3216	
DC4	2203-000612	C-CERAMIC,CHIP:22nF,10%,50V,X7R,TP,3216,	
DE1	2404-000259	C-TA,CHIP:47uF,20%,6.3V,-,TP,6032,-	
DE2	2404-000259	C-TA,CHIP:47uF,20%,6.3V,-,TP,6032,-	
DL1	3301-000325	CORE-FERRITE BEAD:AB,3.2x2.5x1.3mm,-,-	
DLED	0601-001372	LED:ROUND,GRN,3.5MM,621NM	
DR1	2007-000800	R-CHIP:360ohm,5%,1/8W,DA,TP,3216	
DR2	2007-000451	R-CHIP:1800HM,5%,1/8W,DA,TP,3216	
DR3	2007-000451	R-CHIP:1800HM,5%,1/8W,DA,TP,3216	
DR4	2007-000303	R-CHIP:10KOHM,5%,1/8W,DA,TP,3216	
DR5	2007-000303	R-CHIP:10KOHM,5%,1/8W,DA,TP,3216	
SW1	AH34-30001A	SWITCH-PUSH:2EA,6.65X7.5,-,DC5V	
SW2	3403-001001	SWITCH-PUSH:5V,5mA,-,OFF-ON	
SW3	3408-000323	SWITCH-SLIDE,S5SS712GD011/12VDC 100ma	

Loc.No	Part No	Description ; Specification	Remark
--------	---------	-----------------------------	--------

10. Block Diagram

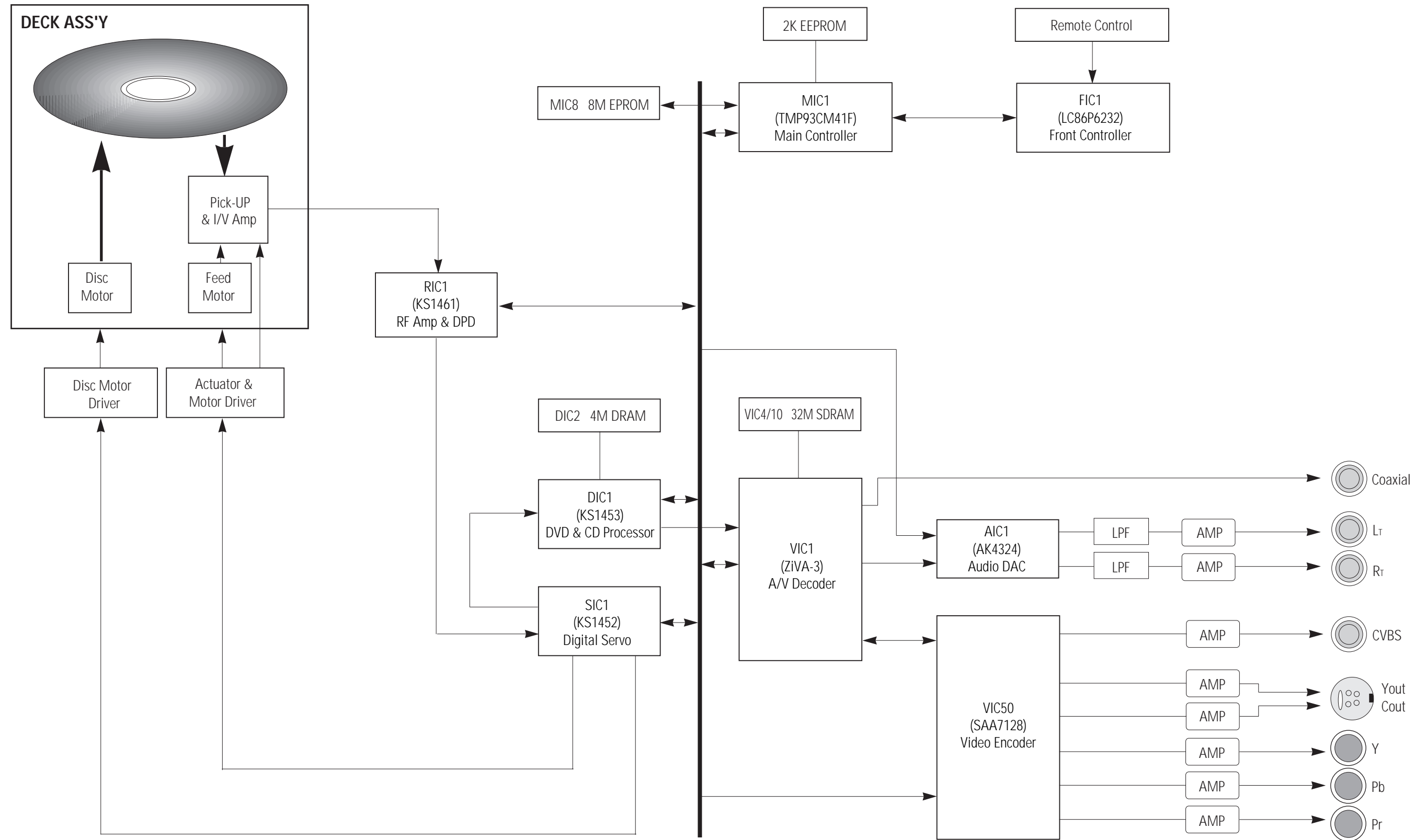

MEMO

11. PCB Diagrams

11-1 Main	11-2
11-2 Jack	11-3
11-3 Power	11-4
11-4 Play	11-4
11-5 Deck	11-4

11-1 Main

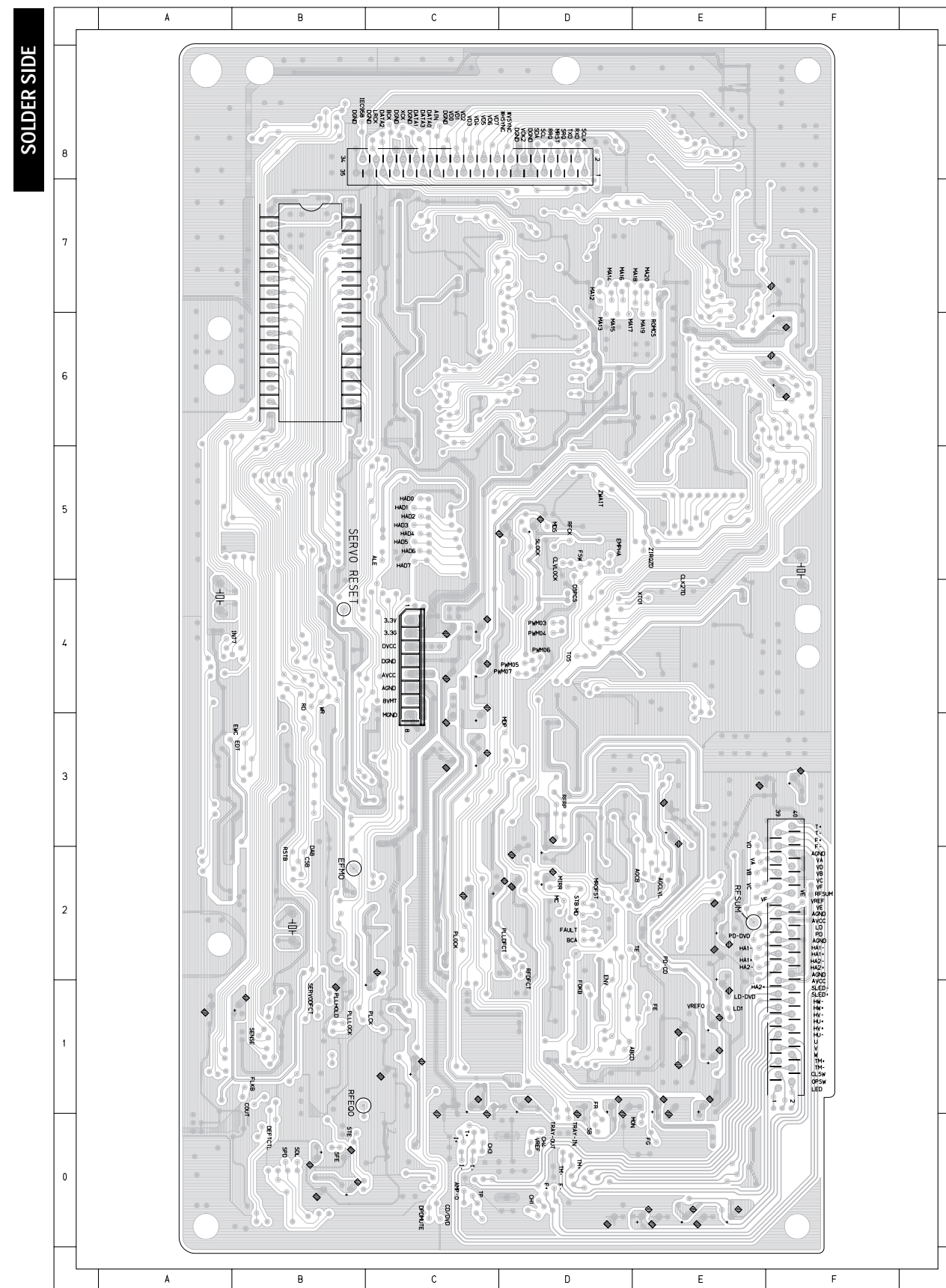
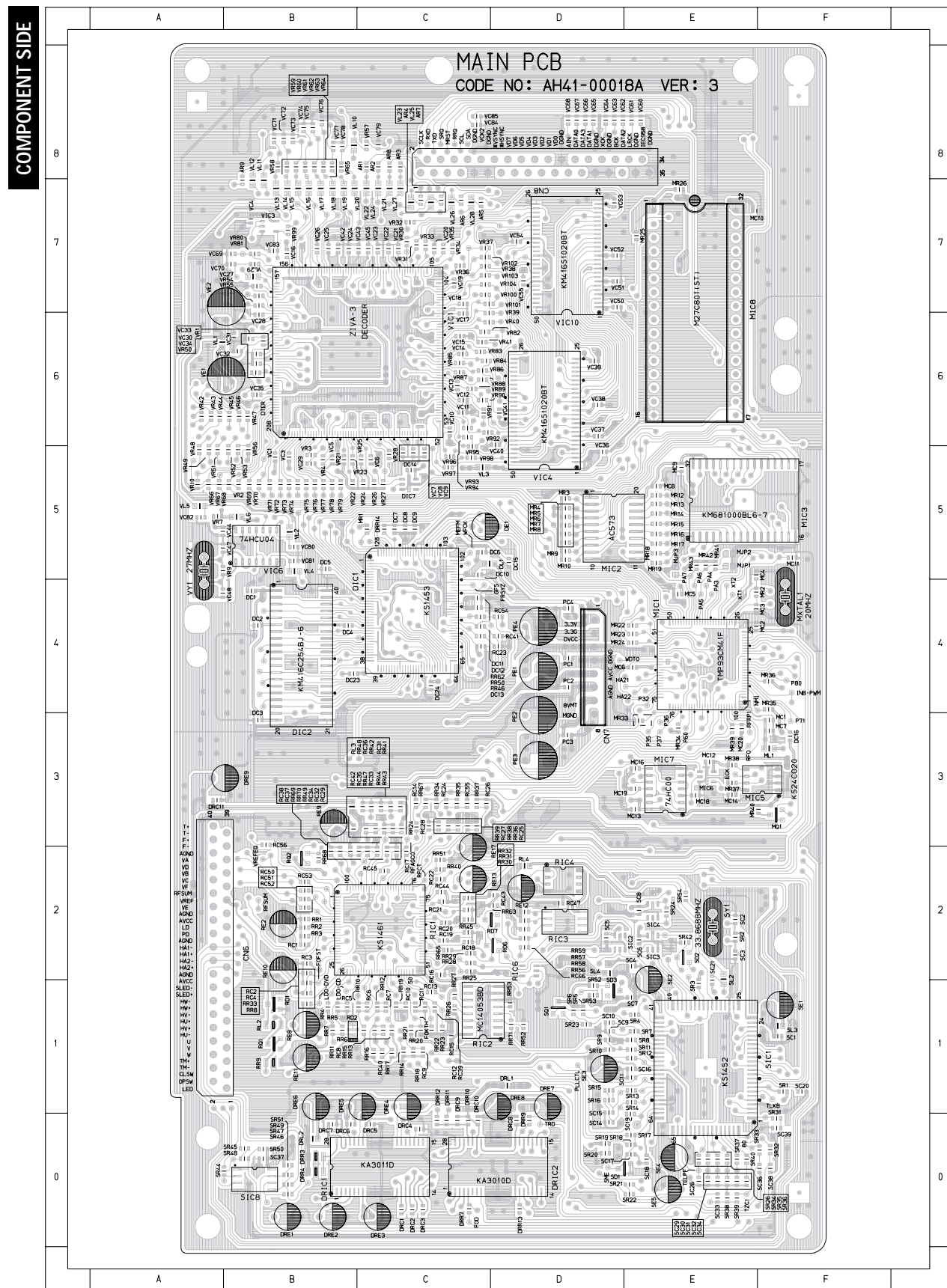

11-2 Jack

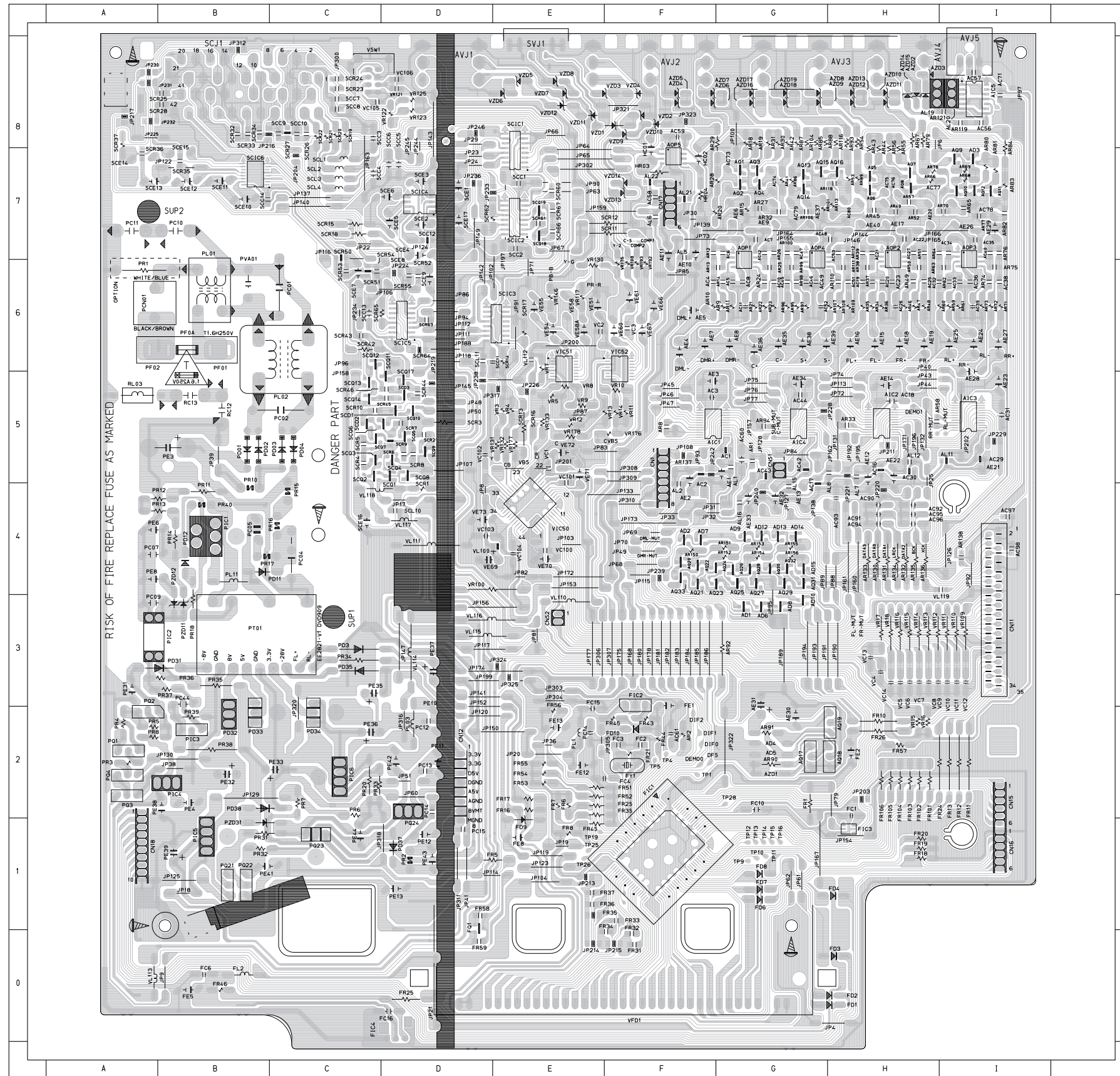

11-3 Power

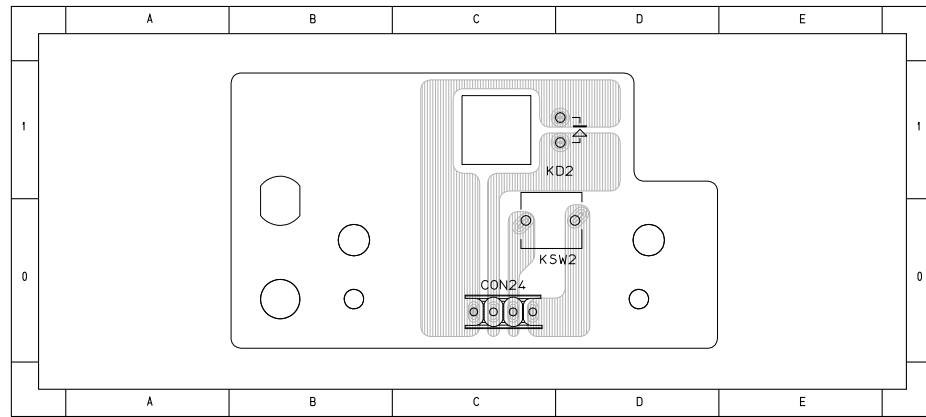

11-4 Play

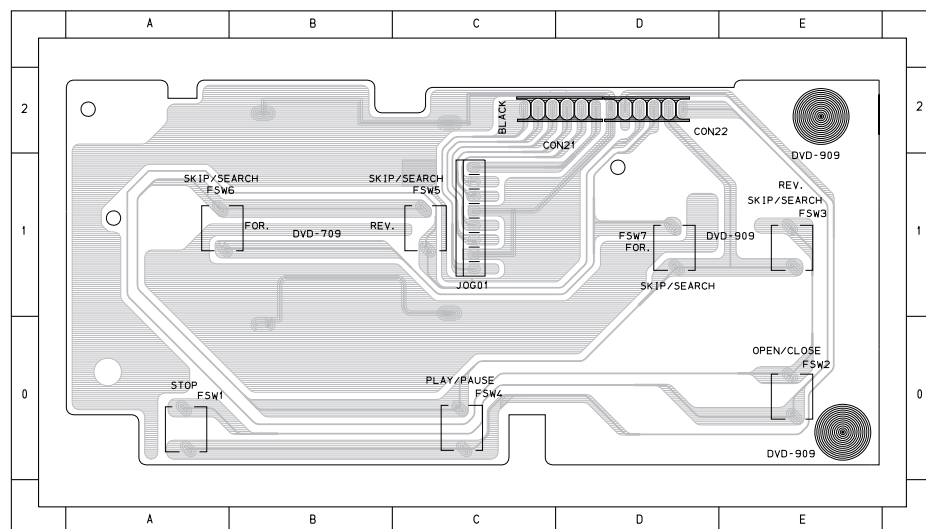

11-5 Deck

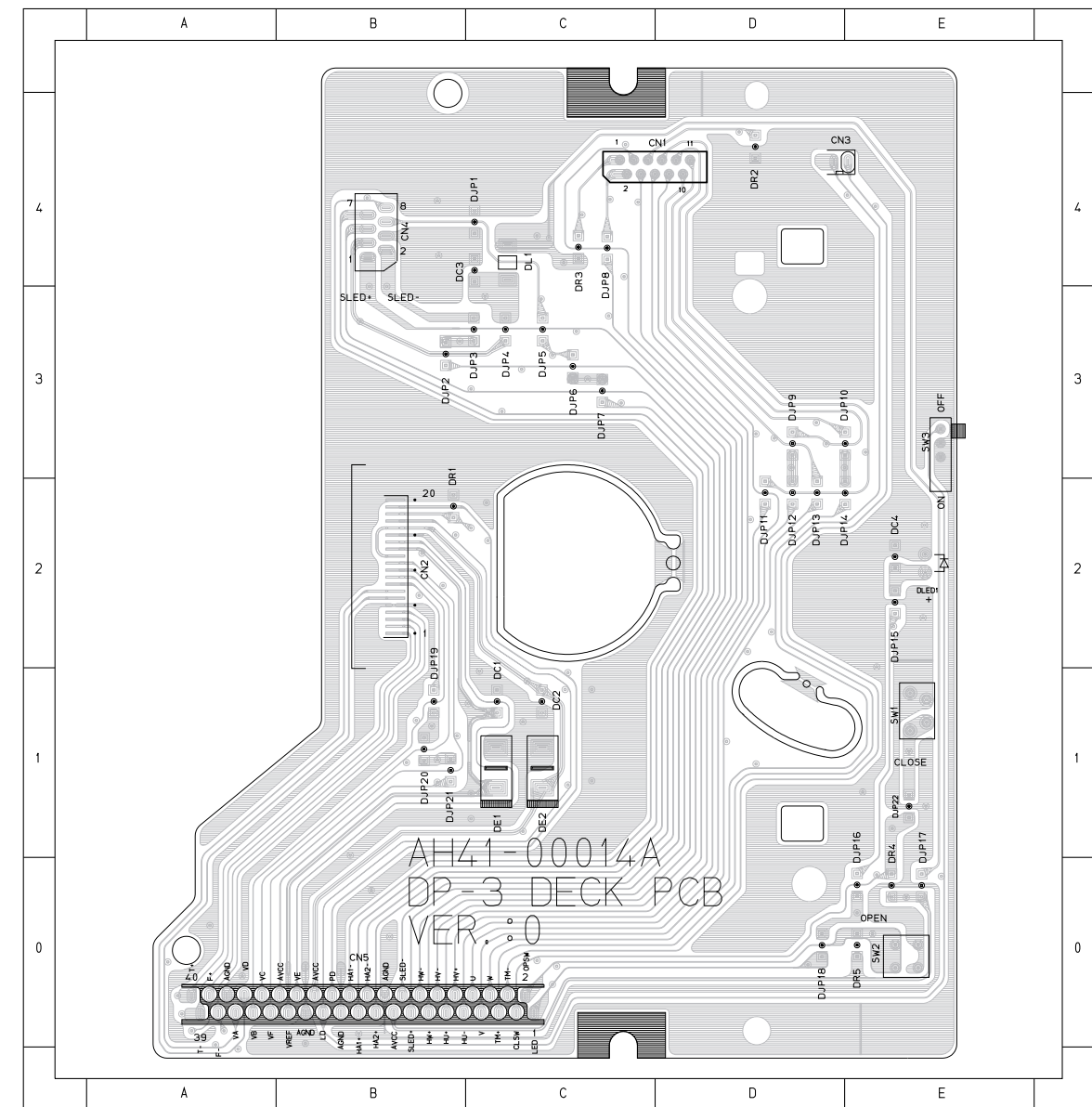

12. Wiring Diagram

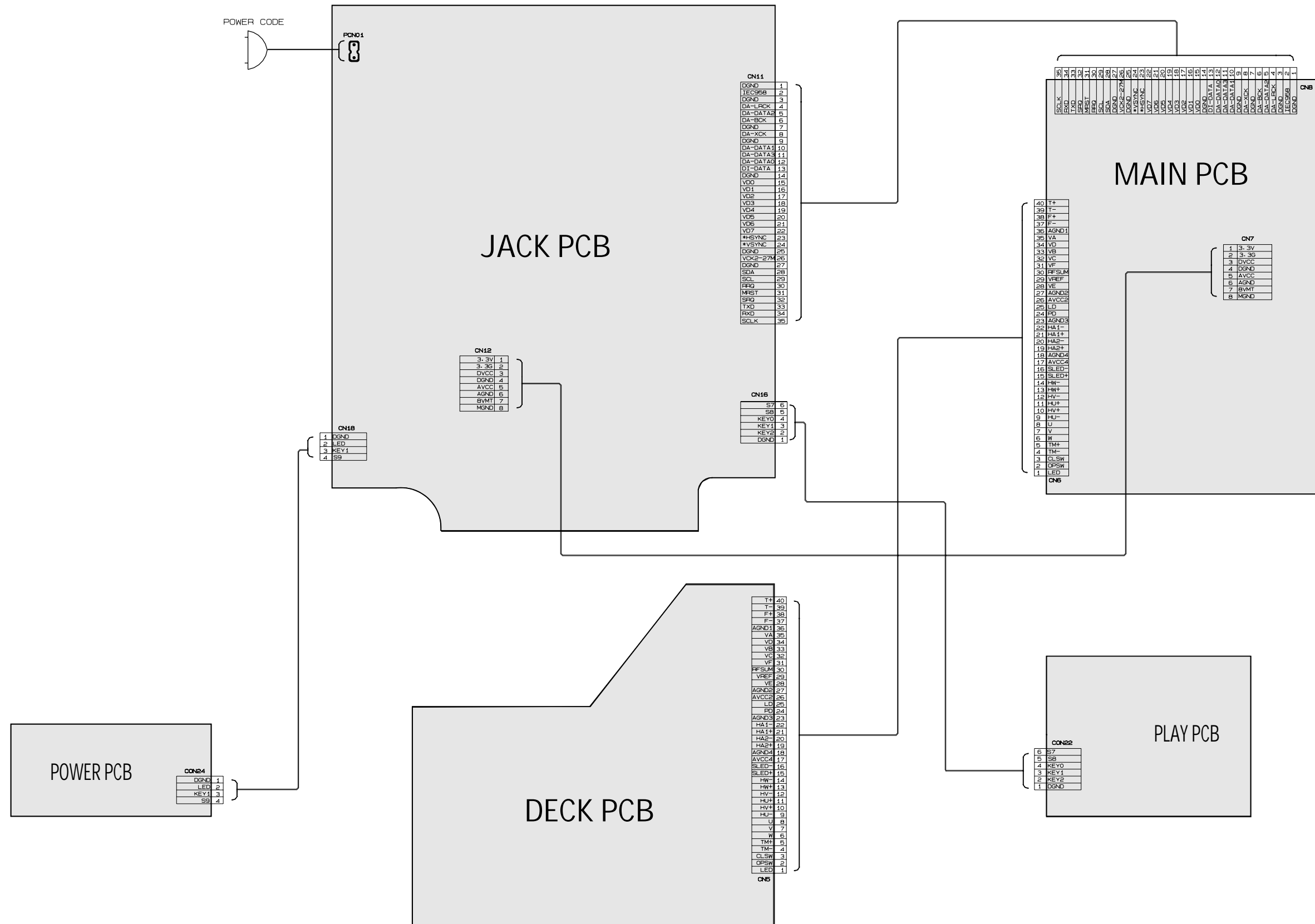

MEMO